

Mr J. S. Ayall 2020

ELECTRICAL COMMUNICATION

*Technical Journal of the
International Telephone and Telegraph Corporation
and Associate Companies*

OPERATING PRINCIPLES OF THE 7-A2 ROTARY SYSTEM

ROTARY EQUIPMENT OF THE HAGUE DISTRICT

9-A-1 SINGLE-CHANNEL CARRIER TELEPHONE SYSTEM

PRE-HEATING BY HIGH-FREQUENCY CURRENTS

CATHODE-EXCITED LINEAR AMPLIFIERS

RADAR VACUUM-TUBE DEVELOPMENTS

GENERAL PRINCIPLES OF VALVE-CRATE DESIGN

SPIRAL DELAY LINES

EQUATIONS FOR GENERALIZED TRANSMISSION LINES

SPECIAL ASPECTS OF BALANCED SHIELDED LOOPS

ELECTRICAL COMMUNICATION: 1940-1945, PART III

RECENT TELECOMMUNICATION DEVELOPMENTS

SEPTEMBER, 1946

VOL. 23

No. 3



ELECTRICAL COMMUNICATION

Technical Journal of the
INTERNATIONAL TELEPHONE AND TELEGRAPH CORPORATION
and Associate Companies

H. T. KOHLHAAS, Editor

F. J. MANN, Managing Editor

H. P. WESTMAN, Associate Editor

REGIONAL EDITORS

E. G. PORTS, Federal Telephone & Radio Corporation, Newark, New Jersey
B. C. HOLDING, Standard Telephones & Cables, Ltd., London, England
S. VAN MIERLO, Laboratoire Central de Télécommunications, Paris, France

EDITORIAL BOARD

H. Busignies H. H. Buttner G. Deakin E. M. Deloraine W. T. Gibson
Sir Frank Gill W. Hatton E. Labin E. S. McLarn A. W. Montgomery Haraden Pratt
G. Rabuteau F. X. Rettenmeyer T. R. Scott C. E. Strong E. N. Wendell W. K. Weston

Published Quarterly by the

INTERNATIONAL TELEPHONE AND TELEGRAPH CORPORATION

67 BROAD STREET, NEW YORK 4, N.Y., U.S.A.

Sosthenes Behn, President

Charles D. Hillis, Jr., Vice President and Secretary

Subscription, \$1.50 per year; single copies, 50 cents

Copyrighted 1946 by International Telephone and Telegraph Corporation

Volume 23

September, 1946

Number 3

CONTENTS

	PAGE
OPERATING PRINCIPLES OF THE 7-A2 ROTARY SYSTEM	249
<i>By William Hatton</i>	
ROTARY EQUIPMENT OF THE HAGUE DISTRICT	265
<i>By D. A. Alberts and J. P. Verlooy</i>	
9-A-1 SINGLE-CHANNEL CARRIER TELEPHONE SYSTEM	278
<i>By W. A. Brandt, R. G. Maddox, and A. C. Phillips</i>	
PRE-HEATING BY HIGH-FREQUENCY CURRENTS	291
<i>By A. J. Maddock</i>	
CATHODE-EXCITED LINEAR AMPLIFIERS	297
<i>By J. J. Muller</i>	
RADAR VACUUM-TUBE DEVELOPMENTS	306
<i>By J. J. Glauber</i>	
GENERAL PRINCIPLES OF VALVE-CRATE DESIGN	320
<i>By R. A. L. Cole</i>	
SPIRAL DELAY LINES	327
<i>By K. H. Zimmermann</i>	
EQUATIONS FOR GENERALIZED TRANSMISSION LINES	329
<i>By Sidney Frankel</i>	
SPECIAL ASPECTS OF BALANCED SHIELDED LOOPS	332
<i>By L. L. Libby</i>	
ELECTRICAL COMMUNICATION: 1940-1945, PART III	339
RECENT TELECOMMUNICATION DEVELOPMENTS	366
CONTRIBUTORS TO THIS ISSUE	371





After six years of enforced secrecy the International Marine Radio Company (London) is privileged to announce the peacetime inauguration of its extensive "Queen Elizabeth" radio installation. The capabilities of this installation were amply demonstrated during the war years

Operating Principles of the 7-A2 Rotary System*

By WILLIAM HATTON

Deputy Chief Engineer, International Telephone & Telegraph Corporation, New York, New York

WHILE now-a-days, conversion from manual to automatic operation is regarded as commonplace, the introduction of the rotary system to the telephone public of the U. S. A. is an event of some importance. The I.T. & T. Rotary System, used extensively in other parts of the world, is now being manufactured in the U. S. A. and will be first installed in Rochester, New York, and Lexington, Kentucky. This paper describes the equipment and operation of a typical 10 000-line unit of the 7-A2 rotary type.

. . .

The American Standard definition of a dial telephone system¹ is as follows:

A dial telephone system is a telephone system in which telephone connections between customers are ordinarily established by electric and mechanical apparatus controlled by manipulations of dials operated by the calling parties.

The phrase "electric and mechanical apparatus" should be emphasized because it is this combination of electrical and mechanical design that makes the present telephone art so interesting. The form of mechanical structure and the choice of suitable materials are to a large extent governed by the electric-circuit requirements and, conversely, the electric circuits must suit the mechanical design of the switches.

To produce a system which fulfills the many complex circuit requirements of today, and is at the same time sound and robust mechanically, requires the closest co-operation between circuit and mechanical designers.

The American Standard definition of the rotary system² is as follows:

A rotary dial system is a type of dial telephone in which the switching apparatus is generally characterized by the following features:

1. The brushes of the selecting mechanisms are moved in a circular arc by a rotating member.
2. The selecting mechanisms are driven by power apparatus.
3. The dial pulses are received and stored by controlling mechanisms which govern the subsequent operations necessary in establishing a telephone connection.

The first two of these features can be better understood perhaps in relation to other systems. For example, in the step-by-step system, the wipers of the selecting mechanisms are moved both vertically and in horizontal circular arcs. In the panel system, the wipers are raised and lowered in a vertical direction.

The third definition refers to dial pulses received and stored by controlling mechanisms. When the dial rotates it opens an otherwise closed circuit a given number of times depending on the digit dialed and causes a relay at the exchange to release at each interruption and re-operate at each closure of the circuit. At normal dial speed, 10 of these pulses are transmitted per second, 100 milliseconds per pulse, the opening being 66 milliseconds and the closure 34 milliseconds.

During the period between digits, the line circuit usually remains closed a minimum of 350 milliseconds. This relatively long period without interruption indicates completion of dialing of the digit, and the equipment at the exchange is thereby prepared to receive the next digit.

While all automatic telephone systems use this method of transmitting the directory number of the called subscriber, there are a number of different types of exchange equipment. The principal systems in operation today fall into one of the following three classifications: step-by-step, power drive, and all relay, the latter including the Bell cross-bar system.

The term "step-by-step" is almost self-explanatory. The switch movement is made in a series of distinct steps, one for each interruption sent by the dial; thus, if digit 9 is dialed, 9 interruptions of the line circuit cause 9 operations of the control magnet of the switch and 9 operations

* Presented before Rochester Engineering Society, Rochester, New York, on April 4, 1946.

¹ "American Standard Definitions of Electrical Terms, C42-1941," American Standards Association, New York, N. Y., p. 224.

² P. 225 of reference 1.

of the pawl-and-ratchet drive, moving the switch 9 steps or terminals.

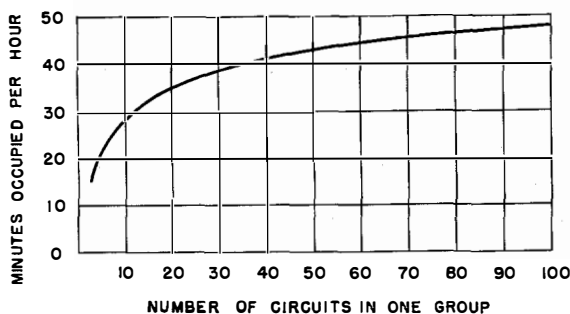

Fig. 1—The number of minutes out of an hour during which a switching trunk will be occupied depends on how many circuits are in the group that it may reach through the selector switch. The above curve is based on Poisson's formula and allows for a delay of only one call out of each 100 placed.

In contrast, the switches of power-driven systems are driven from the position of rest to the required terminal with a smooth continuous movement requiring only one operation of the control magnet. It follows that power-driven switches cannot respond directly to the dial pulses; some device is required to stand between the dial and the selector switches. This device is known as a sender, and receives the pulses from the dial representing the directory number of the called subscriber, and in accordance with them,

controls the movement of the selectors required to establish the connection. During their rotation, the power-driven switches create pulses termed "revertive pulses" which are received and recorded in the sender and determine the movement of the selector switch in accordance with the number dialed.

The introduction of the sender opened a new field of development and made possible the design of switching mechanisms not limited by decimal numbering and direct response to the dial pulses.

Without a sender, there are definite limitations on the capacity of the selector switch. It cannot have more than 10 levels and moreover must find and connect to a free circuit on the selected level during the interval between digits, thereby imposing a definite limitation on the number of circuits per level.

The use of a sender leaves the designer free to concentrate on the most economical capacity of a switch and to make full use of power drive to obtain a robust form of mechanical structure with adequate contact pressure, minimum vibration, and long life.

The number of outlets or circuits per level is an important factor in the cost of a complete system and affects the number of interoffice circuits as well as the number of selectors in an office.

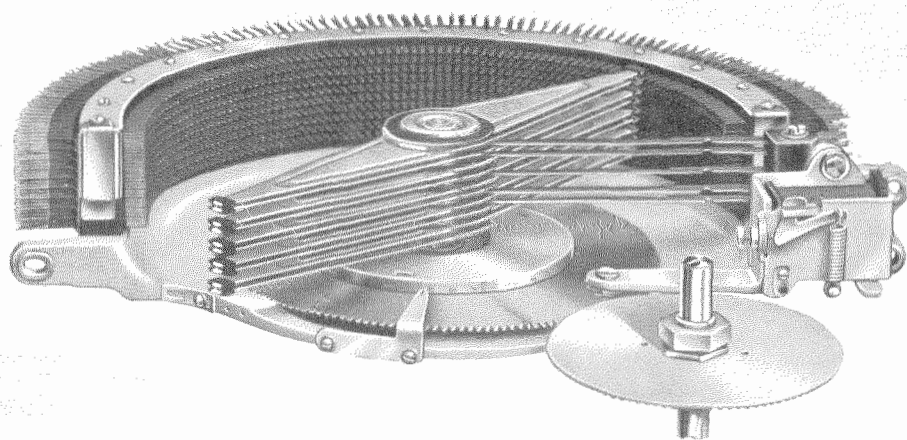

Fig. 2—Complete finder switch with drive. The signal to start the switch may come from any one of the circuits connected to the 200 terminals. The brushes move over the terminal banks until the calling terminal is reached and the signal thereon stops the rotation of the brushes. Rotation is in a single direction and one end of the double-ended brushes makes contact when the other end leaves the bank.

Applying the theories of such eminent mathematicians as Poisson and Erlang, it can be shown that within certain limitations the number of connections which can be carried by a circuit increases as the size of the group increases.

From the curve of Fig. 1, it will be seen that a circuit in a group of 10 is occupied for 29 minutes out of one hour. In a group of 20 the occupancy is 36 minutes, and in a group of 30 the occupancy is 39 minutes. These results are based on the condition that all circuits of the group are available to the hunting selector.

To improve the efficiency of circuits connected to selectors with levels of only 10 terminals, a group of, say 30 circuits, is spread over 60 or 80 selectors. Some of the circuits are made individual to a group of 10 selectors and others are common to all 60 or 80 selectors. This is known as a "graded multiple," and is generally considered to increase the circuit efficiency by approximately 15 percent.

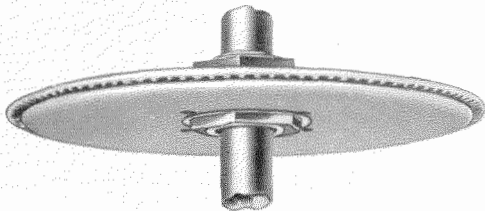

Fig. 3—Drive assembly of finder switch.

The rotary selectors have a capacity of 30 circuits per level and 10 levels, making 300 circuits in total.

1 Rotary Automatic

The rotary system uses finder switches, selectors, sequence switches, and the well-known flat-type relay. These pieces of apparatus are built into different layouts of telephone equipment: large exchanges with heavy traffic operating in multioffice networks, unattended small-town and rural exchanges, private branch exchanges, and full-automatic long-distance exchanges.

1.1 FINDER SWITCH

Referring again to the "American Standard Definitions of Electrical Terms," a finder switch³ is defined as follows:

A finder switch is a switching mechanism, associated with a circuit, designed to move over a number of terminals to which are connected circuits, over any one of which a signal to start the switch may be transmitted, in order to find the specific circuit from which the starting signal has come and connect it to the circuit associated with this finder switch.

In the rotary system the number of terminals per finder switch is 200, and for average traffic 22 finder switches are provided for each group of 200 lines. The function of the switch is to find and connect to any one of the 200 lines in the calling condition.

³ P. 227 of reference 1.

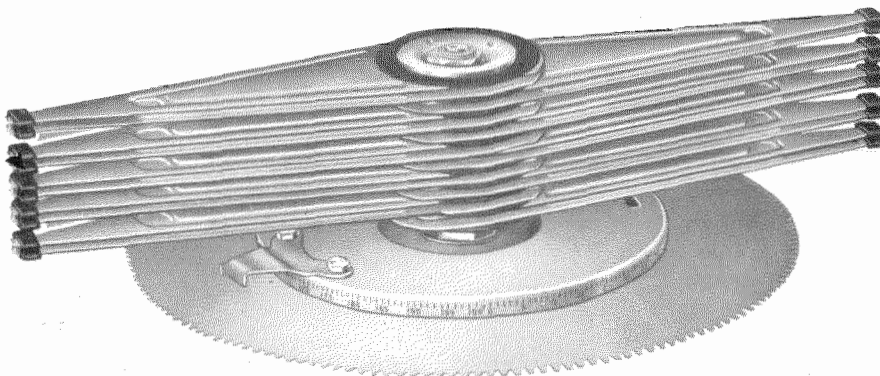

Fig. 4—Brush-carriage assembly of finder switch.

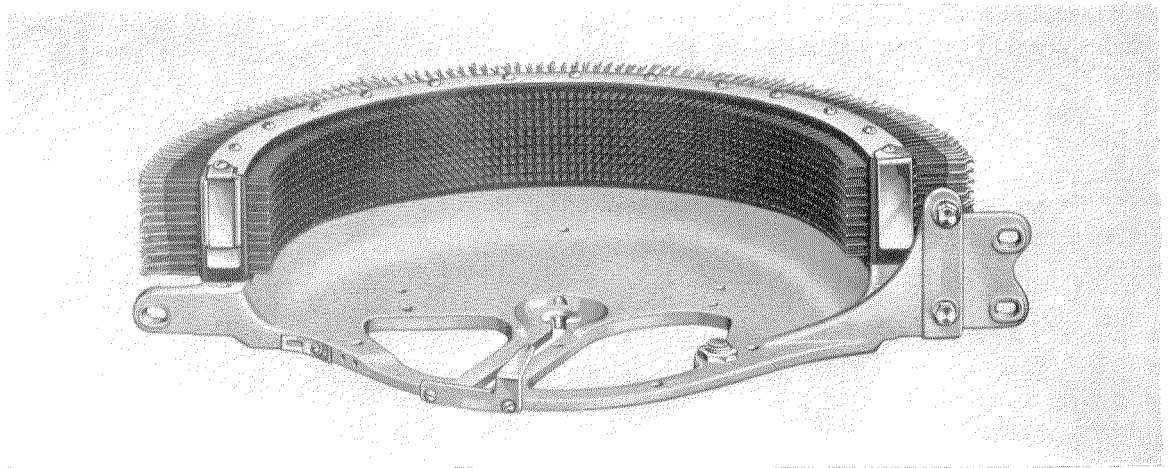

Fig. 5—Finder-switch terminal arc assembly.

The switch, shown in Fig. 2, comprises a bank of terminals, a number of brushes which sweep over these terminals, and means to drive these brushes and stop them on the terminals of the calling line.

The driving mechanism consists of two flat gears punched out of sheet nickel-silver. The driving gear is mounted on a continuously rotating vertical shaft and the driven gear is mounted on the center shaft of the finder which also carries the wipers or brushes. The driven gear is flexible and normally is held out of mesh with the driving gear by downward pressure from a powerful helical spring on the control magnet. To drive the finder, electric current is sent through the control magnet and the attraction of the armature removes the pressure from the driven gear which then springs upward and engages with the driving gear.

This method of transmitting power to drive the switch brushes is an interesting and characteristic feature of the rotary system, and the same principle is used to drive selectors and sequence switches. Life tests on these flexible gears show that after 18 million revolutions the end of their useful life is not even approached.

The control magnet is of single-coil design with a relatively high-resistance winding of 175 ohms. This makes the magnet self-protecting, i.e., it can remain energized indefinitely without getting too hot and creating thereby the risk of fire.

The brushes are stamped out of sheet nickel-silver and are provided with phosphor-bronze contact tips. Also, removable fiber shoes are

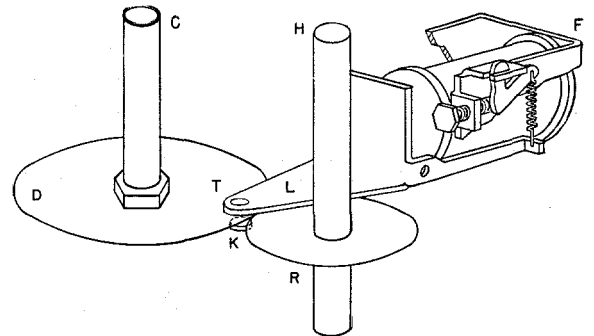

Fig. 6—Finder-switch driving mechanism.

slipped over the ends of the brushes to facilitate smooth rotation over the banks of terminals.

The frame is of die-cast aluminum alloy provided with 3 lugs for fixing the finder to the bay. The rotor or brush member is fastened to the center of this frame by a steel pivot. Connection to the rotating wipers is made by feeder brushes held in molded bakelite and fastened to the frame by a single steel bolt.

The principal components of the finder switch are shown in Figs. 3, 4, and 5. Fig. 6 indicates the method of operation. Closure of the control-magnet circuit causes the attraction of armature *L*. Flexible gear *D*, normally held pressed against its back stop *K* by armature *L*, is released under its own tension and automatically meshes with the driving gear *R* mounted on the common bay shaft *H* which is in continuous rotation. The rotor, mounted on shaft *C*, thus rotates on the steel pivot fastened to the switch frame.

When the brushes reach the terminals of the calling line, a test relay operates and opens the circuit of the control magnet. This releases armature *L* which instantly deflects the flexible gear *D* out of mesh with driving gear *R* and presses it against the back stop *K*. In this position the armature stud *T* acts as a positive brake on the gear *D* and holds it rigidly in position during the time that the switch is not rotating.

The finder is designed to rotate at a speed of 45 terminals per second. While this is a comparatively high speed, ample margin is available to stop the rotor securely on the proper arc terminal under the most unfavorable conditions of circuit, motor speed, and battery voltage. The contact pressure specified for the brushes is 35 grams.

1.2 SELECTORS

We have seen that the function of the finder is to pick out from a group of 200, *any* line which may be in the calling condition. If two or more

lines are calling in the same group the brushes will stop on the first one to be reached.

The function of the selector, however, is to pick out *one particular* line, the one desired by the calling subscriber and determined by the directory number dialed. Except in very small exchanges, this cannot be accomplished by one selector, and in a 4-digit numbering scheme, 3 selectors in series are required; the first selecting the thousands digit, the second the hundreds, and the last selecting the tens and the units. The first and second selectors have two functions: to select and to hunt. They select the required group and then hunt to find an idle circuit in this group. The last selector also has two functions. It selects the required group of 10, but instead of hunting to find an idle circuit, it selects a given circuit in accordance with the units digit.

The "American Standard Definitions of Electrical Terms" defines a selector switch⁴ as follows:

⁴ P. 227 of reference 1.

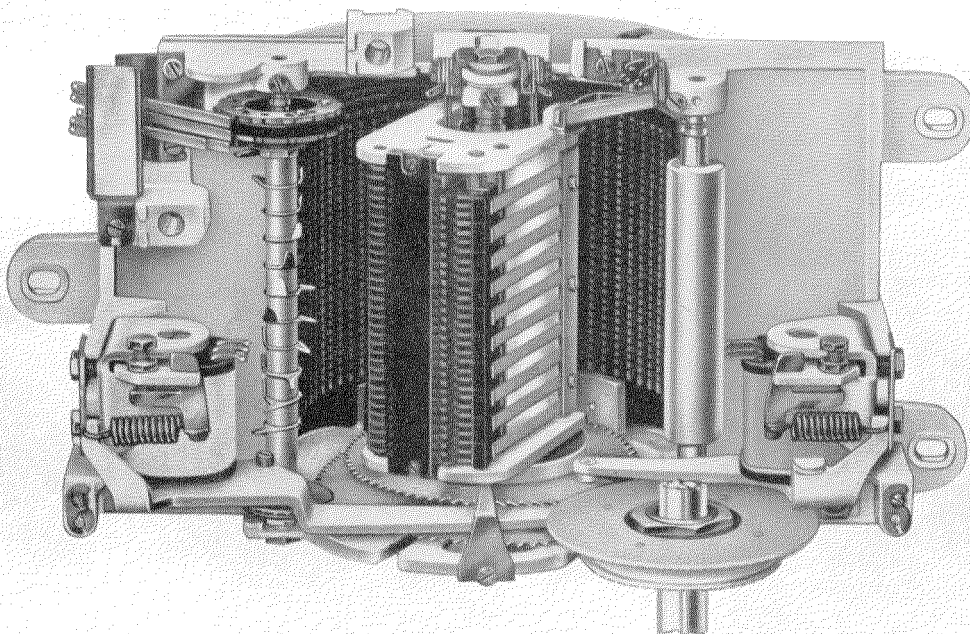

Fig. 7—Group selector consisting of 10 circuit levels each comprising 3 rows of terminals. A group of 3 contacts on one level of the rotating brush assembly may be tripped to make contact with the desired terminals.

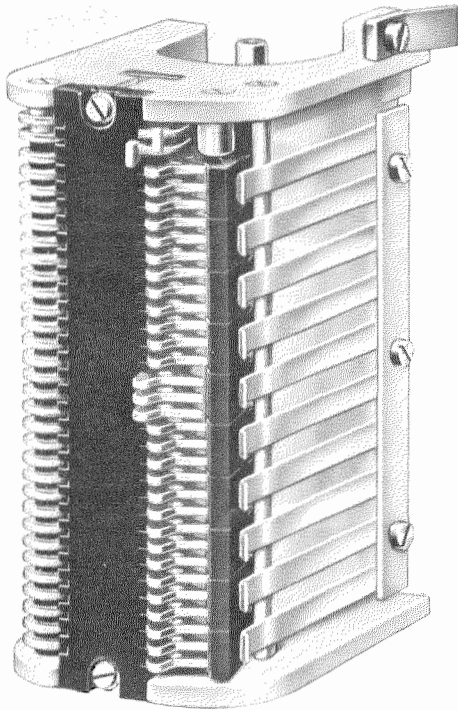

Fig. 8—Brush-carriage assembly of group selector.

A selector is a switch mechanism, associated with a circuit, designed to move over a number of terminals to which are connected groups of circuits in order to select a particular group of circuits in accordance with signals received over the circuit associated with this selector, and then to choose from the group an idle circuit and connect to it the circuit associated with this selector.

The definition expresses the dual function of a selector, namely, to select a particular group of circuits and then to choose an idle circuit from this group.

The circuits leading to the following selecting stage are represented by terminals which are grouped together to form a semicircular bank and arranged in 10 levels.

The rotary level-selecting mechanism is known as a trip spindle and the wipers or brushes are mounted in a die-cast frame known as a brush carriage which rotates in a clockwise direction and carries the brushes over the bank terminals. The 10 sets of brushes provided are positioned so that normally they do not make contact with

the bank terminals during rotation of the brush carriage.

Any one set of brushes can be tripped or unlatched so that during rotation of the brush carriage this set will make contact with the bank terminals. The trip spindle has ten sets of fingers and when positioned under control of the sender will cause a set of brushes to be unlatched corresponding with the level or group of lines in which the calling subscriber's number is found.

The trip spindle and the brush carriage are driven by flexible gears and the driving power is derived from a common electric motor which drives a vertical shaft on which the driving gears are mounted. The principal components of the selector are shown in Figs. 8, 9, 10, and 11.

The bank gives access to 300 circuits and is made of 3 terminal blocks each having 100 circuits. Each circuit requires 3 terminals and therefore each block has 300 terminals and the complete bank 900 terminals. Hard phosphor-bronze strips are used to form the terminals which are manufactured by slotting these strips in the form of a comb. Ten strips are molded into a

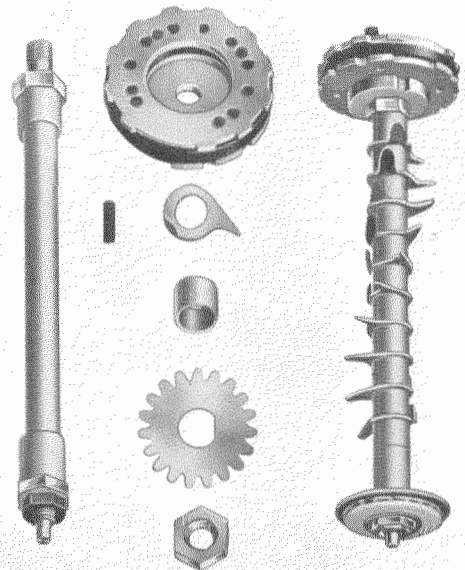

Fig. 9—Trip spindle which controls the level at which the contacts of the brush assembly are unlatched to make contact with the terminal bank of the group selector.

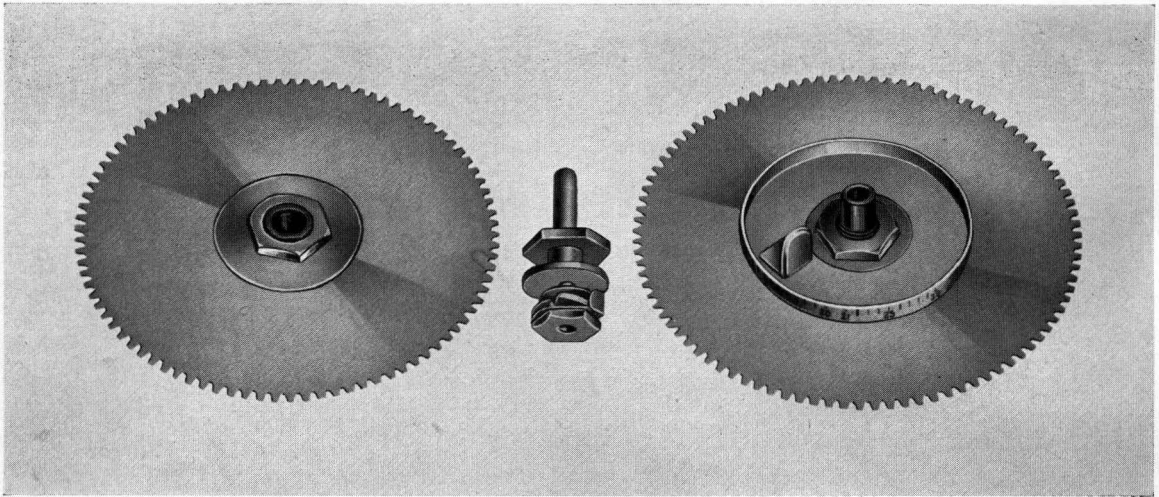

Fig. 10—The flexible-gear assembly is mounted on the brush carriage and is meshed with a driving gear to rotate the brush carriage.

single bakelite block. The block is then placed under a 29-blade saw and the inner face of the comb is cut, producing 30 terminals in each vertical column. A special form of silk-insulated ribbon cable is connected to the rear side of each terminal and serves to multiple the banks of a number of selectors.

The selector is provided with 2 control magnets, one of which controls the meshing and unmeshing of the trip-spindle driving gears, and the other performs the same function on the brush-carriage driving gears.

The trip spindle rotates in a clockwise direction and each 30 degrees of movement is known as a "step." The speed of rotation is 14 steps per second and each step brings into operation a level trip finger. A commutator, mounted on the top of the trip spindle, creates revertive pulses which are received and counted by the sender and control the number of steps which the trip spindle is required to make to determine the particular group of circuits.

When the trip spindle has completed its movement and a set of brushes is unlatched at the

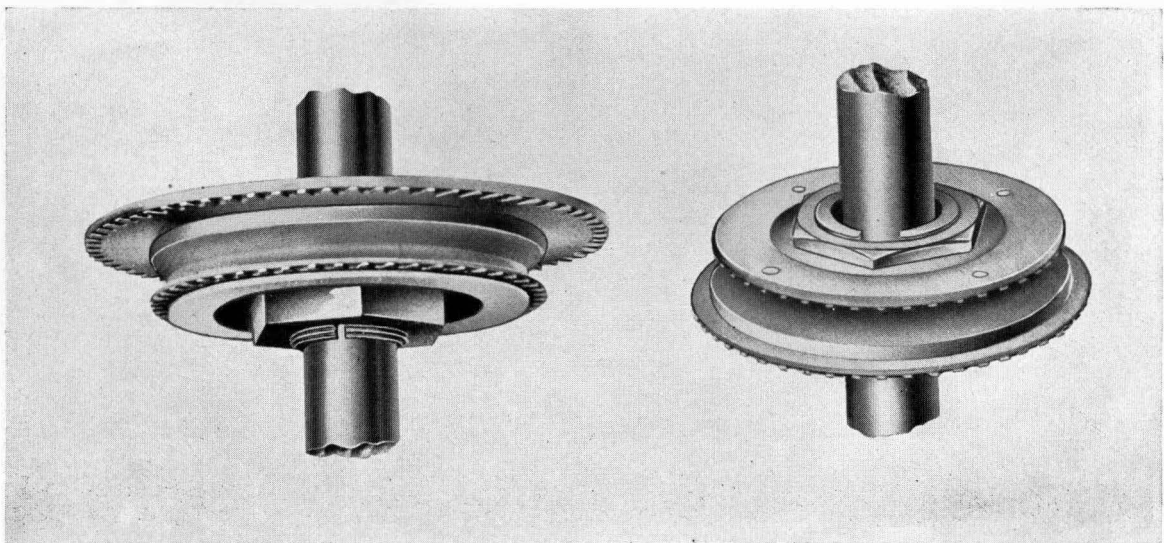

Fig. 11—Two driving gears are required for group selectors and final selectors. One gear drives the brush carriage and the other controls the position of the trip spindle.

required level, the brush carriage is rotated. The rotation of the brush carriage, the second function of the selector, is to find an idle circuit in the

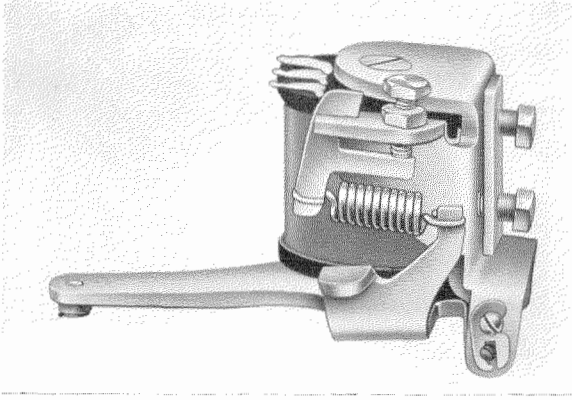

Fig. 12—There are 2 control magnets on both the group and final selectors. In the nonoperated condition, the long arm holds the flexible gear of the brush carriage or of the trip spindle out of mesh with the respective driving gears.

particular group. Selectors of this type are termed "group selectors."

Selectors of the last stage, the function of which is to select the tens and units and connect through to the called number, are termed "final selectors," but they are also known in other systems as connectors. They are slightly different from group selectors. The bank capacity is 200 circuits and the brush carriage is provided with a commutator to create revertive pulses. Each 5 degrees and 15 minutes movement is known as a "step" and each step corresponds to a vertical column of bank terminals. The final-selector brush carriage rotates at 14 steps per second whereas the group-selector brush carriage rotates at 28 steps per second.

1.3 SEQUENCE SWITCH

The sequence switch is a form of power-driver relay and is used in all the principal circuits. It

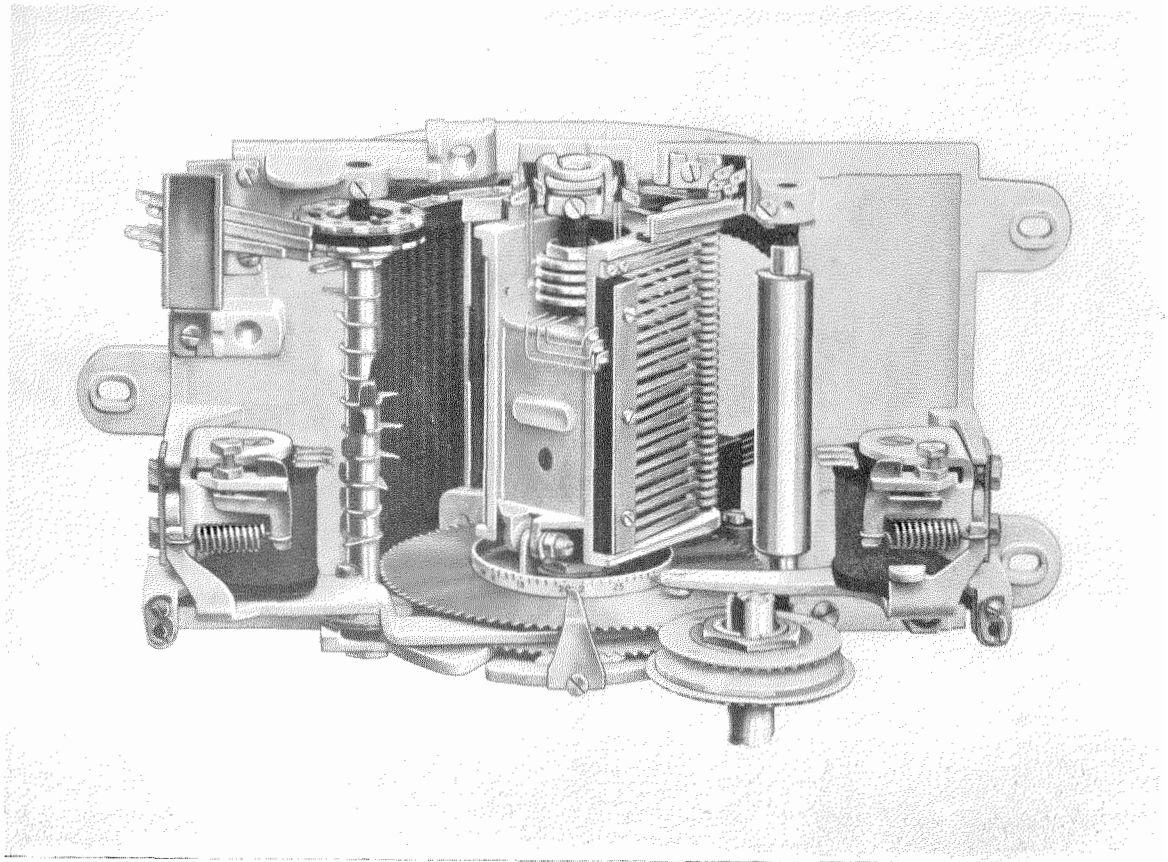

Fig. 13—Final selector differs only slightly from the group selector. There are only 200 circuits on the terminal bank and the brush carriage has a commutator to develop revertive pulses.

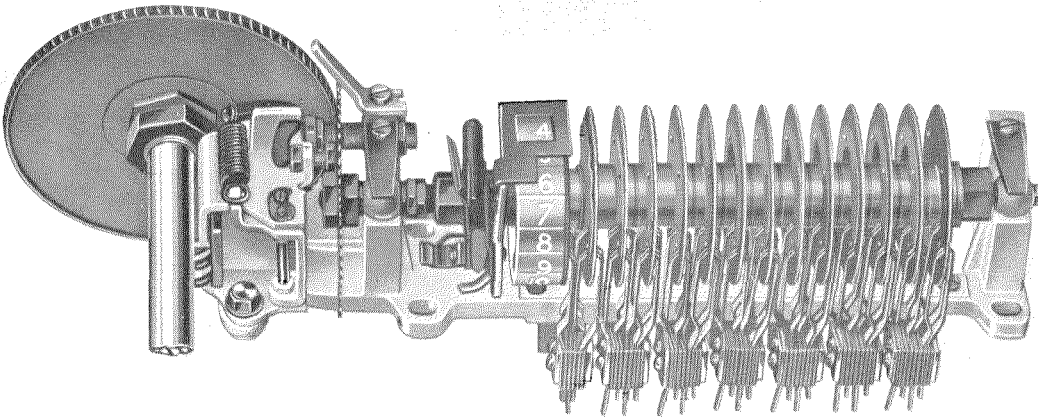

Fig. 14—The sequence switch is power driven and permits 18 different switching conditions over one revolution. It may be used to control such functions as ringing, "busy" signal, or talking circuit. Sequence switches are associated with selectors.

facilitates the many changes of circuit condition required to complete a connection between two subscribers, and it helps to reduce maintenance by simplifying the location of faults.

A shaft of circular cross section carries a number of phosphor-bronze and phenol-fiber disks. A phenol-fiber disk is placed between two phosphor-bronze disks and the three pieces are riveted together. The two phosphor-bronze disks are in contact with each other but insulated from the shaft. This assembly is known as a sequence-switch cam. The phosphor-bronze disks are cut

on a special machine which removes metal from the positions where it is not required.

Flexible phosphor-bronze springs make contact with the disks and are arranged in groups of four, two for each side of a cam. Appropriate cutting of the cam permits circuits to be closed between any of the 4 brushes in any position of the switch. The shaft carries a translucent position indicator illuminated by a small lamp and enables the maintenance force to observe readily the position of the switch.

A flexible gear drives the cam shaft one

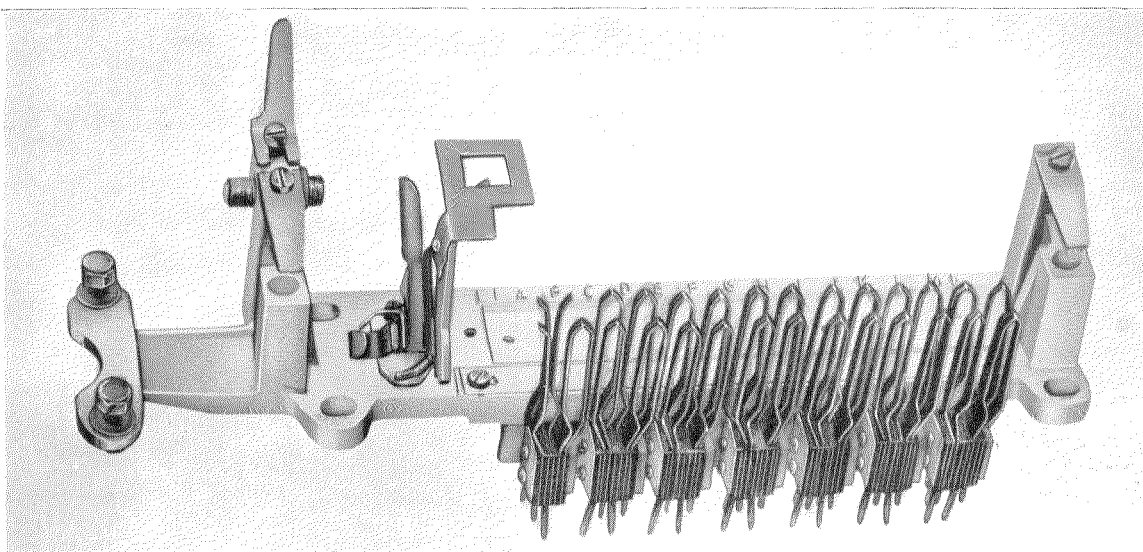

Fig. 15—Sequence-switch frame.

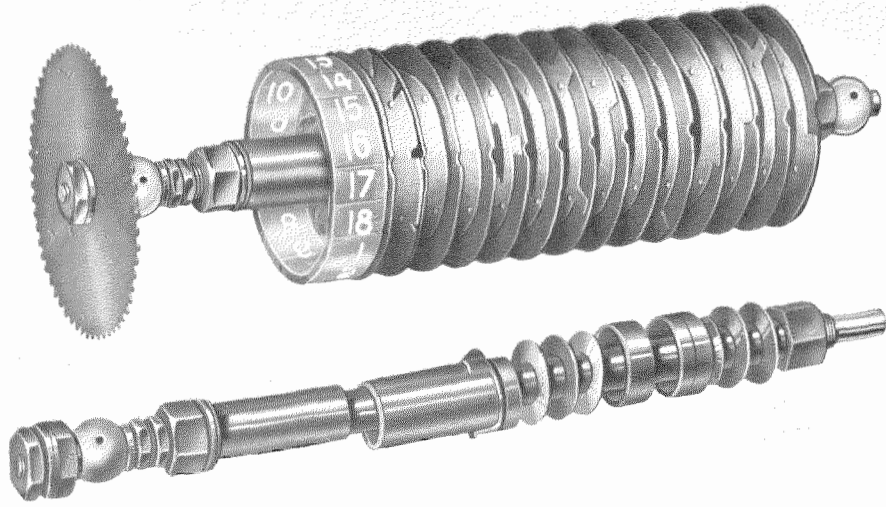

Fig. 16—Cam-shaft assembly of sequence switch.

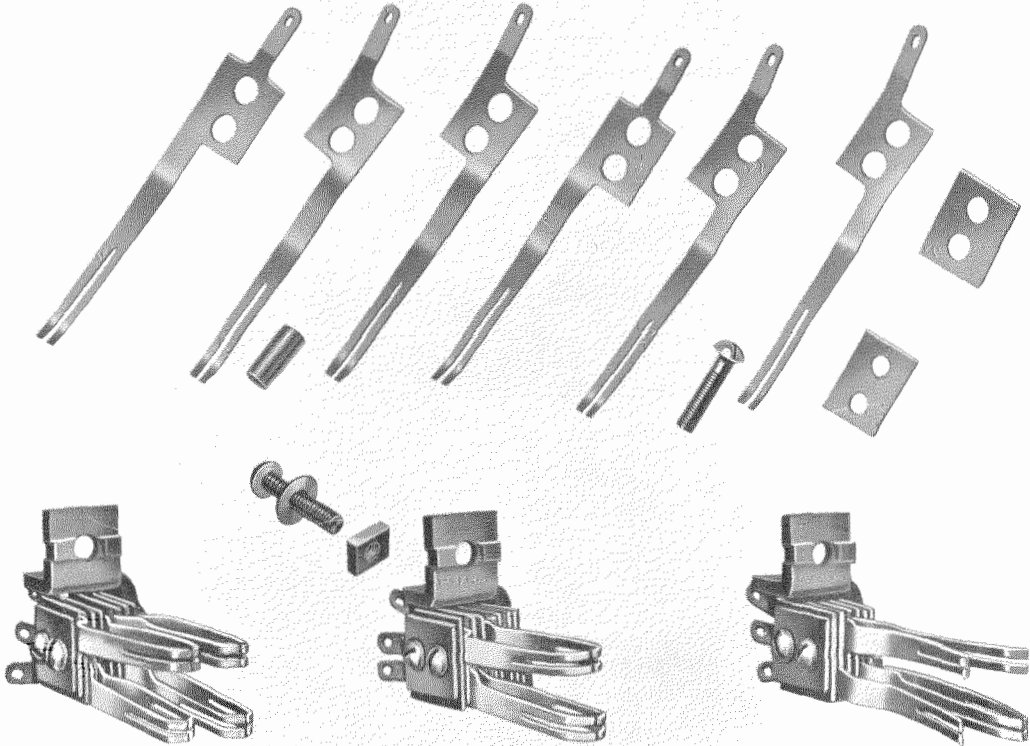

Fig. 17—Springs and assemblies for sequence switches.

revolution for each connection and the 360 degrees are divided into steps of 20 degrees each. The steps are known as sequence-switch positions and are numbered 1 to 18. Each position of the switch is usually devoted to some particular circuit condition. For example, the sequence switch of the penultimate group selector in position 9 connects the "busy tone," in positions 12 and 13 connects the immediate or initial pulse of ringing current, in position 14 connects the interrupted ringing, and in position 15 connects the talking circuit. The principal components of the sequence switch are shown in Figs. 15, 16, 17, and 18.

2 Equipment

2.1 FINDER-SWITCH BAYS

The apparatus just described is not shipped loose but is mounted in units termed "bays" which are completely wired and tested in the factory. Such a bay is shown in Fig. 19.

A fully equipped finder-switch bay carries 22 regular finders and one special finder switch used in connection with automatic ticketing to identify a subscriber calling long distance. The same switch is also used to identify lines with a trouble condition and flash the number of the line to the wire chief.

The bay carries a vertical shaft equipped with 23 driving gears, one for each switch. Line and cut-off relays, together with circuit fuses for 200 lines, are mounted on the top portion of the bay and wired to terminal strips. The finder-switch banks are multiplied with silk-insulated ribbon cable and the top bank is connected to the bay terminal strips with regular cellulose-

acetate-insulated switchboard wire. The rear of the bay is protected with a light metallic aluminum-finished shield.

This bay is a complete finder switch and relay unit for 200 lines and is installed by mounting on the switch rack and cabling from the top terminal strips to the main or intermediate distributing frame. Fifty such bays are required for a 10 000-line unit.

A selector bay carries 20 complete selector circuits, each circuit comprising the selector itself, a sequence switch, and a number of relays. The selectors and sequence switches are driven from a common vertical shaft equipped with 20 sets of driving gears. The selector banks are multiplied with silk-insulated ribbon cable and connected to terminal strips at the top of the bay. Each circuit is provided with an individual alarm-type fuse mounted alongside the switch and wired to the bay fuse, also of the alarm type, at the top of the bay. Except on toll circuits, the same battery supply is used for both signalling and talking circuits.

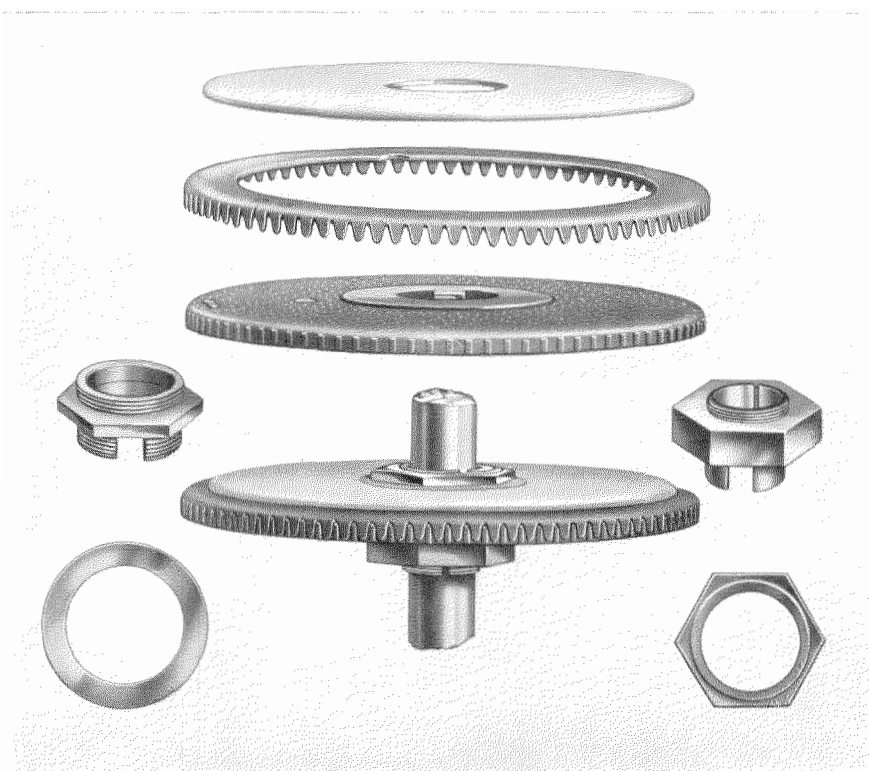

Fig. 18—Driving-gear assembly for sequence switch.

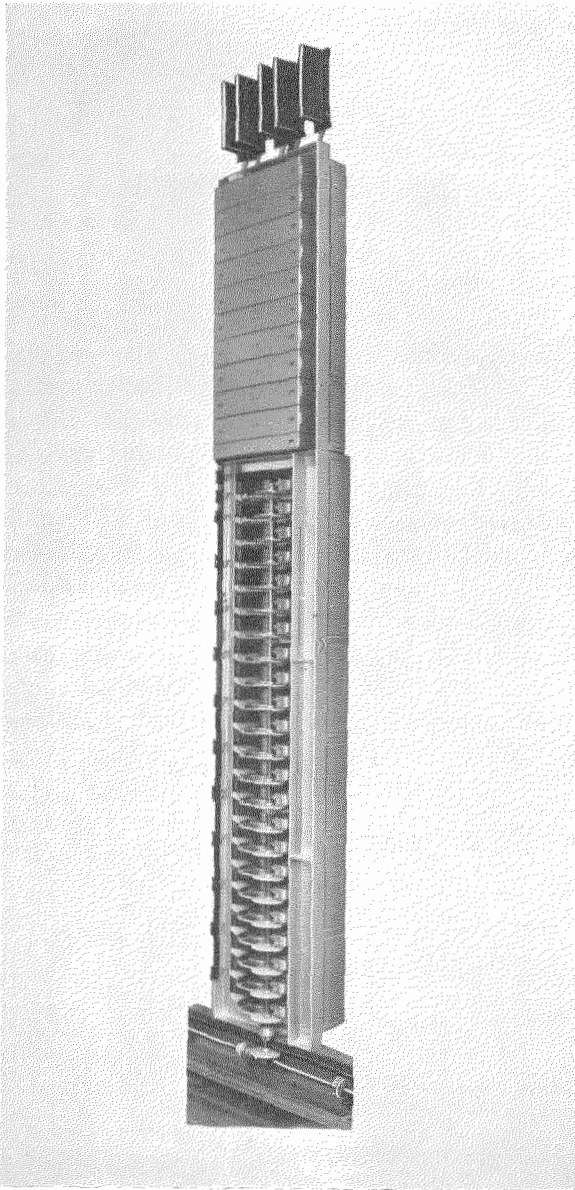

Fig. 19—Finder-switch bay which leaves the factory as a complete and tested unit.

2.2 FUSES

The circuit fuses of the rotary system are of the plug-in type and replace the well-known screw-connected grasshopper type of fuse. The plug-in type of fuse can be used to disconnect the battery readily from a circuit during fault investigation or mechanical inspection of the apparatus. The capacity of the circuit fuses is $1\frac{1}{3}$ amperes and the bay fuse is 6 amperes.

3 Operation of Rotary System

Fig. 24 shows in diagrammatic form, the arrangement and number of switches required for a medium-traffic office of 10 000 lines, forming part of a multioffice network. The busy-hour traffic is expressed in 2-minute units termed "equated busy-hour calls" (EBHC), and in this particular example each subscriber originates 1.5 equated busy-hour calls during the busy hour. The total busy-hour traffic is therefore 15 000 equated busy-hour calls of which amount 8500 are out-

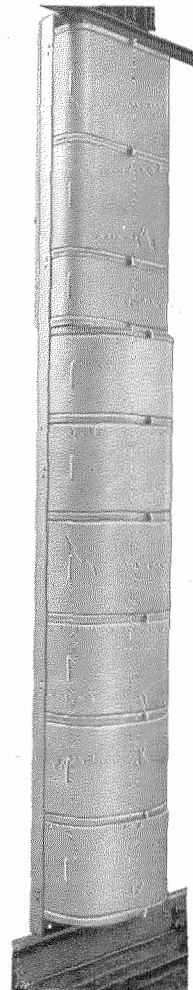

Fig. 20—Rear view of finder-switch bay.

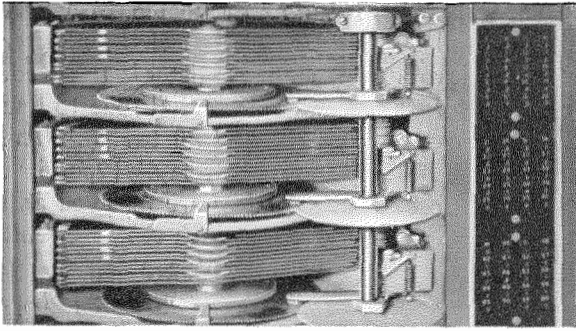

Fig. 21—Close-up view of finder switches mounted in bay.

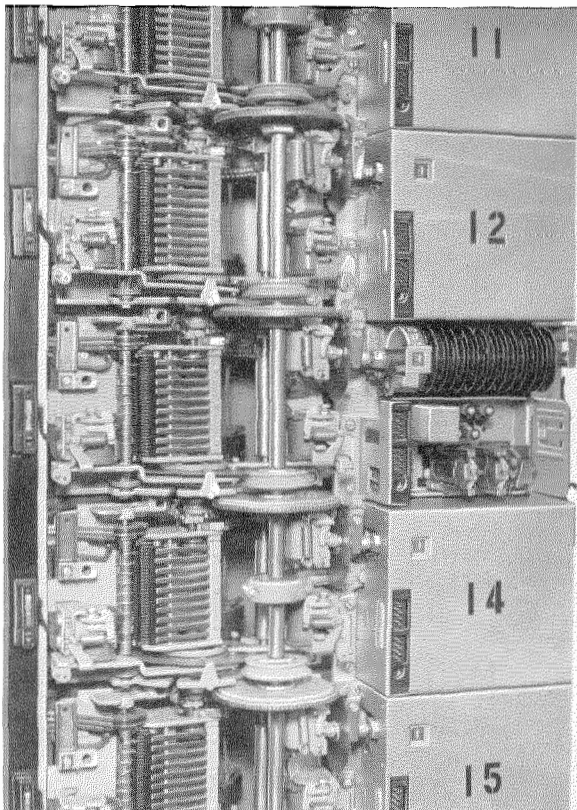

Fig. 22—Close-up view of a selector bay.

going to other offices, to long distance, and to various special services such as information. The traffic incoming from other offices is 7500 equated busy-hour calls and incoming from toll is 1500 equated busy-hour calls.

To carry this traffic, 1050 finder switches are required, arranged in 50 groups of 21 switches. The selector equipment includes 800 first selectors and 800 penultimate selectors. The final selectors or connectors total 950, arranged in 50 groups of 19. Incoming traffic requires 480 in-

coming group selectors. A link circuit is used to permit any one of the 800 first selectors to be connected to any one of the 90 sender or register circuits. 160 of these link circuits are required and each has 2 finder switches, designated register finder and selector finder, respectively.

A connection between two subscribers of this office would proceed as follows: The line calling condition is the removal of the handset from the cradle, causing the line relay to operate. The finder switches of the group of 200 lines to which the calling line is connected now rotate. If there are no other calls in the group, 15 switches will rotate simultaneously to find the line. The finders are nonhoming switches and the average time to find the line is therefore approximately $\frac{1}{4}$ second.

It is possible that 2 or more finders may simultaneously reach a line in the calling condition but this is not harmful since an ingenious but simple

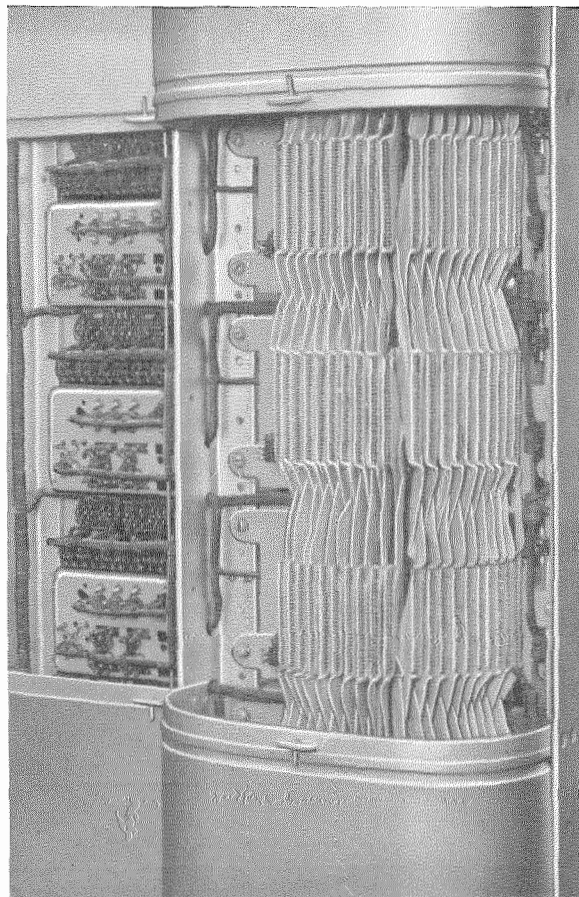

Fig. 23.—Rear view of a selector bay. The silk-insulated ribbon cable which multiples the terminal banks is much in evidence.

arrangement of 2 relays prevents more than one finder from stopping on the terminal. This is known as the "double-test" feature, and is included in all rotary circuits. The finders are not in any way interconnected with each other and there are no common allotter or preference circuits.

The finder switches are divided in 2 groups, 15 normal finders and 5 peak-traffic finders. The total number of finders is calculated to give a grade of service of one delayed call in 500 and on this basis the 5 peak-traffic finders carry only 13 equated busy-hour calls or 4.3 percent of the total traffic originated in the group of 200 lines.

The 5 peak-traffic finders of each group total 250; instead of being connected straight to 250 first selectors, they are connected through 50 secondary finders to 50 first selectors, thereby reducing the total number of first selectors from 1000 (750+250) to 800 (750+50).

The peak-traffic finders do not become active until all but one of the normal finders of the group are engaged.

The calling line is now connected to a first selector and both finder switches of the register link circuit rotate until a free register is attached. The register or sender connects dial tone to line and receives the pulses sent from the dial. The sender circuit is of the "all-relay" type, i.e., both dial and revertive pulses are received and stored on high-speed relays. Each sender circuit has two sequence switches, one controlling the dial pulses and the other the revertive pulses. The easiest way to understand the sender circuit is to think of it as two separate circuits, one designed to receive and store 7 sets of dial pulses and the other designed to control 7 selections. There is no fixed relation between the two, and the digits dialed can be translated as required to give different selections. In practice, this feature of translation is usually limited to the first 2 or first 3 digits (or letters) of the number dialed, known as the office code.

In Rochester each office will have a 2-letter code followed by the 4 digits of the subscriber's number. When the office code is received in the sender it is translated to select the required level on the first selector.

The Rochester layout requires one more stage of selection than is shown on the diagram, the additional selector being known as the third group selector. The first selector chooses the required office and the third, penultimate, and final selectors, the thousands, hundreds, tens, and units.

A feature of all rotary selectors except the final is "continuous hunting." Instead of transmitting a busy tone to the calling subscriber when all circuits on the required level are found occupied, the selector brush carriage continues to rotate until a circuit becomes available. Based on a grade of service of 1 call in 100

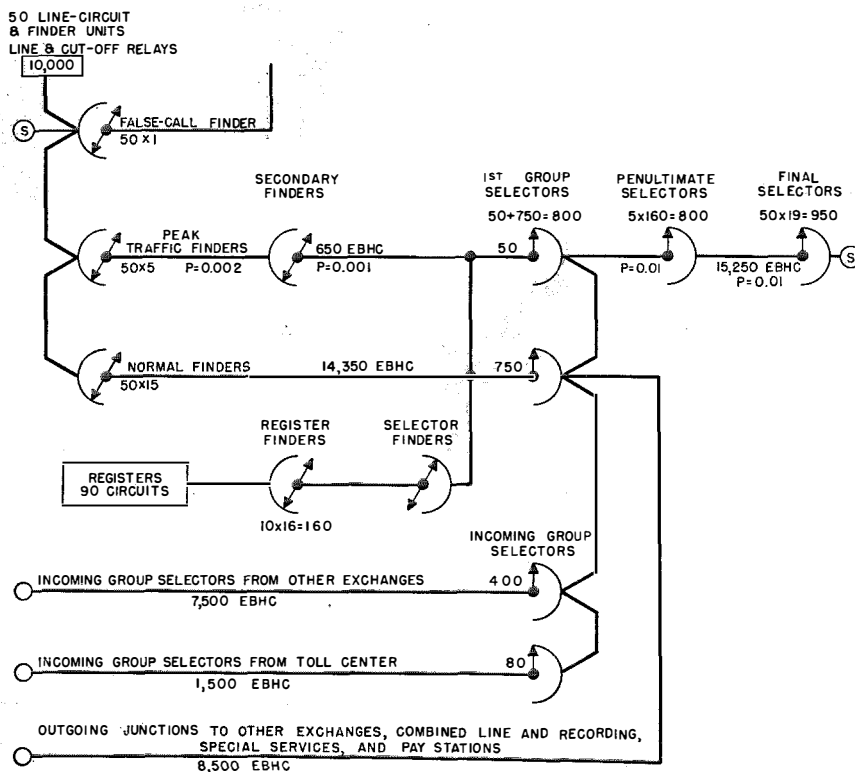

Fig. 24—Typical junction diagram for a 10000-line exchange having a medium calling rate of 1.5 equated busy-hour calls (EBHC) per line. The loads carried by the various circuits are indicated; P = the proportion of calls that are delayed.

being delayed, it follows that 990 calls out of 1000 will be successful on the first attempt. Of the 10 delayed calls, the probability is that 5 will be successful in the second revolution of the selector, 3 in the third revolution, 1 in the fourth, and the tenth will be delayed more than 4 revolutions.

The numbering plan of the rotary system is based on multiples of 200 numbers. The final-selector capacity is 10 levels of 20 numbers, a total of 200. The penultimate-selector capacity is 10 levels of 200 numbers, a total of 2000; and the third selector capacity is 10 levels of 2000 numbers, a total of 20000.

Odd and even thousands are paired on each level of the third selector, and odd and even hundreds are paired on each level of the penultimate selector.

At the final selector, subscribers numbered in the even hundreds are connected to the first 10 terminals of each level and the subscribers numbered in the odd hundreds, to the second 10 terminals. The final selector functions as follows:

The trip spindle of the selector is positioned in accordance with the tens digit dialed and, therefore, determines the level or group of 20 lines containing the called number. The last selection is dependent on the units digit dialed but in the case of an odd hundreds digit the brush carriage must move an additional 10 steps to bring it in position to select from the last 10 lines of the chosen level.

Segregation of final selectors for different classes of service is not necessary in the rotary

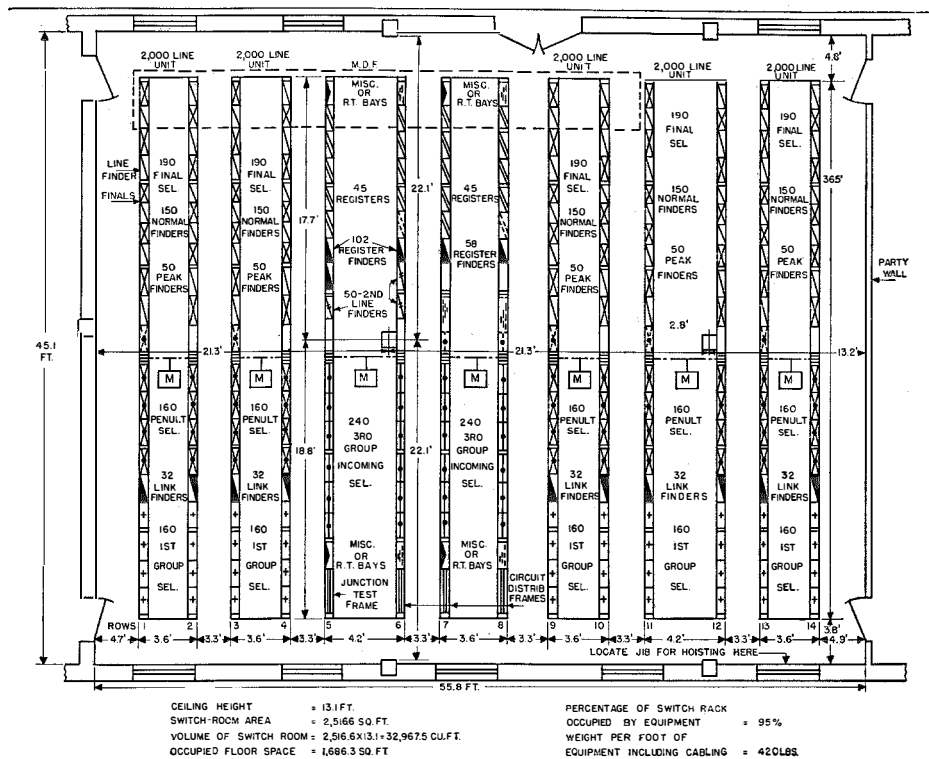

Fig. 25—Switch-room layout for an exchange having the junction diagram of Fig. 24.

system. Each group may have connected private automatic branch exchange lines, party lines, and main lines, and each selector serves for both local and toll connections. This is a great advantage since, when segregating into small groups for different classes of service, it is difficult to estimate the traffic in each group with the resultant danger of overload on circuits designed for one class of service while other services may have too many circuits.

3.1 PARTY LINES

The Rochester plan is to connect both 2- and 4-party lines on a terminal-per-station basis as distinct from a terminal-per-line basis. This means that party-line stations will not have an additional digit known as a "ring digit" and will be listed in the directory as regular 6-digit subscribers. Any 4 directory numbers may be used to make up a 4-party line. Harmonic ringing is used to select the required station, and in other systems this is usually accomplished by providing special groups of final selectors each with a different ringing frequency and connecting the 4 stations to 4 different selector groups.

With this scheme it is difficult to estimate how many final selectors are required for each ringing frequency. Further, since a given group of final selectors and therefore a given group of directory numbers is limited to one particular frequency, movement of stations from one 4-party line to another results in many number changes.

The rotary party-line circuit enables a party-line station to be allotted a directory number without reference to the ringing frequency. This is accomplished by 2 relays per party line which determine the ringing frequency for each one of the 4 stations.

3.2 SWITCH-ROOM LAYOUT

Fig. 25 shows a typical switch-room layout in accordance with the junction diagram shown in Fig. 24. The switch-rack layout is planned to mount the equipment as far as possible in units of 2000 lines, thus facilitating tracing of connections and at the same time reducing the amount of interbay and multiple cabling. The sender circuits are placed on switch racks in the center of the room. This layout requires 14 racks and each rack is equipped with a horizontal shaft which is driven from a $\frac{1}{8}$ -horsepower duplex motor common to each pair of racks. The racks numbered 1 to 4 and 9 to 14 are arranged in pairs, each pair carrying the line and selector equipment for 2000 lines. Finder-switch and final-selector bays are mounted adjacent to each other and these 20 bays occupy approximately half the rack length. There are 8 bays of penultimate selectors, 2 bays of link finders, and 8 bays of first group selectors. There is also space for one bay of routine test equipment and one spare. The register circuits and register finders are mounted on racks numbered 5, 6, 7, and 8 together with group selectors for traffic incoming from other offices and from toll. There are 18 bays of register circuits which mount 5 per bay and 5 bays of register finders. The switch-room dimensions are as follows:

Length = 55.8 feet

Breadth = 45.1 feet

Height = 13.1 feet

4 Maintenance of Central-Office Equipment

Maintenance is an important item in the operating costs of central-office equipment and preventive maintenance usually results in better service at lower costs than the system of waiting for troubles to show up and then removing them.

A typical 10 000-line rotary office has 10 000 line relays, 10 000 cut-off relays, 1370 finder switches, 3030 selector circuits, 90 sender circuits, 450 outgoing circuits, switchboard cable, ribbon cable, terminal strips, and a large number of soldered joints.

This equipment is maintained by routine testing which is performed automatically during regular hours of maintenance and does not require removal of circuits from their place of operation to a test bench. The routine test equipment is not accessory equipment. It is permanently wired and forms part of the fundamental design of the rotary system. The test equipment is connected to the circuits under test by means of access switches arranged to move from circuit to circuit until all have been tested. The test results may be recorded by a tape perforator, or the operation can be changed by a control key to stop the test and give an alarm when a fault condition is encountered.

5 Conclusion

Time does not permit a description of many other interesting features of the rotary system such as different methods of metering: single, multiple, time and zone, and automatic ticketing; the operation of large multioffice networks including interworking with manual exchanges; different methods of translation; and long-distance dialing; but in closing, I would like to say that the Rochester equipment is designed to fit in with the Bell System plans for nationwide toll operator dialing.

Rotary Equipment of The Hague District

By D. A. ALBERTS

Engineer, Dutch Administration of Posts, Telegraphs, and Telephones, 's Gravenhage, The Netherlands

J. P. VERLOOY

Manager, Nederlandsche Standard Electric Mij. n.v., 's Gravenhage, The Netherlands

THE first Rotary Automatic telephone switching equipment for The Hague was put in service over 25 years ago. Complete conversion of The Hague district to rotary operation was interrupted by World War II and this program has now been resumed. Co-ordination with the national dialling scheme has required certain modifications of equipment and operating practices. The Hague main district exchange and the secondary and tertiary offices associated with it are described.

• • •

The general plan of the telephone network of the Netherlands and the 20 telephone zones or districts into which the country is divided have been described^{1,2,3} previously and includes a numbering scheme under which each exchange is allotted a prefix. The district of Haarlem is the first to be completely equipped with Rotary Automatic telephone equipment. A year before the war, conversion of The Hague district had started. This work, interrupted by the war, is now being continued.

On the west, The Hague district follows the North Sea coast from the Haarlem district to the Hook of Holland where it reaches the river Meuse. Adjacent districts to the North and East are those of Haarlem, Amsterdam, Utrecht, and Rotterdam.

Under the general plan for national dialling, the zone center is termed the "primary exchange," provincial exchanges connected to the zone center are called "secondary exchanges," and rural exchanges connected to the secondary exchanges are known as "tertiary" or "end" exchanges. A geographical layout of The Hague

zone is given in Figs. 1 and 2. The Hague, as zone center, is allotted the prefix K 1700.

There are 4 secondary exchanges as shown in Table I.

TABLE I

Exchange	Prefix	Kilometers from The Hague
Leyden	K 1710	16
Alphen a/d Rijn	K 1720	25
Delft	K 1730	8
Naaldwijk	K 1740	12

1 The Hague City

The first rotary equipment for The Hague was manufactured 30 years ago and it is of interest to trace briefly its development during the intervening years.

The first automatic exchange of this city, "Scheveningen," was built during the 1914-1918 war. The original order was for 2200 semiautomatic lines. Traffic from the manual exchange of the city passed over order wires and was further handled by semi-B operators located at Scheveningen. Outgoing calls to the manual office arrived on call-indicator positions and were completed in the manual multiple.

This exchange was put into service in the early days of 1920 with 3400 semiautomatic subscriber lines. Conversion to full-automatic working took place some time later after which there were several extensions. At present the original equipment converted to full-automatic operation is still in service. The second automatic office was "Marnix" which was put into service in February, 1921, with 4000 semiautomatic lines. Marnix was later converted to full-automatic operation and further exchanges have been gradually added.

At the beginning of the war, The Hague local area consisted of 12 offices with equipment for 51 600 subscriber lines. This equipment is of the 7-A, 7-A1, and 7-A2 systems.

Meanwhile plans were being evolved for full-automatic long-distance connections. In 1937,

¹F. O. Bloembergen, "The 7-D Automatic Telephone System in the Haarlem Rural Area," *Electrical Communication*, v. 12, pp. 63-75; October, 1933.

²J. P. Verlooy and M. den Hertog, "National Dialling in the Netherlands," *Electrical Communication*, v. 17, pp. 78-87; July, 1938.

³B. A. Turkhud, "The Hague Telephone Network," *Electrical Communication*, v. 4, pp. 221-242; April, 1926.



Fig. 1—Telephone zones of the Netherlands.

The Hague Municipality was faced with the problem of providing facilities for full-automatic long-distance connections with the rotary exchanges of the city. Solution of this problem required some system of metering outgoing long-distance connections that would be satisfactory to both The Hague Municipality and the Administration of Posts, Telegraphs, and Telephones. It was necessary to meter local Hague connections separately from long-distance connections, local calls having a standard charge, which is independent of time, and toll calls being metered on a time and distance basis. Furthermore, accounting of local calls was by The Hague Municipality while that of toll calls was by the Dutch Administration. Until September, 1940, telephone services of Amsterdam, Rotterdam, and The Hague were provided by the respective municipalities, while telephone

services in the remaining part of the country were in the hands of the Administration of Posts, Telegraphs, and Telephones. Since then, the entire telephone network of the country has been owned and operated by the Posts, Telegraphs, and Telephones Administration.

Naturally there were numerous other problems to be solved before the existing automatic equipment could be co-ordinated with the national dialling scheme of Holland. These problems were solved by introducing an entirely separate train of switches for handling outgoing toll traffic. This avoided extensive modification of the existing system and made an increase in floor space unnecessary.

The Hague main district exchange is the full-automatic toll exchange for the entire Hague district. It serves as the trunking center for connections between The Hague, The Hague district, and the rest of the Netherlands.

Before cut over of the district exchange, all toll calls were handled over a semiautomatic toll board. This toll board had to carry a heavy load which diminished in proportion to toll traffic that passed over the district exchange.

A tertiary exchange in Wassenaar is connected to the district exchange. Wassenaar is working with 7-D equipment for 2000 lines. A second tertiary exchange, connected directly to The Hague district office, is Leidschendam. The equipment of this exchange, 400 lines, also of the 7-D type, will be put into service shortly. Prefixes for Wassenaar and Leidschendam are, respectively, K 1751 and K 1761.

2 Leyden Sector

On July 4, 1939, the first of the secondary exchanges was opened in the ancient university

town of Leyden on the Old Rhine, perhaps best known to readers of *ELECTRICAL COMMUNICATION* as the town from which the Leyden jar takes its name. The Leyden exchange, with a capacity of 12 000 subscriber lines and an equipment of 7000 lines, has been the largest 7-D office in service in the Netherlands.

During the first year of operation, the Leyden automatic exchange provided local service only. For toll traffic, a temporary arrangement was made whereby the 18 existing toll switchboard positions were provided with dials. Trunklines between the toll board and the automatic exchange were jack ended; 10 jacks were individual to each section of 2 positions, and a group of 20 jacks were multiplied over all sections (the common jacks are associated with busy lamps). In 1940, a temporary district equipment was installed in the existing Hague toll office and connected the Leyden and Wassenaar exchanges to The Hague for full-automatic switching. In 1942, at the opening of The Hague main district office, this temporary equipment was replaced.

The Leyden sector includes 8 tertiary exchanges, largest of which are Noordwijk (K 1719) and Katwijk (K 1718), each having an equipment of 1000 lines. These two offices are in service as is the 400-line exchange Voor- schoten (K 1717).

To the Leyden district equipment are also connected Warmond (300 lines), Roelofarendsveen (300 lines), Koudekerk (200 lines), and the 100-line boards of Zoeterwoude and Rijpwetering. These latter boards are registerless exchanges. Two-way junctions are provided between Leyden and the 100-line boards. For traffic with the larger end exchanges, 1-way and 2-way junctions are used.

Automatic equipment for all the tertiary exchanges of the Leyden sector is ready to be cut over. As a result of the war, local cable work for these offices has not been completed, but it is expected that the entire Leyden sector will be in service within a few months.

3 Naaldwijk Sector

The secondary exchange of Naaldwijk will be the second of The Hague zone to be put into service. This exchange will have 800 subscriber lines and will be equipped for interworking with 5 tertiary or end exchanges. Table II gives data on these exchanges.

TABLE II

Exchange	Prefix	Lines Equipped
Naaldwijk	K 1740	800
Monster	K 1749	600
Hook of Holland	K 1747	400
De Lier	K 1745	300
Wateringen	K 1742	400
's-Gravenzande	K 1748	400

The equipment for this Naaldwijk sector was manufactured in the early days of the war and installation has been started. Cut over of this sector is planned for the end of this year.

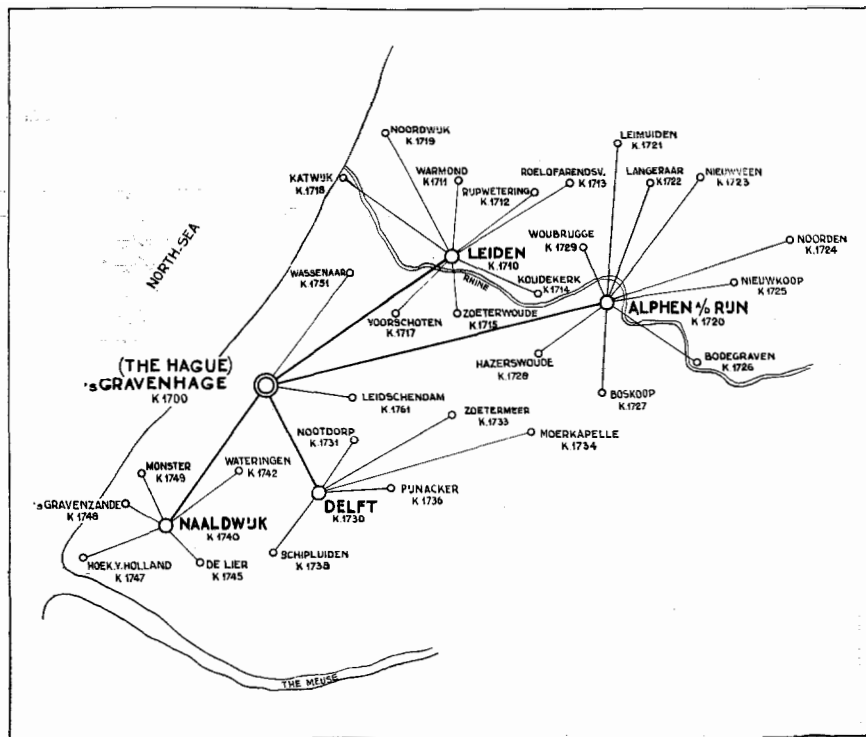

Fig. 2—The Hague zone.

4 Delft Sector

Delft, famous for its pottery, will also need a secondary exchange. This equipment will be similar to that of Leyden. An initial 5000 lines will be required. Five tertiary exchanges will be connected to the Delft sector, as given in Table III.

TABLE III

Exchange	Prefix	Lines Equipped
Schipluiden	K 1738	200
Nootdorp	K 1731	200
Pijnacker	K 1736	400
Moerkapelle	K 1734	200
Zoetermeer	K 1733	600

At present Delft is still working on a manual basis. As no building is available for housing automatic equipment, the automatization has been temporarily postponed.

5 Alphen a/d Rijn Sector

The next secondary exchange is Alphen a/d Rijn which includes 9 tertiary exchanges as shown in Fig. 2. Conditions are similar to the Delft sector, and automatization of Alphen a/d Rijn will take place in the near future.

6 The Hague Main District Exchange

The Hague main district exchange was installed between 1940 and 1943 in a new building adjacent to the old post office in which the toll board is still housed. The equipment is of the 7-D rotary type and was manufactured by Bell Telephone Manufacturing Company of Antwerp; installation was by the Nederlandsche Standard Electric Mij. n.v., The Hague. Part of this

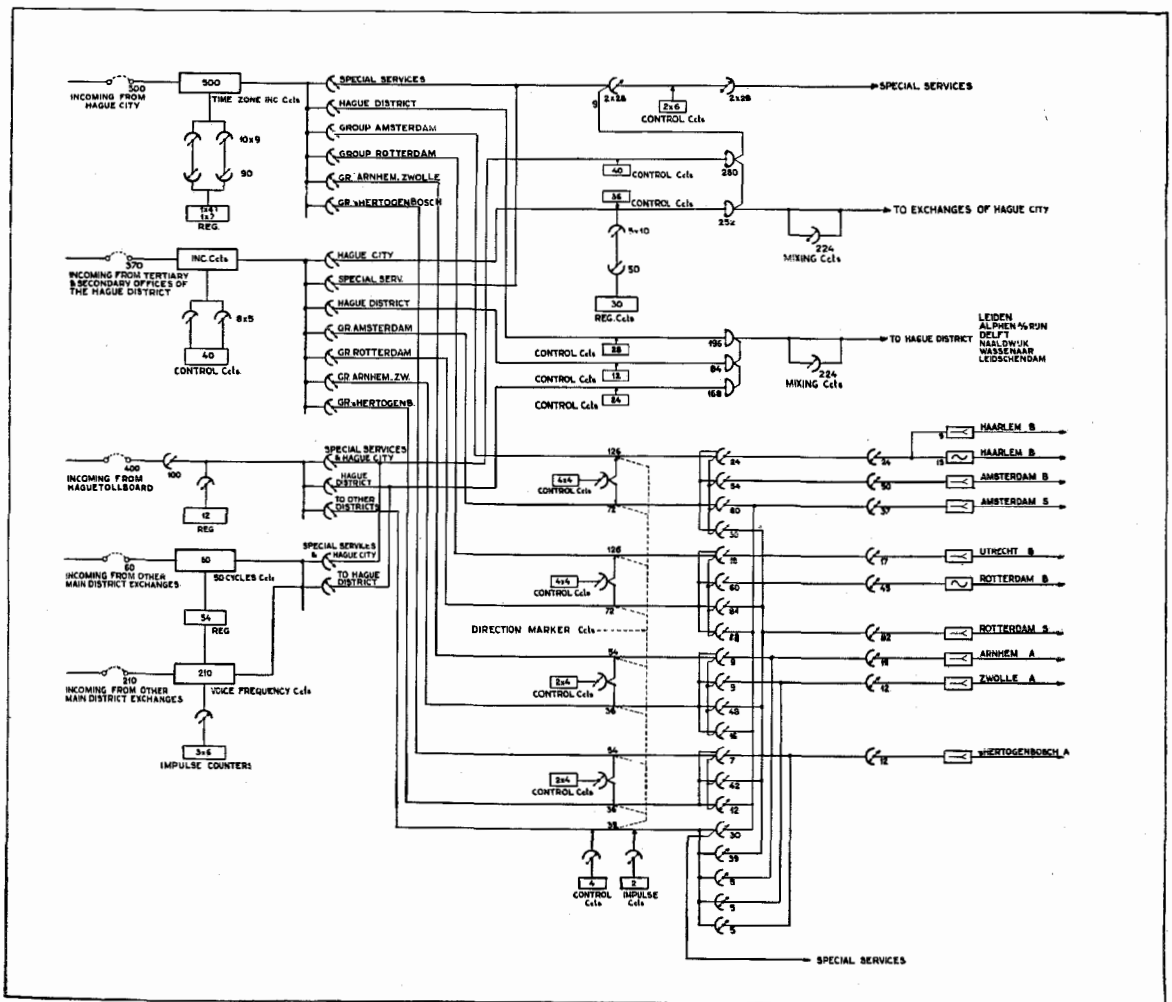

Fig. 3—Junction diagram of The Hague main district exchange.

district exchange was put into service in September, 1942.

Fig. 3 shows the junction diagram of the exchange.

Incoming circuits receive calls from:

- a. The Hague local area (500 circuits).
- b. Secondary and tertiary exchanges (370 circuits).
- c. Toll positions in the old post office (400 circuits).
- d. Other main district exchanges (210 4-wire and 60 2-wire circuits).

Outgoing circuits handle traffic to:

- e. 4 local main exchanges of 7-A type (490 circuits).
- f. Special services (100 circuits).
- g. Secondary and tertiary exchanges of 7-D type (406 circuits).
- h. Other main district exchanges (238 4-wire and 60 2-wire circuits).

The open numbering scheme used in the Netherlands network requires 4 prefixes, preceded by the letter K (=0 on the dial). The first figure after K indicates one of the 5 group centers (Amsterdam, Rotterdam, Zwolle, Arnhem, and 's-Hertogenbosch). The second figure determines the district or zone required (primary exchange), the third figure identifies the sector in the zone (secondary exchange), and the fourth figure takes the call to the end or tertiary exchange. When the required exchange is reached, a second dialling tone is heard and the subscriber dials the local number.

Most outstanding feature of The Hague district exchange is the use of finder stages instead of selector stages. Groups of a hundred circuits are multiplied to the banks of finders. These finders are divided into groups for traffic in several directions and are started in accordance with the prefixes dialled. They hunt in backward direction to find the originating call. In Fig. 4 the general arrangement is given. By means of a register or control circuit, a number of free finders for the wanted direction is set in motion. When one finder holds the calling circuit and is stopped, the other finders stop. If no finder is free in the required direction, a signal is given to the control circuit which switches to another

starting wire and places the call over an overflow direction. If it is necessary to make additional selections in the overflow direction, the control circuit attends to this before switching off.

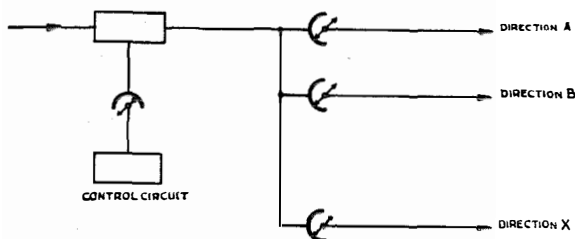

Fig. 4—Direction finders.

6.1 THE HAGUE TOLL CALLS

The 500 incoming lines from the local exchanges of The Hague enter the district exchange over time-zone-metering circuits which are connected over link circuits with a set of registers. The registers receive 4 digits (4 prefixes) to indicate to which exchange in the Netherlands the call is to be put through. The time-zone-circuits are multiplied over 6 groups of finders, one group for each of the directions: special services, Hague district, Amsterdam, Rotterdam, Arnhem, Zwolle, and 's-Hertogenbosch. Each group is subdivided into 5 multiples as a total of 500 lines are connected to the arcs.

Calls to special services pass over a group of link circuits to operators of recording, telegraph, information, and similar services. For these calls, K with two or three prefixes is used.

Calls to The Hague district are established by dialling 17 for the first 2 digits. These calls pass over the above-mentioned finders to a group of selectors connected to a set of control circuits. The third prefix determines the route to the secondary exchange: 1 for Leyden, 2 for Alphen a/d Rijn, 3 for Delft, 4 for Naaldwijk, 5 for Wassenaar, and 6 for Leidschendam. The fourth prefix extends the call to the desired tertiary office and is taken up by switching equipment in the secondary exchange.

Calls to Amsterdam pass to a group of directional circuits. Control circuits associated with the directional circuits receive the next prefix digit and start the finders of the direction Amsterdam. As the number of directional circuits is larger than 100, secondary finders have been

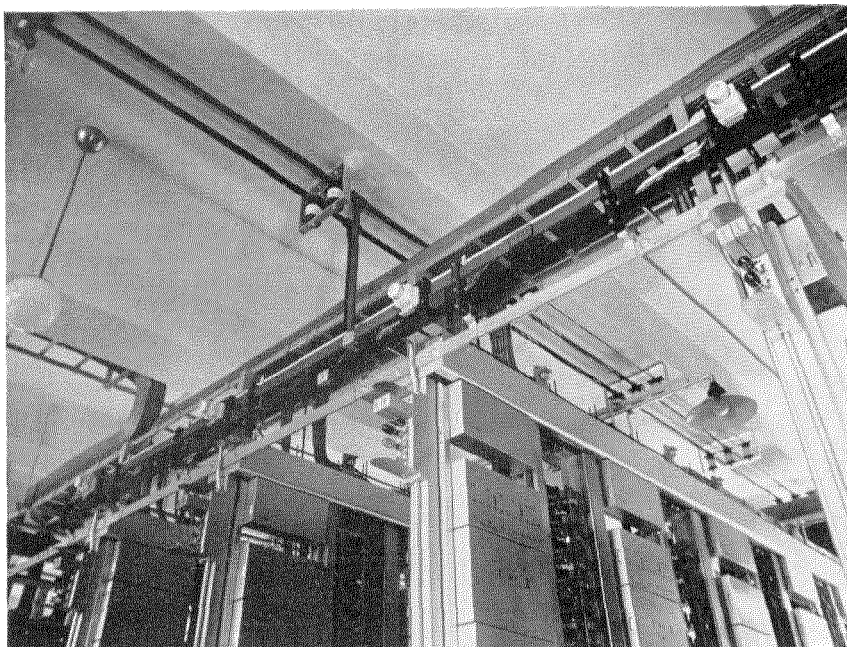

Top of the switch rack of the Leyden exchange.

inserted. These primary and secondary finders between directional circuits and line-relay sets start simultaneously to reduce hunting time.⁴

When the second dialling tone is given by the local exchange, Amsterdam, the calling subscriber dials the local number, which is transmitted directly to Amsterdam and not stored on a register.

Calls to Rotterdam, Arnhem, Zwolle, and 's-Hertogenbosch are established in a similar way.

6.2 TOLL CALLS INVOLVING THE HAGUE SECONDARY EXCHANGES

Incoming traffic from the secondary and tertiary exchanges of The Hague district is handled on the same principles as that from The Hague city. The incoming junctions are connected to control circuits, registers being in the distant office.

Calls incoming from the toll board enter the district exchange over a set of jack circuits. These circuits are connected by means of jack circuit finders with 12 registers.

Incoming traffic from other main district exchanges is handled over 2- and 4-wire relay sets.

⁴ Dutch patent 49 969.

The 2-wire circuits are terminations of non-amplified lines on which 50-cycle alternating current is used for signalling. All 4-wire lines are amplified circuits and signals are given in one direction with 2500- and in the other with 2400-cycle current. The 4-wire lines are either physical lines or carrier channels. Both types of relay sets are connected to incoming registers by relays, 30 lines having a choice of 6 registers. The registers will accept a maximum of 8 digits, 2 as prefixes and 6 for the subscriber number.

These registers are arranged to work with 7-A as well as with 7-D equipment. The line-relay sets are also connected with "impulse counters," special devices for receiving offering and breakdown signals from distant toll operators.

Traffic towards The Hague local exchanges is distributed in the district exchange to the 4 main offices of The Hague city. Two groups of selectors are provided for this purpose, one group for traffic incoming from The Hague district and the other for traffic from the toll board and from other main district exchanges. To obtain high effectiveness for the available number of junctions towards the city, mixing circuits have been introduced.

Traffic to special services is handled over a set of link circuits, each consisting of a finder and a selector. The selectors used for outgoing calls are 100-point finders.

Outgoing calls to offices of The Hague district are handled in the same way as those for The Hague local exchanges. Here also mixing circuits are used.

Calls to subscribers of adjacent districts (Haarlem, Amsterdam, Utrecht, and Rotterdam) pass over 2- or 4-wire trunks to the distant district office. The first 2 prefixes are absorbed

in The Hague district exchange; the third and fourth prefixes indicate the secondary and tertiary office in the required district.

Calls to subscribers of other districts pass over one of the group centers Arnhem, 's-Hertogenbosch, and Zwolle. For these calls only the first prefix is absorbed in The Hague main district office and the second prefix is still required to indicate the district belonging to the group center.

For calls to other districts, *S* directions are also available and act as overflow. For the northern part of the country, Amsterdam is the group center for this overflow traffic; for the southern part, the overflow passes over Rotterdam.

If no direct line to a group center is available, the control circuit immediately switches the starting over to the Amsterdam or Rotterdam *S* direction and gives additional selections so that the required local exchange may be reached. In this case none of the prefixes is absorbed in The Hague main district office.

For the zone of Alkmaar, no direct lines are provided and all traffic has to pass over the Amsterdam *S* group.

All circuits are provided with automatic routine testing. The routine test circuits check on busy circuits for 10 minutes. If the circuit does not become free within this time, an alarm is given. To speed up the test, it is possible to skip busy circuits. In the latter case, meters give the exact number of good, faulty, and busy circuits.

In the entire zone of The Hague, registers test the through-connection of the metering wire to earth before giving dialling tone. If there is an interruption of this wire, dialling tone is not given and the register sets up a connection to an open meter wire circuit on one of the complaint

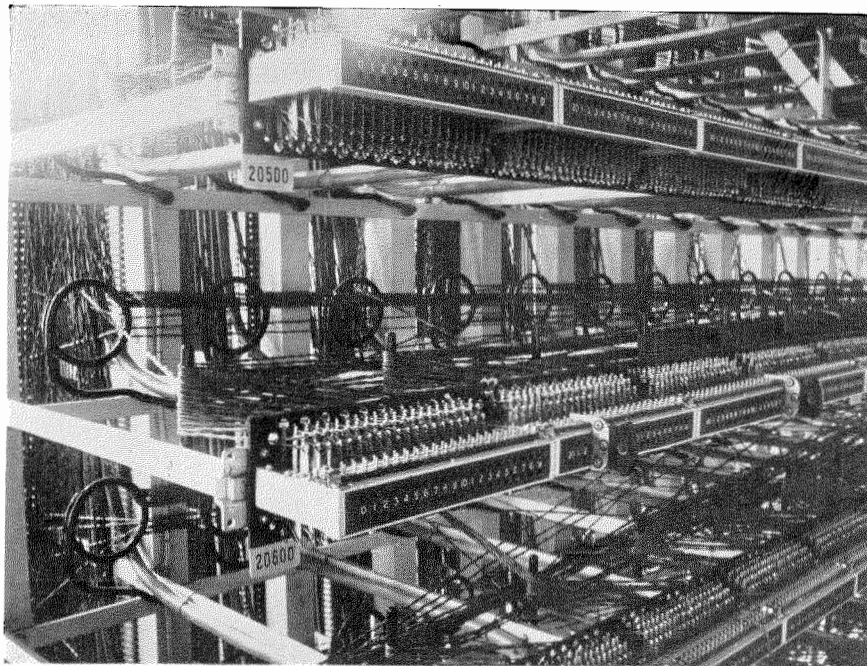

Main distributing frame of the Leyden exchange.

desks in The Hague. The operator asks which connection is desired. She first completes the call for the subscriber through a toll position and then informs the maintenance men of the fault.

The complaint service of the entire Hague zone is centralized in the main district exchange. To obtain the highest efficiency of this service, all exchanges of the zone are provided with circuits which enable the testing of all subscriber lines from the test desks of the district main office. Between the district exchange and the secondary exchanges and between the secondary and tertiary exchanges, the last line in each direction is used for this purpose. A third wire is added to this line to signal the special feature of the call. Testing is sufficiently exact to determine the class of fault, so that either a lineman or an exchange maintenance man may be instructed accordingly.

Two big main distributing frames connect the incoming and outgoing cables to the exchange. The automatic switch room is L shaped; equipment for the incoming circuits is mounted in one leg, and equipment for the outgoing traffic in the other leg. Fig. 5 shows the layout of the racks.

Power equipment consists of two 2030-ampere-hour batteries and 3 charging motor-generators,

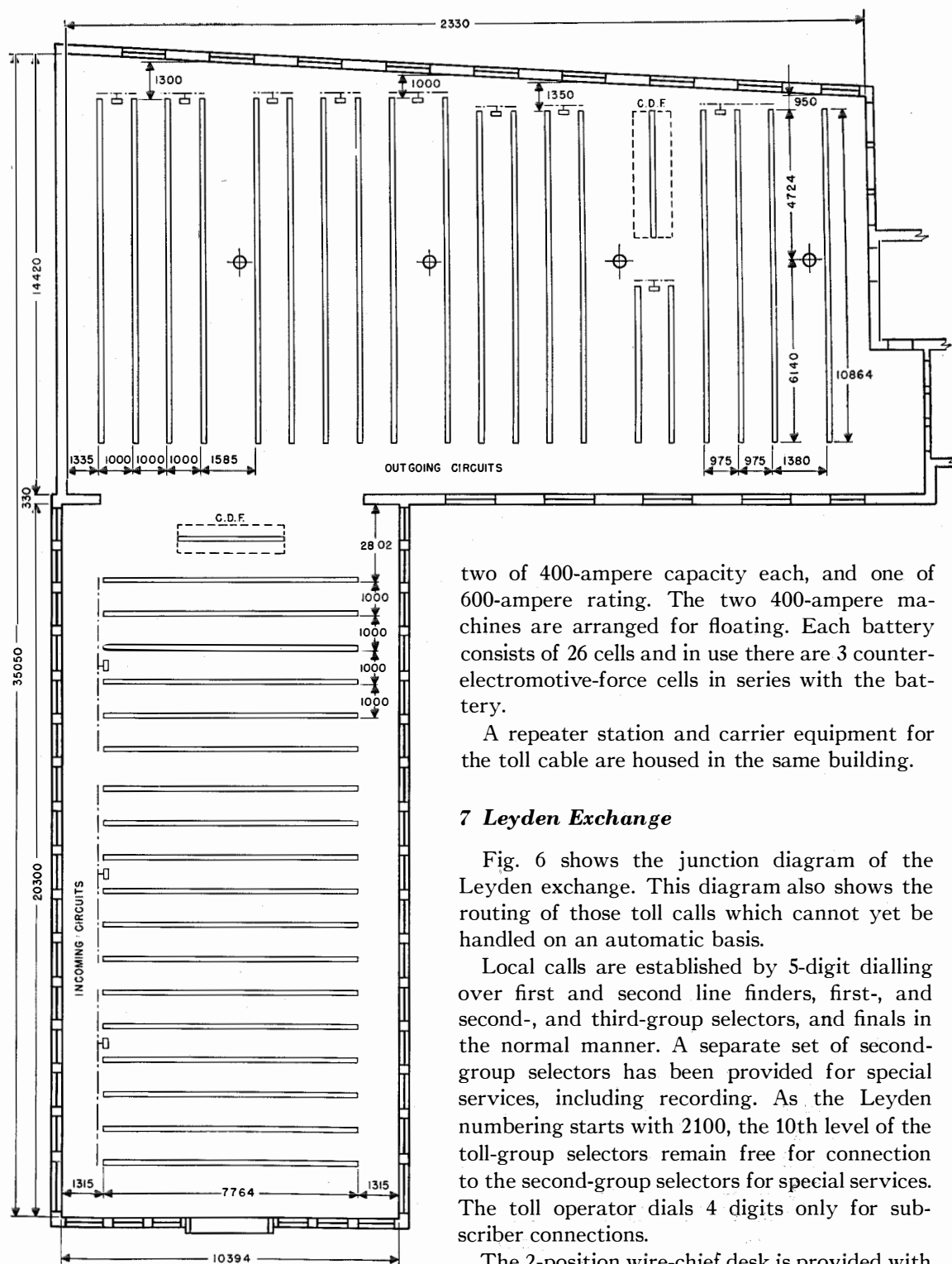

Fig. 5—Floor plan of the automatic switch room in The Hague main district exchange.

two of 400-ampere capacity each, and one of 600-ampere rating. The two 400-ampere machines are arranged for floating. Each battery consists of 26 cells and in use there are 3 counter-electromotive-force cells in series with the battery.

A repeater station and carrier equipment for the toll cable are housed in the same building.

7 Leyden Exchange

Fig. 6 shows the junction diagram of the Leyden exchange. This diagram also shows the routing of those toll calls which cannot yet be handled on an automatic basis.

Local calls are established by 5-digit dialling over first and second line finders, first-, and second-, and third-group selectors, and finals in the normal manner. A separate set of second-group selectors has been provided for special services, including recording. As the Leyden numbering starts with 2100, the 10th level of the toll-group selectors remain free for connection to the second-group selectors for special services. The toll operator dials 4 digits only for subscriber connections.

The 2-position wire-chief desk is provided with one jack per 1000 subscriber lines, which enables the operator by dialling the last 3 figures of a

subscriber's number to connect the test circuit over a wire-chief group selector and a test final to any of the subscriber lines. The 3 digits of the subscriber's number are dialled into a simplified register circuit. In total there are 2 group selectors for wire-chief testing, one for each position. This automatic connection for the wire-chief desk is extended to subscriber lines of the end exchanges belonging to the Leyden sector. One of the finals in each group of 100 subscriber lines is arranged for regular service as well as for wire-chief testing.

The following special features, which have been incorporated in the Leyden equipment, may be of interest.

7.1 TEST JACK STRIPS

Four-point test jacks have been provided for the horizontal side of the main distribution frame. The talking wires, *a* and *b*, can be split and connected, both inside and outside, to the wire-chief desk. The *c* wire can be connected to ground to busy a line (faulty line of a PBX group). The fourth wire, which is connected to the subscriber's service meter, can be used to-

gether with the *a*, *b*, and *c* wires for a subscriber's traffic-control circuit. By means of a special plug, each line can be connected to the information tone to indicate that the dialled line is not obtainable. By dialling K08 an operator will give information concerning this number.

7.2 MALICIOUS-CALL CIRCUITS

Three malicious-call circuits have been provided for the Leyden exchange. A subscriber, whose line is connected to such a malicious-call circuit, may hold the line of a calling party. In case the calling party has restored his receiver, the called party can hold the line by not hanging up his receiver; an alarm will be given by the cord circuit which was in use and the maintenance man in the exchange can trace the number of the calling party. In case the calling party does not hang up his receiver, the called subscriber may dial the figure 1. Here, again, an alarm is given in the exchange and the called subscriber's line will be connected to a second cord circuit which enables the subscriber to call the maintenance man in the exchange.

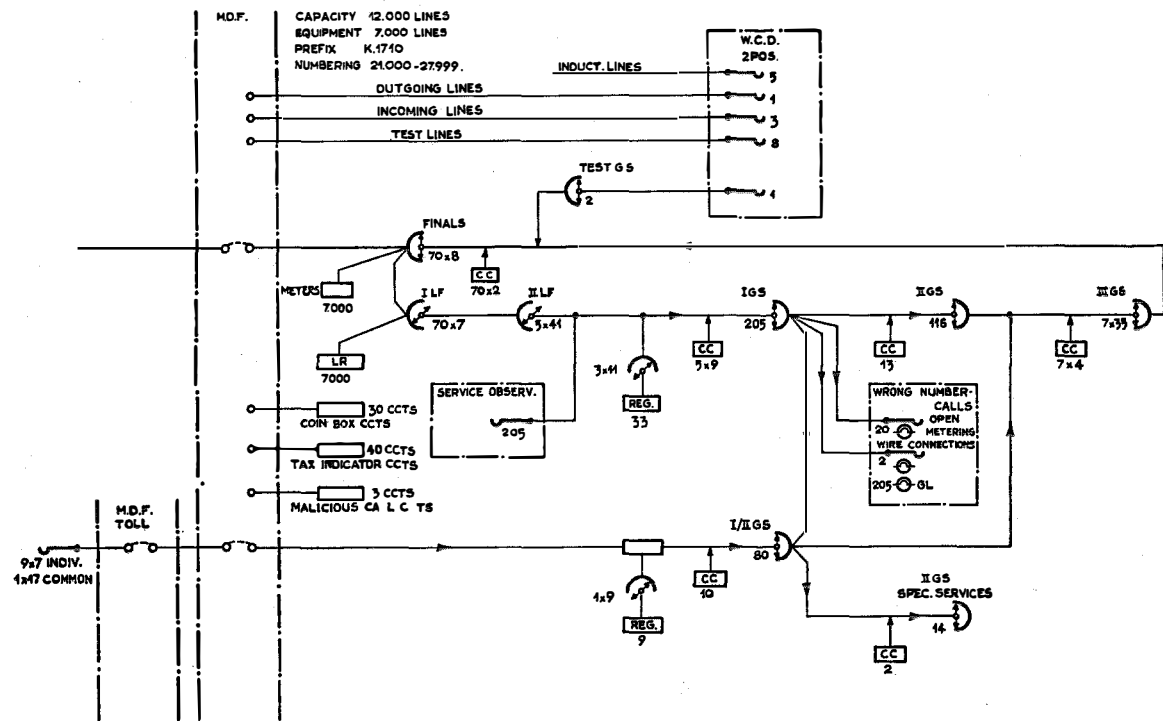
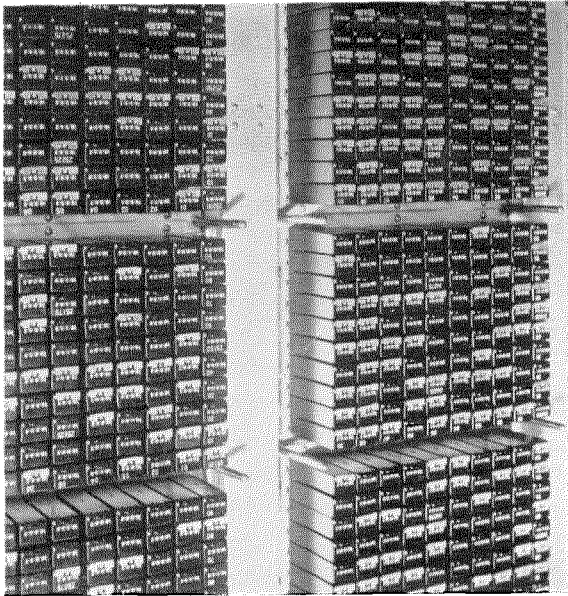

Fig. 6—Junction diagram of the Leyden secondary exchange.



Service meters in the Leyden exchange.

7.3 TRAFFIC RECORDING

All circuits are arranged for traffic recording. The traffic is measured in *TC* units by rotating a selector which connects a point of each circuit to a service meter. A clock circuit starts the traffic recording automatically at a predetermined time. Recording takes place during one hour; it is also possible to arrange for readings to be made for each quarter or half hour.

7.4 ALARM IDENTIFICATION

The alarm identification circuit is arranged so that a code is given for each urgent alarm. During the time that the exchange is unattended, trouble alarms are transferred to the toll board in The Hague. The operator in charge will inform the maintenance man at home by telephone. The maintenance man will dial a 4-digit number and will obtain a code indicating the nature of the trouble. This code is obtained by means of 2 step-by-step switches. Each urgent alarm is represented on the arc of one of the switches. On this switch the alarm contacts are marked and, by means of a buzzer and the second switch which rotates continuously, combinations of dots and dashes are made, giving thus a telegraphic code for each class of alarm. The maintenance

man will know what is happening in the exchange and will act accordingly.

7.5 ROUTINE-TEST CIRCUITS

The routine-test circuits provided in the Leyden exchange are for full-automatic operation. Service meters indicate the number of circuits which do not fulfill the requirements tested by these circuits.

7.6 FALSE CALLS

False calls are routed to special circuits by the registers and are handled by the switch-room maintenance man using a telephone hand set. The false-call circuits end on a panel on a miscellaneous bay. It is possible to connect the howler tone of the wire-chief desk to each of the false-call circuits. The subscriber's line may be measured after locating the cord circuit by means of a key and a lamp.

7.7 SUBSCRIBER'S METERS

Circuits are arranged for multimetering, the fee for toll and trunk calls being a multiple of the fee for a local call. Toll and trunk calls are metered in time units of 3 minutes and according to the distance between calling and called exchanges. The duration of a toll and trunk call is limited to 9 minutes, after which limit the connection is automatically cut off.

The subscriber's meters are mounted in groups of hundreds; mounting plates are provided with guide pins for photographic recording apparatus.

7.8 SERVICE OBSERVATION

The exchange is provided with a test box for service observation. By means of 20 cords, a maximum of 20 link circuits may be connected to this box. The control operator may observe all calls using these links. An indicator shows the number dialled and with a set of service meters the number of calls is observed. Further indications are given concerning the duration of the connection, the talking time, and the number of metering impulses.

The junction diagram for the district equipment in the Leyden exchange is given in Fig. 7.

Incoming traffic from the 100-line registerless exchanges is handled over a separate group of rural link circuits, each link circuit consisting of a line finder and a first-group selector. The first-group selectors are multiplied with the arcs of the local first-group selectors.

Calls from a subscriber of a 100-line board to a subscriber of the Leyden exchange pass over the rural link circuit to the second-group and third-group selectors for local calls to the local final.

Calls incoming from a 100-line board to a subscriber of another 100-line board pass over the rural link circuits and a C-group selector.

Calls from a subscriber of a 100-line board to another tertiary exchange of the Leyden sector pass over the same train of switches as calls to a subscriber of a 100-line board.

Calls from a subscriber of a registerless exchange to a subscriber outside the Leyden sector are directed over the first-group selector of the rural link circuits to an outgoing junction to The Hague district exchange. These last junctions are provided with the time-zone equipment so as to indicate the fee to be paid.

Traffic from a local subscriber of the Leyden exchange to a subscriber of the registerless board is handled over a local first-group selector and a C-group selector. There are two-way junctions between the registerless boards and the Leyden exchange.

Calls incoming from the remaining tertiary exchanges of the Leyden sector pass over the first-group selectors which are multiplied to the arcs of the first-group selectors of the rural junctions and the first-group selectors for local service.

Calls from a local subscriber to a subscriber of the tertiary exchanges

are handled over a local first-group selector and a C-group selector.

The connections for outgoing traffic originating in the local Leyden exchange or in one of the tertiary offices arrive from the arcs of first-group selectors to outgoing junctions. The junctions are provided with time-zone-metering equipment. To obtain the highest possible efficiency for this outgoing traffic to The Hague district exchange, mixing finders have been introduced.

Incoming traffic from The Hague district exchange enters the Leyden exchange over junctions which are connected to the brushes of C-group selectors. From these C-group selectors the connections are made over outgoing junctions to tertiary offices, or to local finals for local traffic.

The Leyden telephone exchange is housed in a new building. The main distributing frame and the wire-chief desk are located on the first floor together with the accumulator room and the power room.

Two batteries, each of 25 cells with a capacity of 2016 ampere-hours (10-hour discharge rate) and 3 counter-electromotive-force cells are provided. The batteries are charged by 2

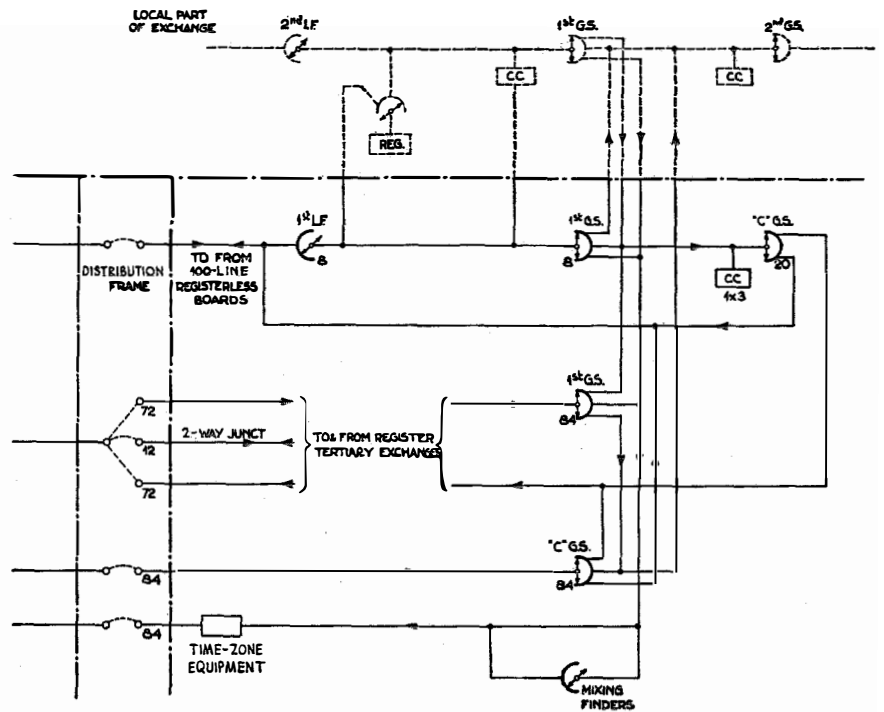

Fig. 7—Junction diagram of the district equipment in the Leyden exchange.

motor-generators, each of these generators giving 200 amperes at 60 to 75 volts; normally one of the batteries floating on a generator serves

rectifier, and an electric air-drying apparatus. The air-drying apparatus is provided with automatic regulation to keep the humidity within required limits.

The power supply consists of a selenium rectifier floating a single battery of 24 cells. Voltage regulation between the limits of 46 and 52 volts is effected by means of a resistance between the rectifier and battery. In case the voltage becomes too high the rectifier is temporarily cut off.

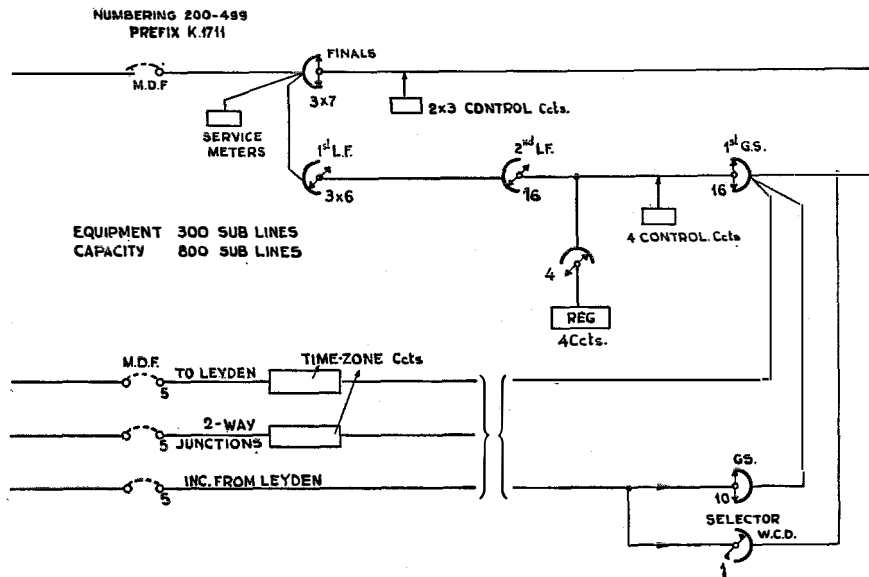

Fig. 8—Junction diagram of the Warmond tertiary exchange in the Leyden sector.

the exchange. Two battery-driven ringing machines have been provided.

8 Tertiary Exchange of the Register Type

Small automatic exchanges with a capacity up to 1000 subscriber lines are unattended. The equipment of these offices only differs in some minor points from that of the larger exchanges.

Traffic being on a low scale it is possible to use bays for 200 subscriber lines with a capacity of 2x7 line finders and 7+8 final selectors (this instead of the normal capacity of 14 line finders and 15 final selectors for 100 subscriber lines).

Fig. 8 shows the junction diagram of Warmond, one of the tertiary exchanges of The Hague district. For each 100 subscriber lines, 6 line finders and 7 finals are provided. The junctions between Leyden and Warmond consist of 5 junctions from Warmond to Leyden, 5 junctions from Leyden to Warmond, and 5 both-way junctions.

The floor plan of the automatic switch room of this exchange is given in Fig. 9. The capacity of the switch room is 1000 subscriber lines. In addition to the automatic switch racks, the room contains a wall-type main distributing frame, a

rectifier, and an electric air-drying apparatus. For offices with an initial equipment of 100 or fewer subscriber lines, the registerless type of exchange is used. The equipment, manufactured in units for 100 subscriber lines, consists of one finder and two relay bays. The junction diagram of such a registerless end office is given in Fig. 10. A calling subscriber is connected over a combined line finder and final circuit to an outgoing junction to the secondary exchange. The dialling tone is given from the secondary office.

9 Tertiary Exchange of Registerless Type

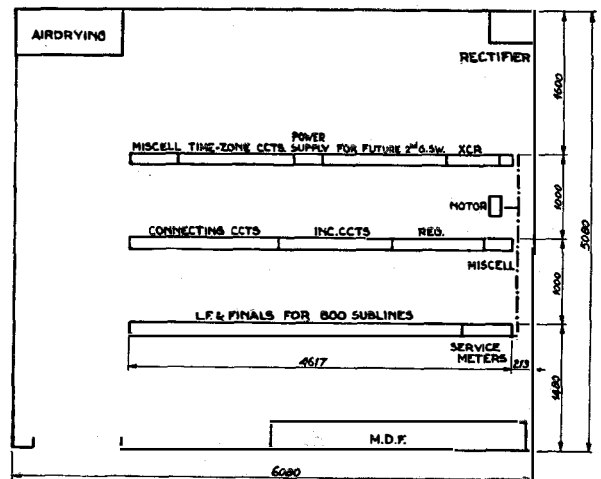

Fig. 9—Floor plan of the automatic switch room of the Warmond exchange.

The dialling impulses are registered in the distant exchange and at the same time in a control circuit in the tertiary office. In case a local

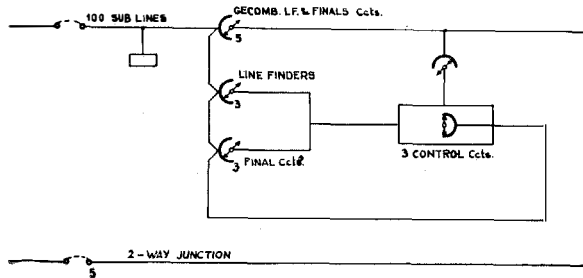

Fig. 10—Junction diagram of registerless end exchange.

number is required, the connection to the secondary office is dropped. The control circuit in the end office finds a local cord circuit and the line finder belonging to this cord circuit holds the calling subscriber line. The final, which is connected to the cord circuit, selects the called party; the combined line finders and final is released.

For outgoing calls to other exchanges only the combined line finder and final circuit are used. For this class of calls, the control circuit is required for the indication of the required zone.

Incoming calls from other offices are established by the combined line finder and final circuits, the control circuit indicating the required subscriber line.

In case all combined line finder and final

circuits are busy, a line finder of one of the cord circuits will hunt for the calling line and the dialling tone is given by the local circuit.

The equipment of the registerless offices is housed in a standardized type of building. Fig. 11 shows the floor plan of such a building. The switch room has a capacity for 300 subscriber lines. In addition to the automatic equipment, a wall-type main frame, a rectifier, and air-drying equipment have been provided. The power plant is of the same type as that of the small register exchanges. The ringing and tone machine is combined with the rack motor.

In The Hague district there are two registerless offices; namely, Zoeterwoude and Rijpwetering.

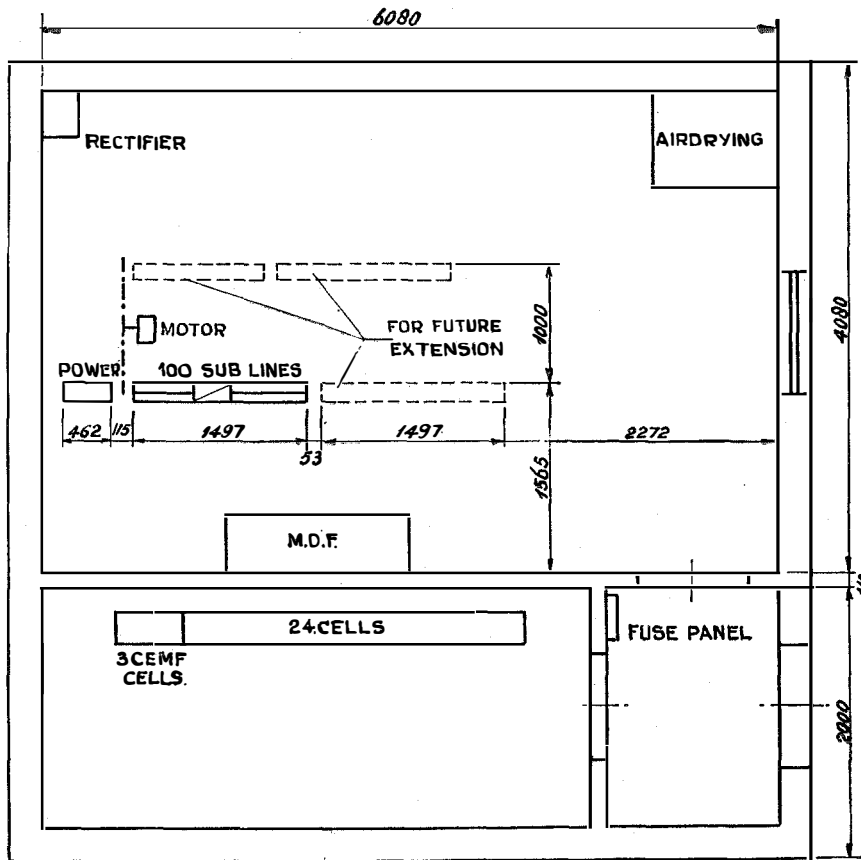

Fig. 11—Floor plan of a registerless end exchange.

9-A-1 Single-Channel Carrier Telephone System

By W. A. BRANDT, R. G. MADDOX, and A. C. PHILLIPS

*Wire Transmission Systems Division, Federal Telephone and Radio Corporation,
Newark, New Jersey*

THE newly developed 9-A-1 single-channel carrier telephone system described in this paper is designed primarily for application to open wire telephone lines, where it provides one additional talking circuit per pair of wires. Terminals are designed for interchangeable use at either end of a circuit, and provide for 2- or 4-wire termination by simple variations in strapping. Operation over average open-wire circuits up to 250 miles without a repeater is obtained by use of high loop gains, which are made possible by suitable filter characteristics. Repeater spacings are correspondingly long, but favorable economic considerations also permit use of this system on rather short facilities. The physical design is compact while permitting convenient access to parts requiring adjustment or maintenance.

Components are hermetically sealed by a new method which provides units of reduced size with novel glass-sealed terminals.

. . .

The 9-A-1 single-channel carrier telephone system is characterized by several new features which are largely the outcome of wartime acceleration of design and technique. It provides, per pair of wires, one additional talking circuit of a quality suitable for high-grade long-haul circuits, but of a design economical enough for use on relatively short lines.

Heretofore, single-channel carrier telephone systems have fallen into two rather sharply defined categories. The first class meets the requirements for long-haul circuits; trunks suitable for built-up switched connections. In meeting these transmission quality requirements, elab-

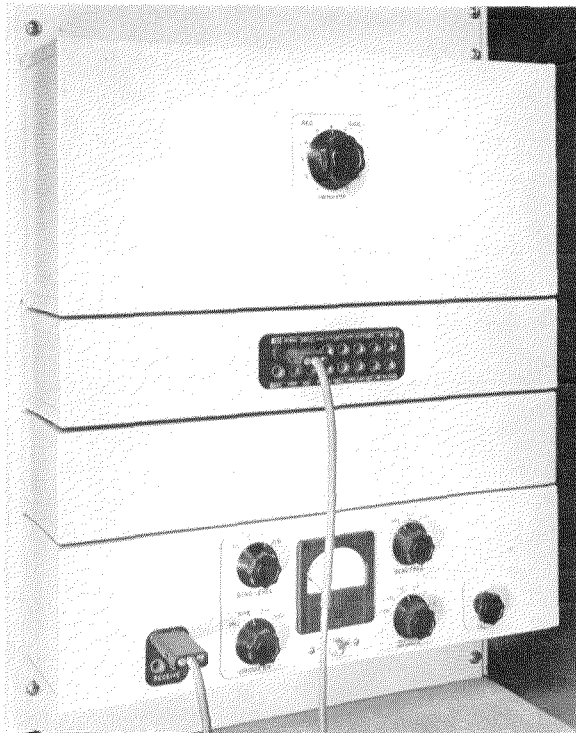

Fig. 1—Front view of carrier terminal. The top unit is the carrier channel terminal. Below are the line filter, power supply, and transmission-measuring set.

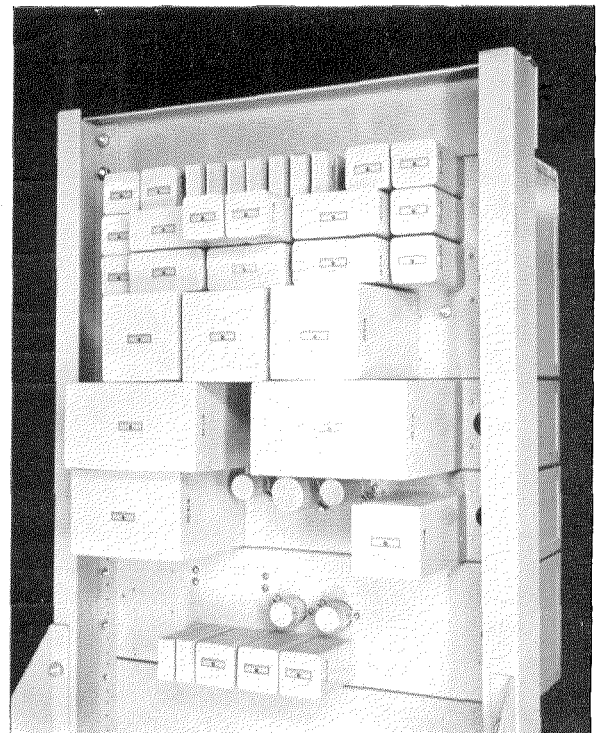

Fig. 2—Rear view of carrier terminal. Only inert units are mounted on the rear of the panels. These units are hermetically sealed.

orate circuits and rather large and costly components have heretofore been employed.

Secondly, there has been a considerable field of use for carrier telephone on shorter open-wire circuits ranging up to 200 miles, and on even longer circuits of private users, such as railroad and pipe-line companies, not serving the general public. Transmission requirements for a carrier system designed particularly for use on these circuits are, in most respects, less severe than those for a system designed to operate in long-haul service. In view of this fact, a number of low-priced, rather simple systems have been manufactured and widely used in spite of their often-limited performance.

The 9-A-1 single-channel carrier telephone system is applicable to either of the above situations. It is low in first cost and maintenance; hence, economic considerations often justify its use thereby avoiding the construction of additional short-haul circuits. Further, special consideration has been given to circuit design, quality of transmission, stability, and minimum maintenance to fulfill all conditions for a long-haul circuit. By utilizing for all components such as transformers and filters the newest techniques for magnetic-core materials, capacitors, and like elements, thus reducing the size of the components without impairing their quality, a reduction of the over-all size of the equipment has been made possible. The electrical circuits are designed to give high-grade performance and are easily adapted to a wide range of conditions. Careful mechanical design of the equipment facilitates maintenance and operation of the system.

1 Layout of Equipment

The equipment is designed for minimum weight and dimensions. Consideration has also been given to the general appearance which conforms with the trend in modern design. The equipment mounts on a standard 19-inch relay rack. Fig. 1 shows a front view and Fig. 2 a rear view of the carrier terminal. The 901-A carrier channel terminal occupies $8\frac{3}{4}$ inches of vertical rack space. The unit below this is the 901-A line filter which includes the necessary jacks to facilitate transmission measurements at different points in the circuit. This panel occu-

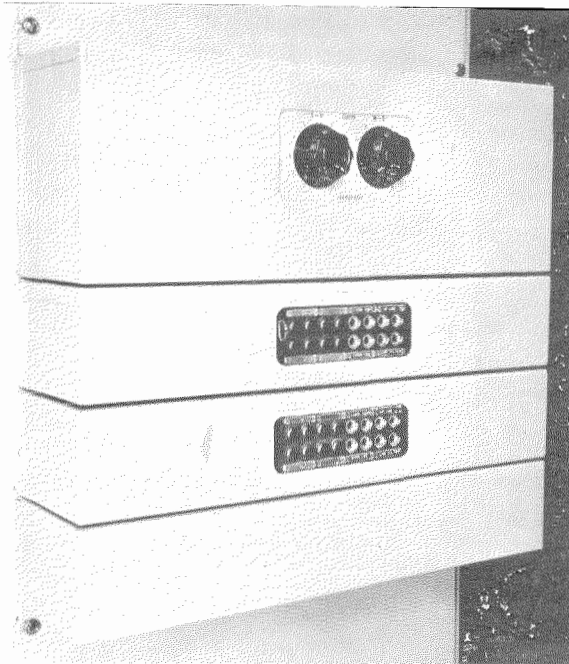

Fig. 3—Carrier repeater equipment comprises, from top down, carrier repeater, two line filters, and the power-supply unit.

pies $3\frac{1}{2}$ inches of vertical rack space. The 902-A power supply is mounted below the line filter and requires $3\frac{1}{2}$ inches of rack space. The total vertical rack space for a terminal is $15\frac{3}{4}$ inches. The 901-A transmission-measuring set, an optional piece of equipment, requires $5\frac{1}{4}$ inches of rack space.

Fig. 3 shows the carrier repeater equipment. The 901-A carrier repeater requires 7 inches of rack space. The two 901-A line filters are mounted below; each requires $3\frac{1}{2}$ inches of space. The 902-A power supply is mounted below the two line filters. The total vertical rack space required for the carrier repeater is $17\frac{1}{2}$ inches.

2 General Transmission Features

The system employs single-sideband, carrier-suppressed transmission using the lower sideband of 6.2 kilocycles per second in one direction (West to East) and the lower sideband of 10.3 kilocycles in the opposite direction (East to West). These frequency allocations are compatible with all standard single- and 3-channel carrier telephone systems.

Equalization is provided at the terminals and repeaters and is easily adjusted to compensate

for the slope characteristics of the wire lines employed. The over-all transmission characteristic of the system, including line and re-

3 Terminal

When operating with a 2-wire termination, the terminal has a nominal transmitting gain of 18 decibels and will operate at an output level on the line of +18 dbm¹ test power, relative to the transmitting switchboard. The receiving gain is 15 decibels from the line to the drop on a 2-wire basis. With a 4-wire termination, the maximum transmitting and receiving gains are about 21 and 19 decibels, respectively.

The transmitting gain and the receiving gain are adjustable by means of strap connections and, in addition, the receiving gain can be adjusted by means of a knob on the front of the carrier channel terminal, as can be seen in Fig. 1. This permits convenient adjustment of gain to compensate for day-to-day changes due to the effects of weather conditions on wire lines. The filters separating the transmitting side from the receiving side are so designed that the full transmitting and receiving gains can be used without danger of singing within the terminal and without interference from the transmitting side to

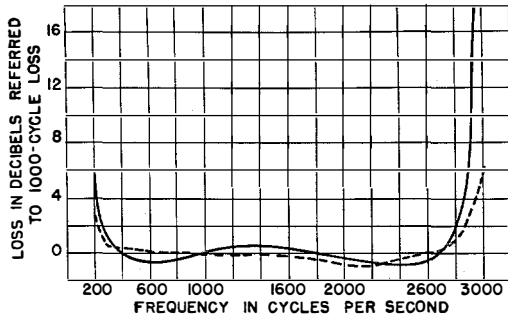

Fig. 4—Relative over-all loss-frequency characteristic of the 9-A-1 single-channel carrier telephone systems including one repeater. Solid line is for West-to-East transmission at a carrier frequency of 6.2 kilocycles. The dashed line is for East-to-West transmission at 10.3 kilocycles.

peaters, is essentially flat between 300 and 2700 cycles per second. This makes the system usable over long distances incorporating several intermediate repeaters without serious impairment of channel bandwidth. Fig. 4 shows the over-all loss-frequency characteristics of a 9-A-1 single-channel carrier telephone system.

¹ Levels expressed in dbm signify powers relative to a "zero level" of 1 milliwatt.

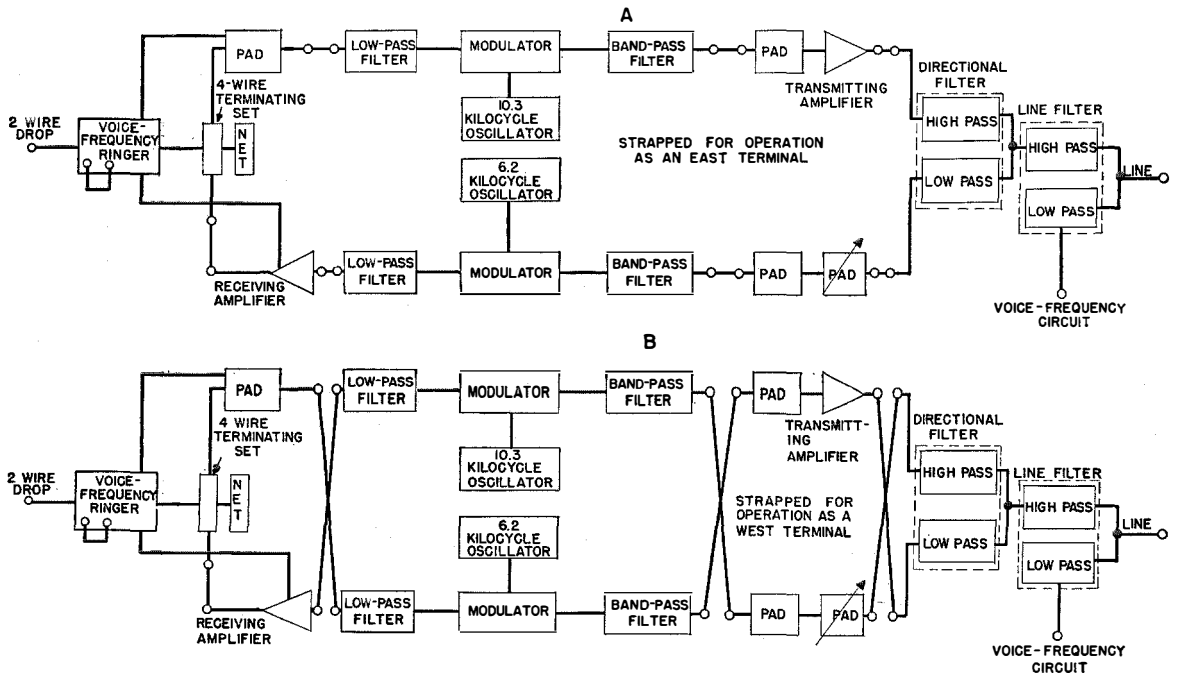

Fig. 5—Block diagrams showing interconnections of equipment to produce East or West terminals by means of strapping.

the receiving side for incoming levels as low as -18 dbm.

The 901-A carrier channel terminal employs copper-oxide rectifiers as balanced modulators and demodulators, and a single type of commercial vacuum tube for the oscillators and amplifiers. The carrier terminal includes facilities for voice-frequency ringing over the carrier channel when connected to magneto telephones or switchboards employing 20—50 cycle or direct-current ringing circuits. A convenient feature of the system is the possibility of using a terminal as a West or an East terminal by changing a few strap connections. As illustrated in Fig. 5, this is principally due to the use of bidirectional modulators. This interchangeability eliminates possible confusion in ordering and installing the equipment, and makes quick changeover possible to meet cases of emergency operation. Both 2-wire and 4-wire drop terminations are available by strap connections shown in Fig. 6.

4 Repeater

The carrier repeater provides a maximum gain of 40 decibels in each direction of transmission and will operate at a nominal output level of +18 dbm. The maximum gain in both directions can be used without danger of interference from one side to the other. The gains of the repeater are adjustable by means of strap connections and, in addition, they may be adjusted by knobs on the front of the carrier repeater, as can be seen in Fig. 3. This permits convenient compensation for variations in wire-line losses due to weather conditions.

5 Range

The range over which satisfactory transmission can be obtained with the 9-A-1 single-channel carrier telephone system depends largely on the type of wire line and amount of incidental cable. Under average noise and cross-talk conditions, the system will operate under all weather conditions over a range of about 250 miles without a repeater on lines constructed with copper wire 0.128 inch in diameter. Table I gives corresponding distances for other kinds of facilities. An average amount of incidental cable has been assumed. A longer circuit can be obtained by the

use of repeaters and, for the type of line mentioned above, approximately 450 miles with one repeater and about 1000 miles with repeaters in

TABLE I
MAXIMUM LENGTHS FOR NONREPEATERED SYSTEM

Diameter in Inches	Type of Open Wire		Length in Miles
	Material		
0.080	copper		160
0.104	copper		210
0.128	copper		250
0.165	copper		300
0.080	copper-steel, 40 percent conductivity		120
0.104	copper-steel, 40 percent conductivity		175
0.128	copper-steel, 40 percent conductivity		225

Note: Distances are approximate, including allowances for moderate lengths of incidental nonloaded cable.

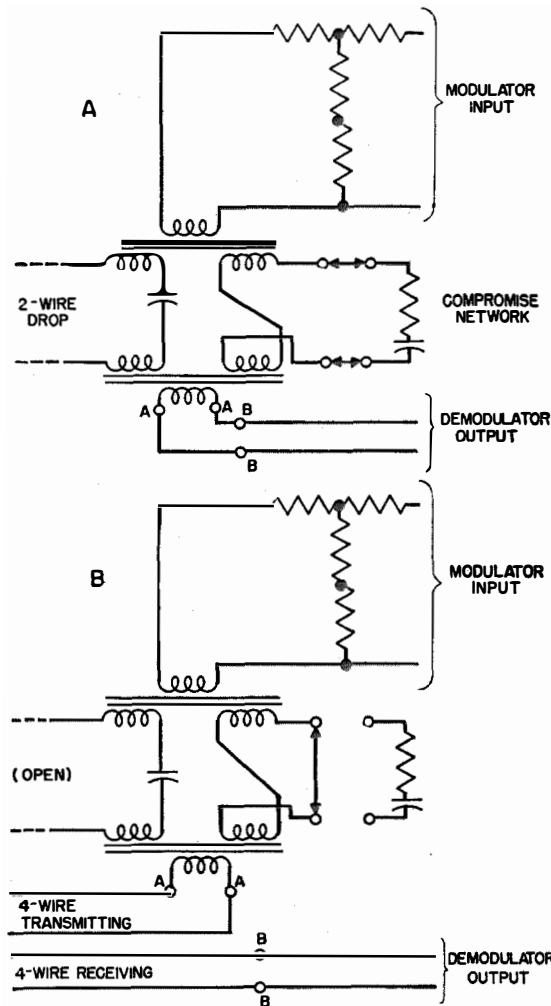

Fig. 6—Hybrid circuit arranged for 2-wire termination at A, and for 4-wire termination at B.

tandem can be spanned; in the latter case some reduction in the length of line sections is generally required.

However, as the design of the filter permits simultaneous use of maximum transmitting and receiving gains, it would be possible, under ideal line conditions, to obtain a channel equivalent of 6 decibels over a line section with a maximum attenuation of 39 decibels in the range of frequencies employed. This provides a reserve of some advantage for dealing with unusual applications.

6 Power Requirements

The equipment has been designed to operate from alternating-current mains or from 24-volt and 130-volt office batteries. The power require-

ments of the various units are given in Table II.

For use with alternating current, a separate power supply unit is provided. It is mounted on a standard 19-inch panel and requires 3½ inches

TABLE II
POWER REQUIREMENTS

Equipment	Heaters (Alternating or Direct Current)		Plate Supply (Direct Current)		Signalling (Direct Current)		Power Drawn from Alternating-Current Mains Watts
	Volts	Amperes	Volts	Amperes	Volts	Amperes	
Carrier Channel Terminal	24	0.6	130	0.090	24	0.010	30
Carrier Repeater	24	0.6	130	0.070	—	—	25
Transmission-Measuring Set	24	0.3	130	0.025	—	—	12

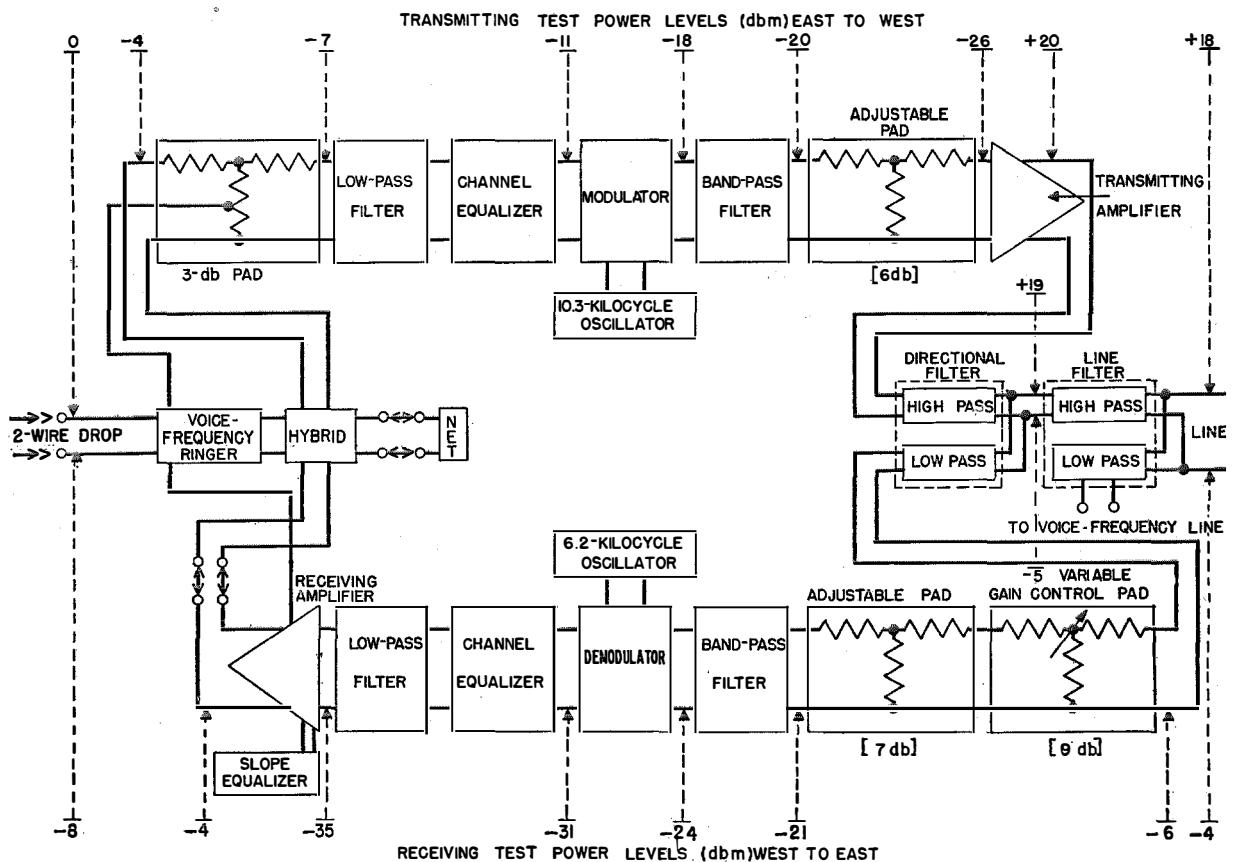

Fig. 7—Block diagram and power levels of single-channel terminal. The levels and pad losses (in brackets) are for an East terminal under the following assumed conditions:

Circuit Net Loss = 8 decibels
Transmitting Test Level = +18 dbm

Line Attenuation at 5.2 Kilocycles = 22.0 decibels.
Line Attenuation at 9.3 Kilocycles = 32.0 decibels.

Zero reference level (dbm) is 1 milliwatt.

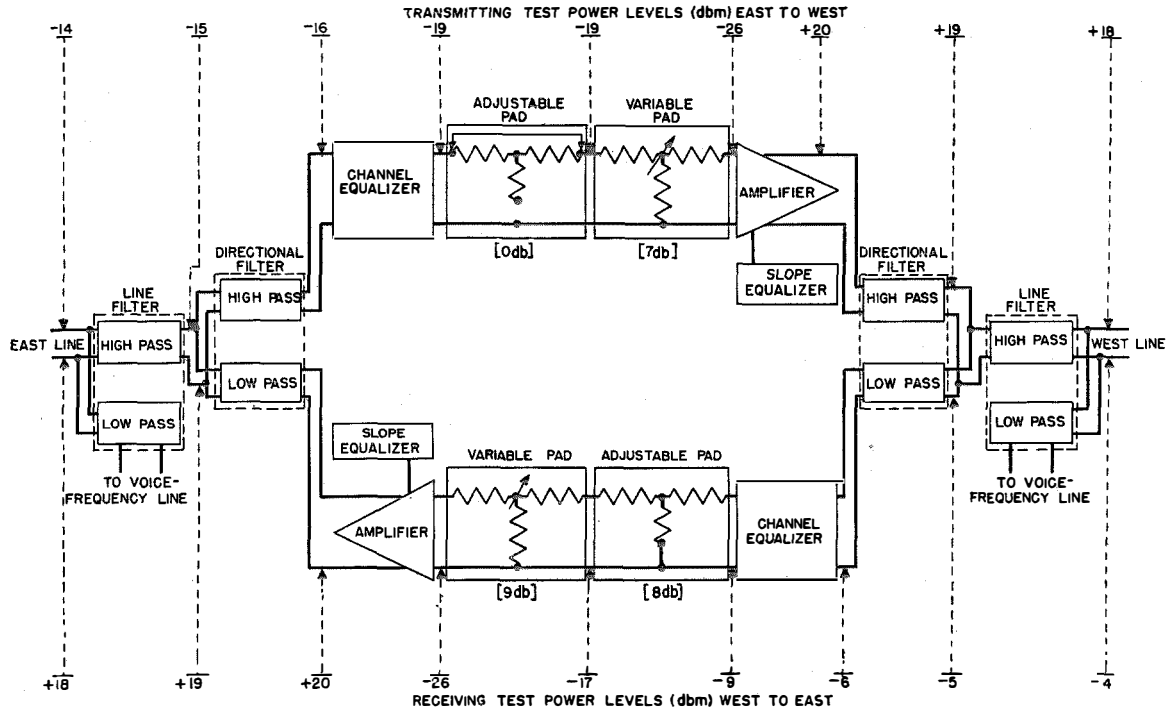

Fig. 8—Block diagram and power levels of single-channel carrier repeater. The levels and pad losses (in brackets) shown are for the following conditions: Line attenuation in both sections and net gain are each 32 decibels for East-West 9.3-kilocycle operation, and 22 decibels for West-East 5.2-kilocycle operation. Zero reference level (dbm) is 1 milliwatt.

of vertical space. It operates from a 50–60-cycle, 105–125/210–250-volt source. The power supply furnishes an alternating current of 1.5 amperes at 24 volts for filament heating. Selenium rectifiers supply direct current at 130 volts and 0.180 ampere for plate and at 24 volts for signalling. The power supply is adequate to operate 2 carrier terminals and a transmission-measuring set or 2 carrier repeaters. The plate loads are individually filtered to insure complete isolation between each load.

7 Circuit Description

7.1 TERMINAL

Fig. 7 shows a block schematic circuit of the carrier terminal. The voice frequencies coming from the switchboard pass the 4-wire terminating set, composed of a 2-coil hybrid arrangement, and then pass through a pad, low-pass filter, channel equalizer, and enter the modulator. The channel equalizer compensates for the frequency distortion caused by the combination of filters in the transmitting circuit.

The upper and lower sidebands generated in the modulator enter a band-pass filter, where the upper sideband is suppressed. The lower sideband is amplified in the transmitting amplifier. This amplifier has two stages and uses two tubes in parallel for the second stage, to secure the necessary undistorted output without requiring a different type of tube for higher power. Approximately 12 decibels of current and voltage feedback are also provided to further insure a uniform response-frequency characteristic and an undistorted output of +20 dbm at the amplifier with a 46-decibel gain. The sideband currents now pass through the directional filter, line filter, and out into the line.

At the opposite end of the line, the currents pass through the line filter, directional filter, variable pads, and band-pass filter in the receiving side of the terminal to the demodulator. The same unit serves as a modulator in an East terminal and as a demodulator in a West terminal, and vice versa.

The output of the demodulator passes through the channel equalizer which compensates for the distortion caused by the combination of filters

in the receiving circuit. The unwanted frequencies resulting from the demodulation process are suppressed by the low-pass filter and the voice-frequency currents are amplified in the receiving amplifier which has a fixed gain of 31 decibels. The response-frequency characteristic of this amplifier can be adjusted by a network in its negative-feedback circuit so that its gain slope compensates for the attenuation slope of the line. The maximum loop gain of the carrier terminal may be as high as 33 decibels when operating with a 2-wire voice-frequency termination; this loop gain is the sum of the transmitting and receiving net gains. The filter discrimination is sufficiently high to permit use of the entire loop gain when desirable.

The terminal is arranged so that either a 2-wire or a 4-wire voice-frequency termination can be obtained by strapping. In Fig. 6A, the 2-coil 4-wire terminating circuit is shown when operating with a 2-wire drop. It interconnects the modulator input and demodulator output with the 2-wire drop in a conventional manner, using a compromise network. It introduces about 4 decibels loss into both the transmitting and receiving branches.

In Fig. 6B, the 2-wire drop is left open and the network is short-circuited. This changes the hybrid-coil circuit into a link circuit with a loss of about 1 decibel. The straps connecting the A-A and B-B terminals in Fig. 6A are removed. Terminals A-A become the transmitting terminals and B-B the receiving terminals of a 4-wire circuit.

7.2 REPEATER

The carrier frequencies coming over the line from the terminal pass through the line filter, directional filter, channel equalizer, and into the amplifier and slope equalizer, as shown in Fig. 8. The channel equalizer compensates for the frequency distortion caused by the combination of filters in the circuit. The amplifier has two stages and uses two tubes in parallel for the second stage, to secure the necessary undistorted output without requiring a larger tube. Approximately 12 decibels of current and voltage feedback are also provided to give uniform response over the frequency range and an undistorted output of -20 dbm at the amplifier

with a 46-decibel gain. The slope equalizer, adjustable in steps of 1.5 decibels, is associated with the amplifier and compensates for the attenuation slope of the line. A 31-decibel strapping pad, adjustable in steps of 1 decibel, is provided for the initial adjustment of the repeater gain. A 10-decibel variable pad, adjustable by a knob in 1-decibel steps, is also provided for day-to-day changes resulting from the effect of weather conditions on the line. From the amplifier, the signal passes through a directional filter and a line filter to the wire line. The directional filters are designed to have sufficient discrimination to permit use of the full loop gain to meet unusual system layout requirements.

7.3 MODULATOR

Each carrier channel terminal contains two modulator units which are identical except for the frequency of the associated oscillators. The schematic circuit of a modulator and oscillator is shown in Fig. 9.

The modulator unit consists of copper-oxide rectifiers arranged in a balanced circuit providing suppressed-carrier transmission, occupying sidebands relative to carrier frequencies of 6.2 and 10.3 kilocycles. It is necessary to have a well-balanced modulator to obtain sufficient carrier suppression. Manufacturing variations in coil windings and copper-oxide rectifier elements may result in unbalance; this is corrected by inserting a selected resistor in series with one of the windings of the transformer T1.

The oscillator uses a single tube and transformer and is inherently stable, thus minimizing the need for synchronization while in operation. The oscillator is adjusted in the factory to the specified carrier frequency ± 2 cycles. The modulator coils, oscillator coil, and copper-oxide rectifiers are all hermetically sealed in a unit to insure long life and great stability. A fine frequency adjustment permits accurate synchronization between terminals during initial lineup. The output of the oscillator, which has a frequency of either 6.2 or 10.3 kilocycles, is supplied to the modulator circuit through transformer T3 at a level about 20 decibels above the normal level of the incoming voice-frequency currents. Transformer T3 serves also as the tuned oscillation transformer of the oscillator.

It is proposed to discuss the theory of operation of the modulator and demodulator by analyzing the relations between the voice and carrier currents existing at particular instants in the different branches of the circuit.

7.3.1 Operation of a Modulator

Consider a half cycle of a carrier wave at a certain moment in winding *f* (Fig. 9). Following the solid heavy arrows, it can be seen that this half cycle can flow through rectifier 3, winding *d*, resistance *R1*, and return through winding *b*. At the same time, the half cycle in winding *h* can flow through rectifier 2, winding *c*, resistor *R1*, and return through winding *a*. No currents flow at this time in windings *e* and *g*, as they are blocked by rectifiers 1 and 4. Because the two half cycles flow through the windings of *T1* and *T2* in opposite directions as indicated by the solid heavy arrows, their effects cancel, and no carrier appears in the external windings *i* and *j*. The carrier currents during this half cycle find rectifiers 2 and 3 to be equivalent to low resistances to the forward flow of carrier current, and rectifiers 1 and 4 to be equivalent to high resistances to the current applied in the reverse direction. As the voice currents are always considerably weaker than the carrier currents, they will not affect the equivalent resistances of the rectifiers,

which are always under control of the carrier currents.

As two rectifiers are thus conducting and two are virtually nonconducting at this time, a transmission path has been created through the modulator which permits currents in the voice-frequency winding *i* to cause currents to flow in the carrier-frequency winding *j* which may be traced as follows: Components of currents will flow as indicated by the solid light arrows starting in winding *a*, through winding *h*, rectifier 2, windings *c* and *d* in series; rectifier 3, winding *f*, and return through winding *b*. These component currents, unlike the carrier currents described above, flow in aiding directions in windings *c* and *d*, thereby inducing a current in the carrier-frequency winding *j*.

During the succeeding half cycle of the carrier current, the effect on the rectifiers is reversed, as may be seen by following the hollow heavy arrows in Fig. 9. Thus rectifiers 2 and 3 are blocked and rectifiers 1 and 4 are made conductive. This reverses the direction of the voice currents reaching transformer *T2* through the modulator, as is seen by following the dotted light arrows through rectifiers 1 and 4 and windings *d* and *c*. Thus the direction of the output current in winding *j* is reversed. This reversal occurs continually at carrier frequency.

This action of the modulator is thus the

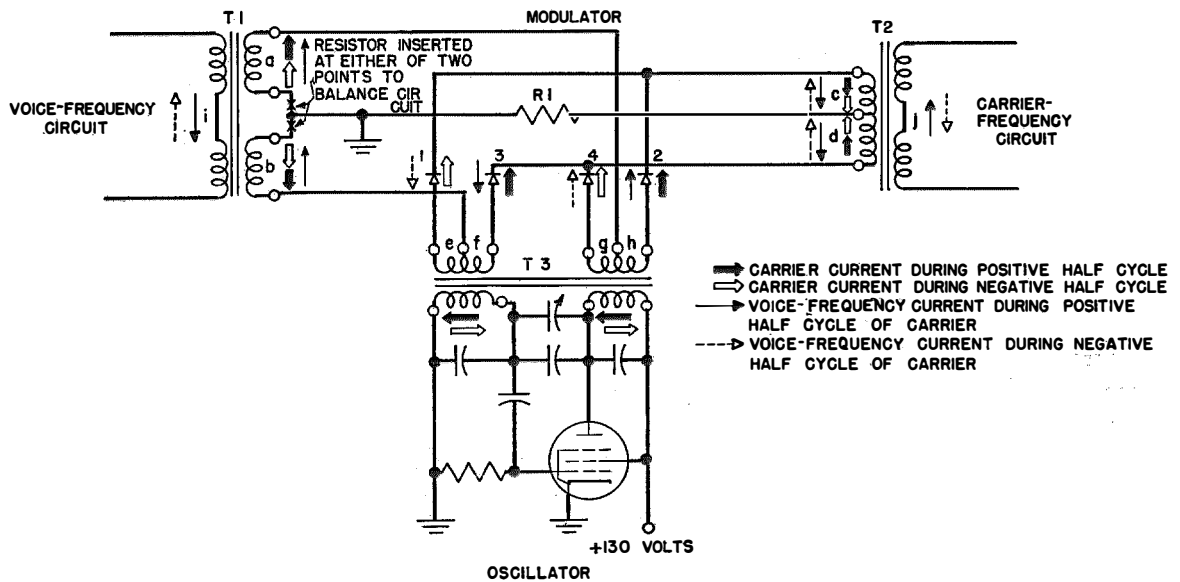

Fig. 9—Circuit of modulator and oscillator.

equivalent of a mechanical polarity-reversing switch operated at the carrier frequency. The modulator output current will have an envelope typical of the beat between two equal currents of different frequencies. In this case, these frequencies differ by twice the frequency of the

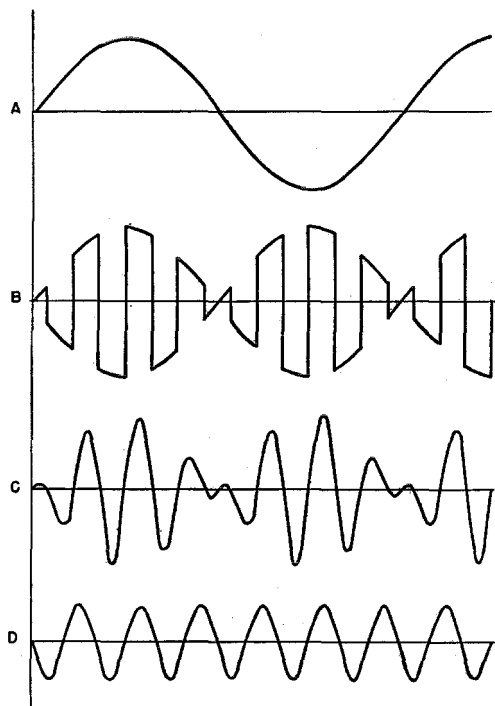

Fig. 10—Waveforms in the modulation process.

- A** is the voice-frequency current of 900 cycles.
B is the unfiltered output current from the modulator; 900 cycles reversed at a rate of 6.2 kilocycles.
C is the filtered double-sideband output current resulting from 5.3 and 7.1-kilocycle waves beating. The carrier is suppressed.
D is the lower 5.3-kilocycle sideband (side frequency) which is actually used.

modulating voice current. One frequency will thus lie above the carrier and one below, each spaced from the carrier frequency by an amount equal to the modulating frequency. No current of the frequency of the carrier oscillator is present in the output as it has been suppressed as described.

When a band of voice frequencies is impressed on the input circuit of the modulator, two corresponding bands of frequencies will be produced, one above and one below the carrier frequency, which are the familiar upper and lower sidebands.

In single-sideband transmission, one of these sidebands is eliminated by a filter, so there will be impressed on the carrier line a group of currents, each of which has a frequency determined by one of the modulating voice frequencies. The wave forms in various stages of the modulation process are indicated in Fig. 10 assuming a voice current of a single frequency. The sharp corners of the wave *B*, caused by reversing voice-frequency wave *A* at carrier frequency, would be rounded off if the signal went through a band-pass filter transmitting both sidebands. As only the lower sideband is passed by the filter used, a steady single-frequency sideband current is produced as at *D*.

7.3.2 Operation as a Demodulator

The modulator circuit serves equally well as a demodulator. In this case also, the operation of the circuit may be considered as equivalent to a mechanical polarity-reversing switch operating at the frequency of the local carrier oscillator. The frequency of an incoming lower-sideband current differs from that of the carrier oscillator by an amount equal to the original modulating voice frequency. There will therefore be continually recurring moments when the incoming signal will be in temporary synchronism with the reversing action of the demodulator circuit, first in a positive sense and then in a negative sense.

At an instant during one such short interval assume that the currents from the oscillator are flowing in the direction of the solid heavy arrows in Fig. 9, and the currents from the received signal are in the direction of the solid light arrows. The currents of the incoming signal are in the same direction through windings *a* and *b*. During the next half cycle of both currents, the oscillator currents flow according to the hollow heavy arrows. The input signal will flow in the direction of the dotted light arrows in windings *j*, *c*, and *d*. Their path through the demodulator is traced as follows: Leaving winding *c* with the dotted light arrow, the currents pass through rectifier 1, which is now conductive, windings *e*, *b*, *a*, and *g*, rectifier 4, which is also conductive, and return to winding *d*. Note that the currents of the incoming signal flow in the same direction as before through windings *b* and *a*. Thus during this short interval, momentary direct current

flows in the direction of the light solid arrows in windings *b* and *a*.

Now let us examine what happens when the phase of the incoming signal has slipped back relative to the oscillator until it is again in synchronism, but in the opposite sense. That is, when the oscillator currents are as represented by the solid heavy arrows, the signal currents in windings *c* and *d* are flowing according to the dotted light arrows. In this case their path will be as follows: Leaving winding *c*, they pass through rectifier 2, windings *h*, *a*, *b*, and *f*, and rectifier 3, all in a direction against the solid light arrow, returning to winding *d*. Note that the direction of the current in windings *a* and *b* is now contrary to the solid light arrows. On the next half cycle, the oscillator currents follow the hollow heavy arrows and the signal currents leave winding *d* in the direction of the solid light arrow, pass through rectifier 4, windings *g*, *a*, *b*, and *e*, and rectifier 1, all in the direction against the light arrows, and return to winding *c*. Note that these currents again flow through windings *a* and *b* contrary to the solid light arrows. Thus the momentary direct current in windings *a* and *b* has reversed when the signal and oscillator currents are in this opposite phase.

The reversal in relative phase between the incoming signal and the oscillator takes place at the same rate as the difference between the signal and the local carrier frequencies which in turn equals the frequency of the original voice frequency. The momentary direct currents in *a* and *b* therefore reverse at this rate, thus recreating the original modulating voice frequency in the winding *i*. The wave forms at various stages of the demodulation process are illustrated in Fig. 11. The incoming signal *A* is reversed at the reversal times of the demodulator *B*, producing "rectified" currents *C* in windings *a*, *b*, and *i*. The signal *C* contains many higher-frequency components, but these are eliminated when the signal passes through the low-pass filter following the demodulator, resulting in the smoothed-out voice-frequency wave, as at *D*. Note that at the points where *D* crosses the zero axis the positive and negative pulses are equal, producing a net direct current of zero value. This corresponds to the time intervals when the signal and the oscillator currents are 90 degrees out of phase.

If the oscillator of the demodulator is a few cycles per second out of synchronism with the transmitting oscillator, the demodulated currents will differ from the original frequencies by the same amount. Experience has shown that the impairment of speech is unimportant if this fre-

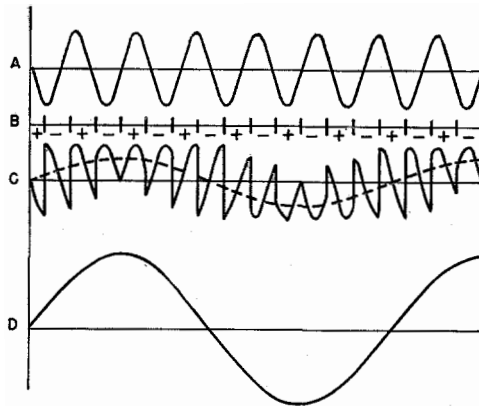

Fig. 11—Waveforms in the demodulation process.
A is the lower sideband (side frequency) of 5.3 kilocycles.
B is the carrier reversals at 6.2 kilocycles.
C is the unfiltered modulator output.
D is the voice-frequency output at 900 cycles from the low-pass filter after amplification.

quency shift is not more than 20 cycles. This effect must also be taken into account when operating a voice-frequency carrier telegraph system over the carrier telephone channel.

8 Voice-Frequency Ringer

The voice-frequency ringing equipment, which is included as a part of each terminal of the 9-A-1 system, has been considerably simplified by making use of an uninterrupted 2150-cycle tone in place of a 500-cycle or 1000-cycle tone interrupted at a low frequency. The signal receiving circuit is responsive only to signals within a narrow band at 2150-cycles, where the energy content of speech is small at the signal level normally employed. As the filter pass band tends to be wider at high input levels, an adjustable level control is provided so that the receiving circuit can be operated at the optimum level.

When a 20-cycle signal appears at the switchboard terminals, as in Fig. 12, the *C* relay operates, causing the *A* relay to operate, thus shifting the ringer circuit into the transmitting condition as an oscillator at a frequency of 2150 cycles.

It introduces an uninterrupted 2150-cycle signal into the transmitting branch of the carrier terminal at a level corresponding to the normal speech level at that point. This signal is transmitted to the distant terminal in the same manner as speech currents.

At the distant terminal, this signal reappears in the receiving circuits as a 2150-cycle tone. At the output of the receiving amplifier it is intercepted by the voice-frequency ringer. This ringer is normally in the receiving condition with its input circuit bridged across the primary of the receiving-amplifier output transformer, with tap adjustments.

The incoming preselected 2150-cycle tone is received and amplified; the selectivity of the circuit is improved by regeneration. A portion of this amplified signal is rectified by the selenium rectifier and applied to the grid circuit in a positive sense. If the signal persists, a fraction of a second later this will cause a relatively

large increase in the tube plate current, which operates relay *B*, which in turn opens the talking path and connects a source of low-frequency ringing current to the switchboard or 2-wire circuit.

If the terminal is used with a switchboard using direct-current signalling over a separate conductor, an outgoing ring will actuate the *A* relay directly. Incoming rings will operate relay *B* and in either case connect negative battery to the direct-current signal wire, signalling the switchboard.

9 Transmission-Measuring Set

For lining up and maintaining the 9-A-1 single-channel carrier telephone system, a relatively simple transmission-measuring set has been developed. This unit is shown in Fig. 1. It contains an oscillator which provides test signals at frequencies of 500, 1000, and 2000

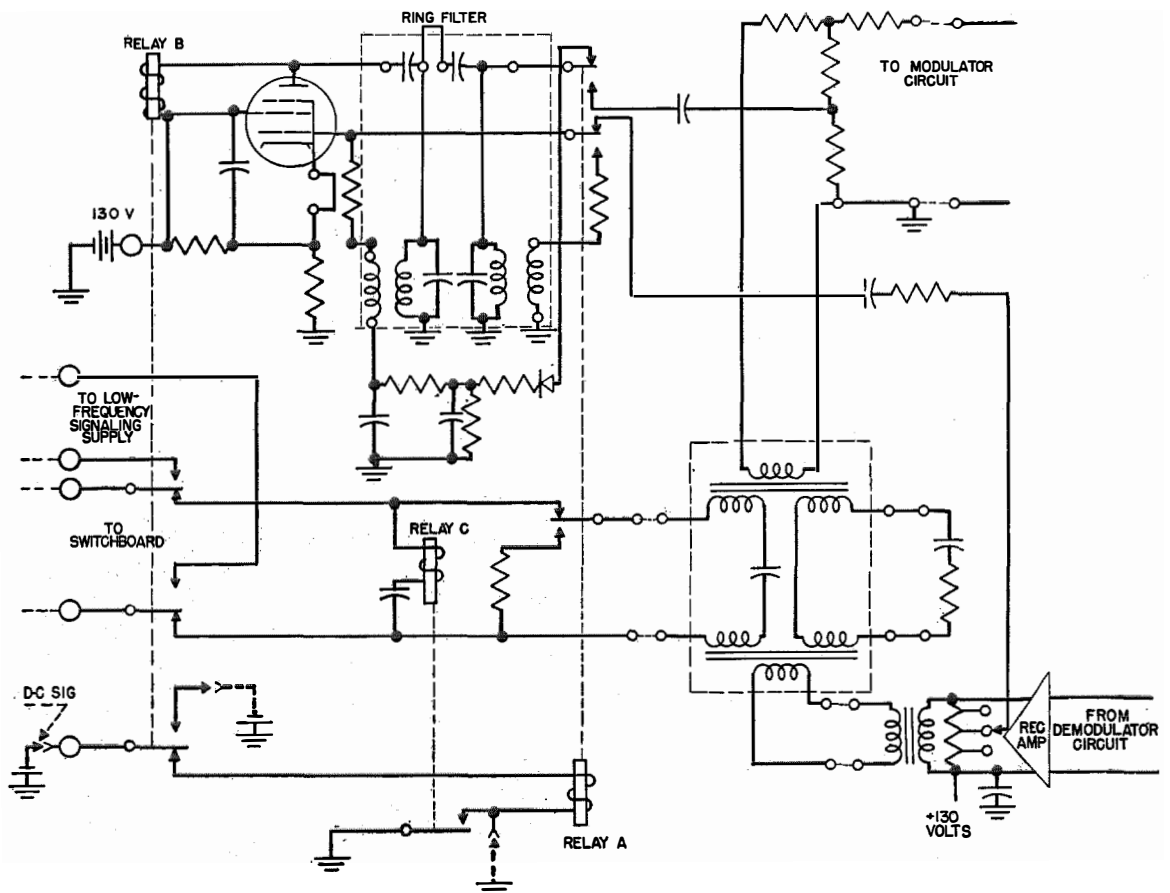

Fig. 12—Circuit of voice-frequency ringing equipment.

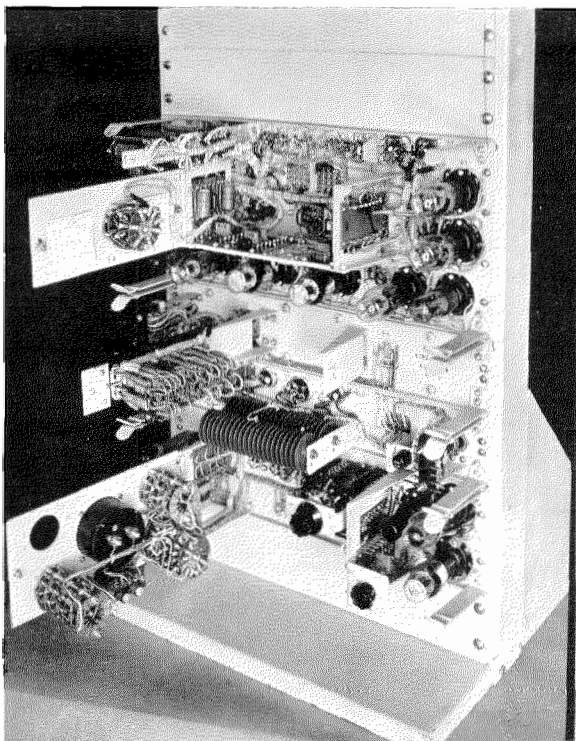

Fig. 13—Carrier terminal equipment with hinged panels opened to show accessibility of components.

cycles, with output levels adjustable from +10 dbm to -20 dbm, at a 600-ohm impedance.

The receiving portion of the set utilizes a rectifier-type meter and has a frequency range of 300 to 10000 cycles, at levels from -15 dbm to +25 dbm, with an accuracy of ± 0.25 decibel at most frequencies, and has an input impedance of 5000 ohms for measuring levels and 600 ohms for terminating measurements.

It requires 24-volt and 130-volt power which it normally obtains from the power supply associated with the terminal.

10 Maintenance

Although the equipment units have been designed compactly, every possible consideration was given to make all the parts which require adjustment or maintenance conveniently accessible. All tubes, wiring, and resistive components which may require maintenance are arranged conveniently on the front side of the panel. "Swing-out" panels are employed to mount gain controls, jacks, and meters. Fig. 13 shows the carrier terminal equipment with all dust

covers removed and the "swing-out" panels open for accessibility. This method tends to reduce the size of the equipment and yet provides adequate room for routine tests and maintenance. A removable dust cover encloses all apparatus on the front side of the panel presenting a neat appearance. Only inert apparatus components such as filters, transformers, and condensers are mounted on the rear of the panel. The line-filter panels which are supplied at the terminal and repeater locations, each contain the necessary jacks for making routine transmission tests on the carrier system. This avoids the necessity of separate jack facilities at a test board.

II Components

Emphasis was placed on making the components small and compact without sacrificing quality. This was achieved by using the newest techniques in designing iron cores and capacitors. Careful mechanical design has been followed, insuring long life against vibration. All transformers, filters, capacitors, and similar components have been hermetically sealed. This is done by using glass-sealed terminals, and by solder-sealing the covers on the housings. The components shown in Fig. 14, incorporating these features, illustrate the compactness of the terminal arrangements and the use of welded mounting bolts. The method used was developed to meet the urgent requirements of the armed forces for apparatus which would continue to operate under tropical-jungle humidity conditions. In achieving mass production, methods

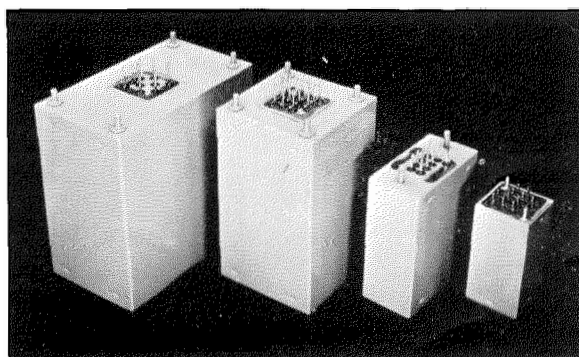

Fig. 14—Hermetically sealed components illustrating the compact arrangement of glass-sealed terminals.

and designs were developed which are now economically feasible for commercial use.

12 Special Applications

Two 9-A-1 single-channel carrier telephone systems can be applied to a suitable radio relay link capable of transmitting audio frequencies up to 10000 cycles with a reasonably flat characteristic. This will provide two speech channels in addition to the original channel.

As such a link is the equivalent of a 4-wire circuit providing simultaneous transmission paths in both directions, two carrier telephone terminals may be interstrapped as shown in Fig. 15, thus becoming a terminus, which employs both carrier frequencies in each direction over the radio circuit. The required interstrapping is readily accomplished by utilizing the same terminals provided for strapping the equipment to produce an East or a West terminal.

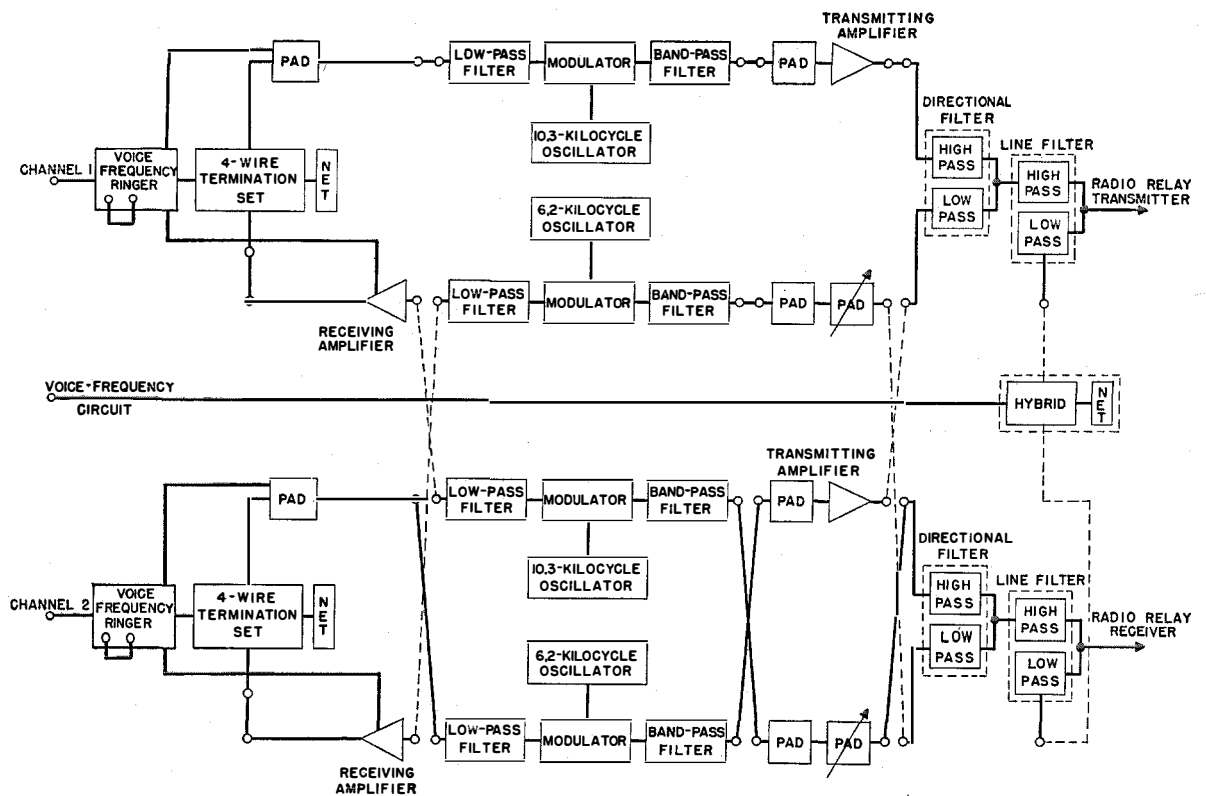

Fig. 15—Block diagram of 4-wire radio operation of two single-channel carrier terminals.

Pre-Heating by High-Frequency Currents*

By A. J. MADDOCK, M.Sc., F.Inst.P., M.I.E.E.

Standard Telephones & Cables, Ltd., London, England

PRE-HEATING of plastic preforms permits thicker sections to be moulded, a reduction in curing time, easy flow of moulding material around inserts, reduced shrinkage, more uniform and stronger products, and less wear on the moulds. Dielectric loss in the preform is the basis of high-frequency heating. A 2.5-kilowatt generator is capable of heating about 5 pounds of plastic material at a time.

The preforms may be arranged on a metallic sheet which is slipped into the high-frequency equipment and serves as the lower electrode. Specially shaped electrodes may be used for the rapid loading of multi-impression moulds. An air-gap between the material and upper electrode requires a higher output voltage but permits a fixed upper electrode, room for expansion of the material, and the ready escape of vapours. The variation of heating time with thickness and with different types of phenolic thermosetting materials is discussed.

. . .

Sufficient preliminary work has now been carried out to show that dielectric heating provides a powerful process for numerous branches of industry and confers properties not obtainable by any other known method of heating. Many advantages arise from its use in the plastics industry for pre-heating moulding materials, and different manufacturers are likely to place these advantages in differing order of merit according to the particular moulding processes involved in their products. It must be emphasized, however, that high-frequency heating is not a universal *sine qua non* and there are many instances where its use would definitely be of no advantage.

Pre-heating by high-frequency currents produces material, prior to moulding, which is:

- a. Uniformly heated throughout its volume.
- b. Already plastic and near to the "curing" temperature.

Resulting from these properties the following advantages of this type of heating may be listed:

- a. Increase in the thickness, hence volume and weight, of final product which can be moulded.
- b. Uniform and controllable conditions giving a product fully "cured" throughout, even in thick sections.
- c. Reduced "curing" time—to one-third or one-quarter of normal times—leading to a reduction of overall time-cycle where the "curing" time represents the major part of the cycle.
- d. Easy flow around inserts. This makes possible the use of reduced pressures—often to half that normally used.
- e. Reduced shrinkage of final moulding. Permits closer tolerances to be obtained and allows inserts, screwed directly into a moulding, to be easily withdrawn.
- f. The moulded products are consistently uniform.
- g. Increased mechanical strength of moulded product.
- h. Reduced wear on moulds.

On the equipment side, the products of reputable firms have now taken on a form suited to the needs of industry, enabling them to be operated by unskilled personnel and yet capable of dealing with a multiplicity of jobs. In the author's opinion the electrode system, within which the heating takes place, should be designed by the manufacturer of the generating equipment in order to obtain the fullest advantages and most efficient operation; whether the electrodes are an integral part of the generator unit or are located separately is a matter to be determined for each broad class of work. Generally, for pre-heating thermosetting resins in pellet or powder state, the complete equipment can form one unit, and it is with this class of work that these notes are concerned.

* Reprinted from *Plastics* (England), v. 9, pp. 443-449; September, 1945.

1 Equipment Design

Examples of two types of equipment are shown in Figs. 1 and 2, the former having an output power of 2.5 kilowatts, capable of heating up to 5 pounds of material, and the latter an output of 1 kilowatt suitable for loads up to 2 pounds in weight. As it is important for each load to attain the same temperature, the pre-heating is carried out on a constant-power and constant-time basis. Once set up for a given job, therefore, the operator has only to press a button at the commencement of each heating operation and the power is automatically switched off at the appropriate time. This not only leads to accurate and repeatable results, but makes the operation as simple as possible. In nearly all cases unskilled personnel will operate the equipment so that preliminary adjusting devices such as voltage control, time setting, etc., should be inside the equipment and not accessible to the operator.

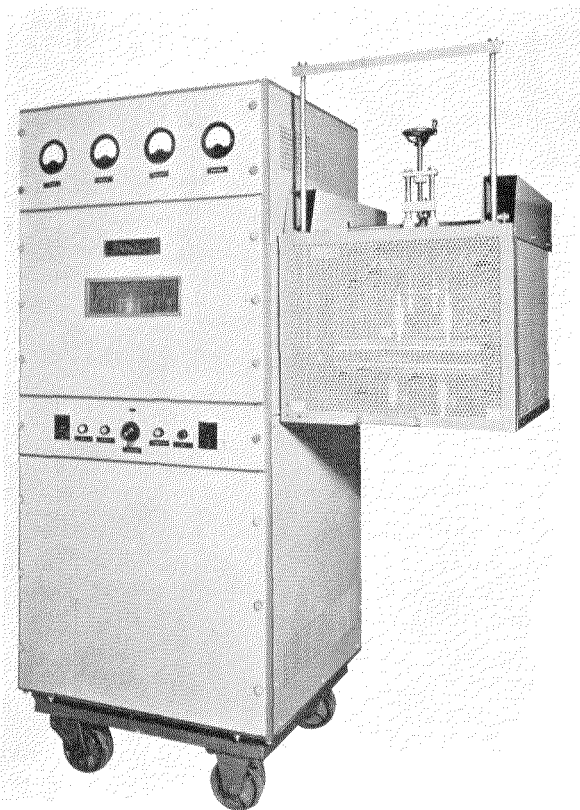

Fig. 1—2.5-kilowatt dielectric heating equipment. Electrode system particularly adapted for the plastics industry. Will heat up to 5 pounds of material.

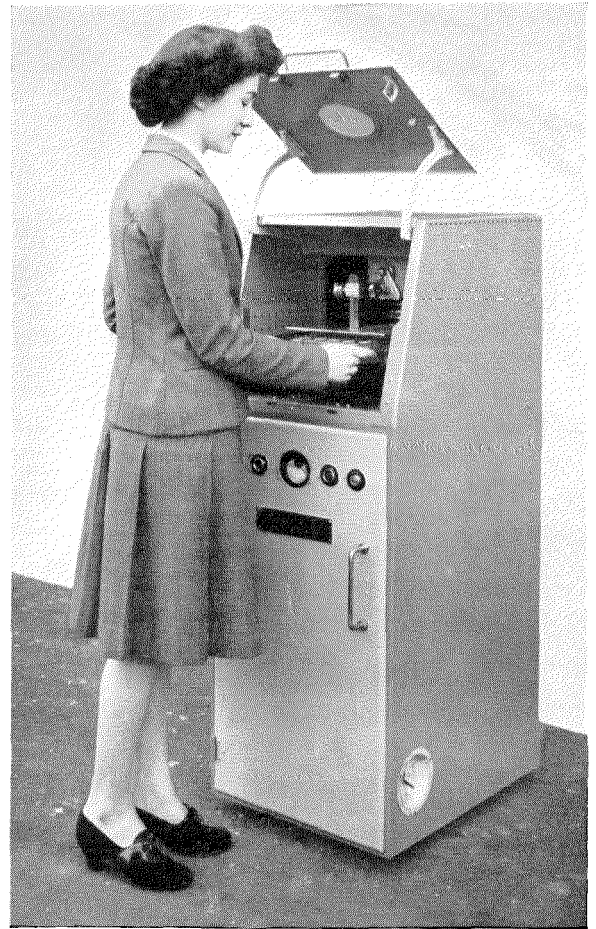

Fig. 2—1-kilowatt dielectric heating equipment. Only 18 inches wide, it is of convenient size for crowded moulding shops. Up to 2 pounds of material may be heated at once at a rate of 1 pound per minute.

With the electrode system supplied as part of the unit, very complete screening can be effected. Not only does this provide the necessary safeguard for the operators, but also ensures that interference caused by radiation of electromagnetic waves is reduced to a minimum. Provision of a filter in the mains-input leads prevents similar occurrence due to radio-frequency energy fed into the mains supply.

As a multiplicity of shapes and weights of load has to be dealt with, it is an advantage for the electrode system supplied to be adjustable both in separation and area of the plates. Once set for a job, the electrodes may remain fixed in position, in which case the work is loaded in on trays. On the other hand, it may be more convenient for the operator to load the work directly

on to the lower electrode, in which case adequate room for handling the work between the plates is necessary; this can be provided by making the top electrode automatically move away from the lower as the door of the electrode cage is opened.¹ The electrode system shown in Fig. 1 is of the latter type; adjustment for loads up to 3 inches thick is possible by means of the hand-wheel on the top of the cage, in addition to which the top electrode rises 3 inches when the door is opened. A close-up of the system with the cage door open is given in Fig. 3 which illustrates the ready access and free working space obtained. The electrodes should be of robust construction and be so finished that the plastic material does not stick to them.

2 Composition of Load and Methods of Loading

The simplest load to handle is that made up of compressed preforms. The latter can either be loaded individually on to the lower electrode by the operator, as in Fig. 3, or on a metal tray, sliding in rails, which itself forms the bottom

¹ British patent application 15814/44.

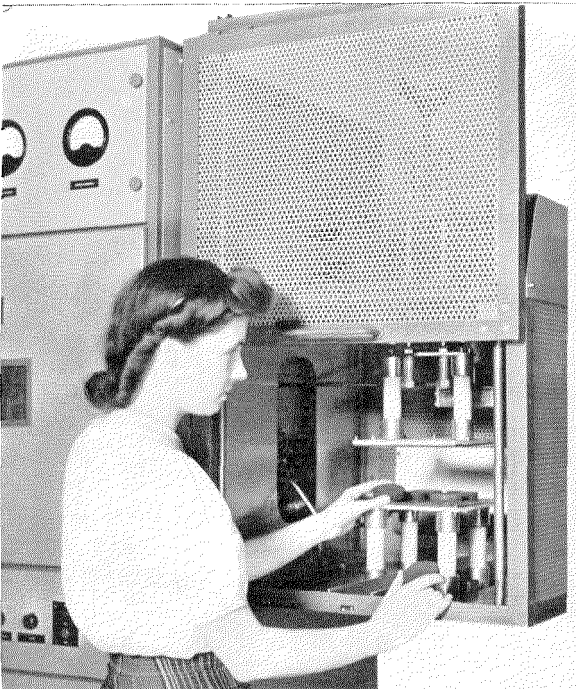

Fig. 3—Close-up view of fully automatic electrode system and cage. Note ready access and free working space.

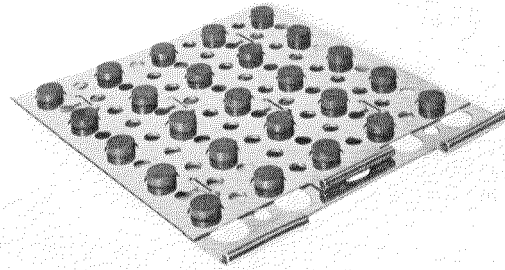

Fig. 4—Heating and loading tray for use with multi-impression moulds. The tray forms the lower electrode of the high-frequency system.

electrode. A quantity of pellets can be heated at the same time, but it is important to remember that, for a given set-up of the equipment, i.e., voltage and time cycle, each part of the load must have the same thickness, otherwise the thinner parts will not heat up so rapidly; this can be appreciated after a study of Section 3 following.

Multi-impression moulds can be catered for by using a tray of the type shown in Fig. 4, which is actually one for 25 impressions. The tray resembles the wooden loading trays commonly used in moulding shops, but is made of metal and forms both the lower electrode for the high-frequency heating equipment, and also the loading device for the moulds. When the pellets are hot the whole tray is removed from the high-frequency equipment, placed over the moulds and the top sheet slid along, allowing the pellets to fall into the impressions. The top metal sheet, which holds the preforms in place, must occupy only a small fraction of the height of the pellets, and the holes in it must be of generous size, otherwise electrical shielding of the bottom, outer ring of the preform occurs, with the result that these parts attain a lower temperature than the remainder of the material.

When heating a number of preforms, and particularly as in such a tray-load as described above, it is very advisable, and almost essential, to have an air-gap between the top electrode and the top of the preforms. It would be impossible for the top electrode to touch all pellets equally, and thus uneven heating would occur, but with an air-gap it is possible to equalize the

voltage-gradient existing across the pellets to a more uniform degree, and hence for all pellets to attain the same temperature. The air-gap also permits the use of sliding trays with fixed top electrodes, allows the material to expand, permits the vapour to escape more readily, and prevents flashovers occurring down the pellets due to accumulation of moisture.

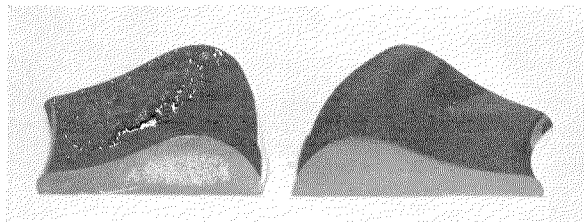

Fig. 5—Sections cut from lavatory seats moulded by normal method and with high-frequency pre-heating. Total weight of complete article 4 pounds. (Left) Normal method, 12 minutes cure; high percentage of rejects due to blistering. Density 1.26 grams per cubic centimeter (cavities filled with chalk for clarity). (Right) With high-frequency pre-heating, 6 minutes cure; solid core, fully cured, no blistering. Density 1.38 grams per cubic centimeter (Mouldings by Stadium Ltd.).

When heating powder, the air-gap confers similar advantages and, in fact, the author recommends an air-gap in nearly all cases. It is sometimes stated that this causes a waste of power, but this is erroneous. Output power is not wasted, for the air in the gap is not heated, but radio-frequency output voltage is wasted since a proportion of the voltage is dropped across the air-gap leaving a smaller voltage actually across the material being heated. This means a small increase in time required to attain a given temperature, but with a well-designed equipment with adequate output voltage, this is of small import. The addition of an air-gap is equivalent to adding an extra thickness to the material equal to the air-gap multiplied by the dielectric constant of the material.

It is quite feasible to pre-heat powdered resins up to a stage when the whole load coagulates into a plastic mass, so that it is unnecessary to make up compressed preforms; this is particularly useful where large blocks are concerned. If the temperature is not too high the blocks can be broken up by hand, if desired, for insertion in the moulds. On the other hand, if the powder must remain in a granular form so that it may be poured into deep cavities, then the heating

must be discontinued at a lower temperature, before coagulation sets in; e.g., for material having wood-flour filler, this occurs at about 70 degrees centigrade.

One of the difficulties of heating powder is in finding a suitable container which will not itself become excessively hot in the high-frequency field. This is a line in which more work must be done as the final answer has certainly not been reached. At present, containers of wood, cardboard, paper, glass, "mycalex," and mica-filled resins are used, but all have some disadvantage, either in heating-up or in absorbing moisture. It is to be hoped that the plastics industry will soon produce a material which does not soften or deteriorate until well above 150 degrees centigrade, and which has a loss factor not exceeding 0.008 (e.g., a power-factor not greater than 0.002 and a dielectric constant of about 4). Such a material would be suitable for containers and would also have many other applications in the radio industry, for which the only low-loss plastic materials available at present soften at too low a temperature. Of woods, we have found hemlock to be the best, as it does not heat up very rapidly and, fortunately, is often readily procurable from good quality packing-cases! The white-coloured wood of straight grain and free from resin should be chosen. From the heating point of view balsa is even better, but is too fibrous and loose-grained to use; many other, harder and close-grained woods are unsuitable, due to their rapid rate of heating. Several trays should be used in rotation to allow a period of cooling for each.

The temperature to which the material should be heated is a matter best determined by actual tests taken in conjunction with the moulding process. The temperature will be around 120–130 degrees centigrade, and curves already published for a 1-inch thick block of general purpose material² show that in going from 120 to 130 degrees centigrade, a reduction in curing time of 2.4 to 1.3 minutes is obtained, but that from 130 to 140 degrees centigrade, the gain is only from 1.3 to 1.0 minute, and beyond this temperature pre-curing sets in rapidly.

Transfer of material from the electrodes to the mould after pre-heating should be carried

² G. Dring, "High-Frequency Pre-heating," *Plastics* (England), v. 16, p. 13; January, 1944.

out as quickly as possible, and a general time to aim for is of the order of 15 seconds, but longer times can be tolerated, especially if the temperature of pre-heating is reduced a few degrees. It will be appreciated from these remarks that the dielectric heating equipment should be reasonably near to the press.

The outer layers of pellets pre-heated by dielectric heating are actually at a lower temperature than the interior, due to the cooling taking place to the air and to the electrodes. In general we consider this to be an advantage rather than a disadvantage, for it is these parts of the pellets which come into contact with the hot mould and so become heated first. Thus by the time the material is being forced into the mould the whole of the volume, including the outer layers, is at a reasonably uniform temperature.

Because moisture is driven off in the pre-heating process and because the moulded product is uniformly cured and without a porous interior (compare the densities of the mouldings in Fig. 5), a greater weight of powder must be allowed per article, the increase being of the order of 1 to 2 per cent. On the other hand, the weight allowed without pre-heating may have been on the generous side, the excess passing into the flash, but as the flow is now so much easier and rapid a reduction in weight may be possible. These are questions that can only be settled by consideration of individual jobs, but the matter is mentioned here since either case may arise.

3 Power Requirements and Times of Heating

On theoretical grounds it is easy to calculate the energy required to heat any mass of material through a given temperature rise when heat loss from the outer layers of the material is neglected.³ Thus to heat any material having a specific heat of 0.35 calorie/gram/degree centigrade (an average value for a phenolic resin with filler) through a temperature rise of 100 degrees centigrade (i.e., for a final temperature of about 120 degrees centigrade) requires a supply of

³For simple data charts enabling calculations to be made rapidly see: A. J. Maddock, "Calculations for Dielectric Heating by High-Frequency Current," *Electronic Engineering*, v. 17, pp. 635-639; August, 1945, and correction v. 18, p. xiii; February, 1946.

energy to it of 40 watt-hours per kilogram, or 18 watt-hours per pound of weight.

The power required, i.e., the rate at which energy is to be supplied, will depend, of course, on the time in which the temperature rise occurs; the product of power and time is equal to the energy. Thus, for the above material, if the time is to be 1 minute, the power will be 2.5 kilowatts

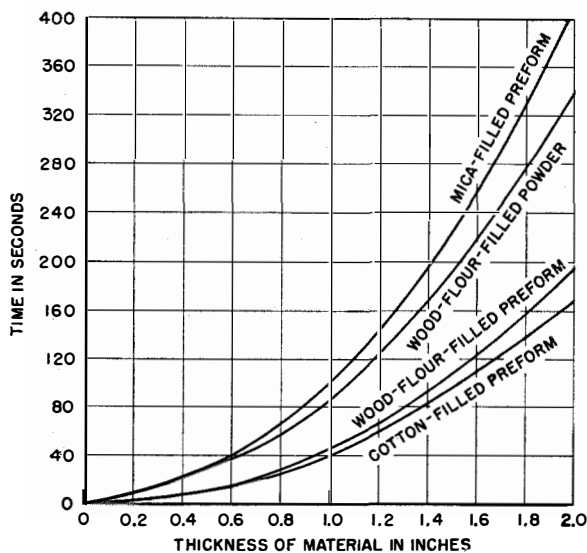

Fig. 6—Variation of heating time with thickness for different types of phenolic thermosetting materials.

per kilogram or 1.1 kilowatts per pound. For double the time, the power will be halved, etc. Whether an equipment can deliver energy at such a rate into a particular load is not determined by its total capacity rating in kilowatts, but by the voltage-gradient existing across the material being heated.

The output voltage of a high-frequency generating equipment depends to some extent on the load placed between the electrodes, but it is obvious that it will have an upper limit for each equipment. It follows then that for a fixed output voltage the time of heating will increase as the thickness of the load increases. Furthermore, the time is proportional to the square of the material thickness, if other factors remain constant, so that the power input to the material also falls off at the same rate. The time of heating does not depend on the area of the load but only on its thickness.

To illustrate these points, and to indicate the order of magnitude of time, Fig. 6 is appended;

the curves are all shown for an approximately fixed output voltage and a final temperature of 130 degrees centigrade, i.e., a rise of 110 degrees centigrade. The increase of time with the square of the thickness is apparent, and the curves illustrate also the difference in heating time between various grades of thermosetting resins.

As is to be expected, the mica-filled material heats at the slowest rate due to its low loss-factor, whilst a composition containing such a material as cotton, having a poorer loss-factor, heats most rapidly. The times are dependent, also, on the amount of moisture in the material; the greater

the moisture content, the more rapid the heating. This is one of the advantages of high-frequency pre-heating, as it helps to produce heated pre-forms of a more uniform moisture content, thus counteracting, to a considerable extent, the day-to-day variations which occur with atmospheric humidity. It will be noted that a material in powder form takes about twice as long to attain a given temperature as its counterpart in pelleted form. This is due to the large amount of air around the granules causing the voltage-gradient across the actual resin to be less than in the case of pellets.

Cathode-Excited Linear Amplifiers

By J. J. MULLER

Laboratoire Central de Télécommunications, Paris, France

CERTAIN properties of cathode-excited amplifiers are of great importance in high-frequency multiplex transmission. Neutralization of these amplifiers is considered in relation to power amplification, stability, and feedback. The use of neutralizing capacitances having values which differ from the internal capacitances of the vacuum tubes, in combination with appropriate reactances between the grids of symmetrical stages, permits control of power amplification, stability, and feedback. Some results obtained on a 60-kilowatt single-sideband amplifier are given.

• • •

The cathode-excited or inverted amplifier has found important applications in transmitters operating in the decametric, metric, and decimetric wavelength regions.¹⁻⁴ Compared to grid-excited amplifiers, cathode excitation offers, in particular, a lower residual capacitance, a generally higher output power, easier neutralization, and, under certain conditions, a negative feedback inherent to the circuit. These advantages have similarly encouraged its use in receiving circuits.⁵ Furthermore, high-frequency multiplex links offer an important new field of application for the inverted amplifier because they require distortion-free amplification of low-level complex signals originating in terminal equipments.

In high-frequency applications of these amplifiers, consideration must be given to neutralization for which two methods are commonly used.

In the first method, the grids are connected to a point having zero impedance to ground, and a

bridge of neutralizing capacitances equal to the plate-filament capacitances of the tubes is used. The properties of this circuit have been described by Strong.²

The second method of neutralization requires between the grids an inductance of a value that will compensate for the coupling between input and output circuits which results from the internal capacitances of the tubes. This method has been applied, in particular, to television equipment.³

The behavior of these two circuits is quite different. They may be considered as special forms of the more general case in which the neutralizing capacitors have values differing from the internal capacitances of the tubes, and in which an appropriate reactance is connected between the grids. Under these conditions, the value of neutralizing capacitance permits continuous variation of the power amplification, stability, and negative feedback.

1 Neutralization

The purpose of neutralization is to make the input and output circuits independent of each other with respect to reactive currents. The input current must be independent of the output voltage and reciprocally. In other words, if we consider the amplifier circuit as a passive network, the input and output circuits should be conjugated in the sense of Maxwell's reciprocity law. This condition is necessary to permit independent tuning of the input and output circuits, so that the variations in output voltage do not produce variations of phase angle of the input impedance, resulting in phase modulation.

This condition of independence between input and output circuits, which may be called the "neutralized condition," does not necessarily imply stability, because the suppression of coupling by capacitive currents between input and output circuits is not sufficient to remove the effect of the output voltage on the cathode-to-grid voltage. A second condition, distinct from

¹ L. W. Hayes and B. N. MacLarty, "The Empire Service Broadcasting Station at Daventry," *Journal of the Institution of Electrical Engineers*, v. II, pp. 321-357; 1939.

² C. E. Strong, "The Inverted Amplifier," *Electrical Communication*, v. 19, n. 3, pp. 32-36; 1941.

³ S. Mallein and G. Rabuteau, "L'Émetteur de télévision de la Tour Eiffel," *Revue des Communications Electriques*, v. 17, pp. 376-392; April, 1939.

⁴ N. D. Deviatkov, M. D. Gurivich, and N. K. Khokhlov, "A Metal Triode for Ultra-High-Frequency Operation," *Proceedings of the I.R.E.*, v. 32, pp. 253-256; May, 1944.

⁵ M. C. Jones, "Grounded-Grid Radio-Frequency Voltage Amplifiers," *Proceedings of the I.R.E.*, v. 32, pp. 423-429; July, 1944.

neutralization, must be met for complete stability.

In symmetrical or push-pull grid-excited amplifiers with grounded cathodes, as shown in Fig. 1, if the inductance of the leads is considered

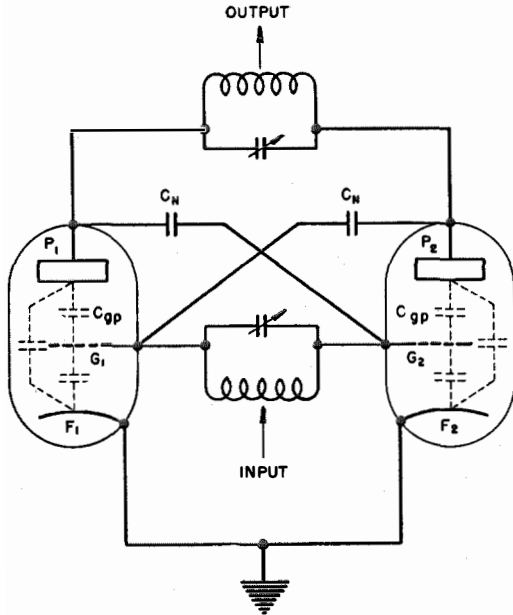

Fig. 1—Neutralization of a symmetrical grid-excited amplifier by cross-connected capacitors.

to be negligible at the operating frequencies, independence between the input and output circuits is generally obtained by cross-connecting the grids and plates through capacitors C_N having values equal to the internal grid-plate capacitances C_{gp} of the vacuum tubes. The requirements of stability and neutralization are fulfilled simultaneously because the input circuit is connected between the grids (in the case of a symmetrical stage) or between the cathode and grid (in a single-ended or asymmetrical amplifier.)

The same method of neutralization may be applied in symmetrical cathode-excited amplifiers where the grids are grounded and the lead inductances are considered to be negligible at the operating frequencies. The grids and cathodes are inverted and the neutralizing capacitors C_N have a value equal to the internal cathode-plate capacitance C_{fp} of the vacuum tubes as shown in Fig. 2.

If the grids are not at ground potential because the inductance of the leads is not negligible, coupling may exist between the input and output

circuits through the plate-grid capacitances, cathode-grid capacitances, and grid-to-grid inductance. One method of reducing this coupling is to insert between the grids² a series-tuned circuit which has zero reactance at the operating frequencies. This is shown in Fig. 3.

It is also possible to use neutralizing capacitors of values which differ from the internal capacitance of the tubes together with a reactance between the grids of symmetrical amplifiers.

Fig. 4 shows an arrangement of a symmetrical inverted amplifier using this method of neutralization. C_{fp} is the internal cathode-plate capacitance of the vacuum tube. P is the plate, G the control grid, and F the cathode. C_N are the neutralizing capacitors, the values of which are not equal to C_{fp} , and $2Z$ is a reactance between the grids which permits the desired independence of the input and output circuits to be achieved.

In such a symmetrical amplifier, calculations of the reactive currents to the cathodes show that, as far as coupling between input and output circuits is concerned, the circuit behaves as though the neutralizing capacitors were removed and the cathode-plate capacitance of each tube was equal to the difference between the real

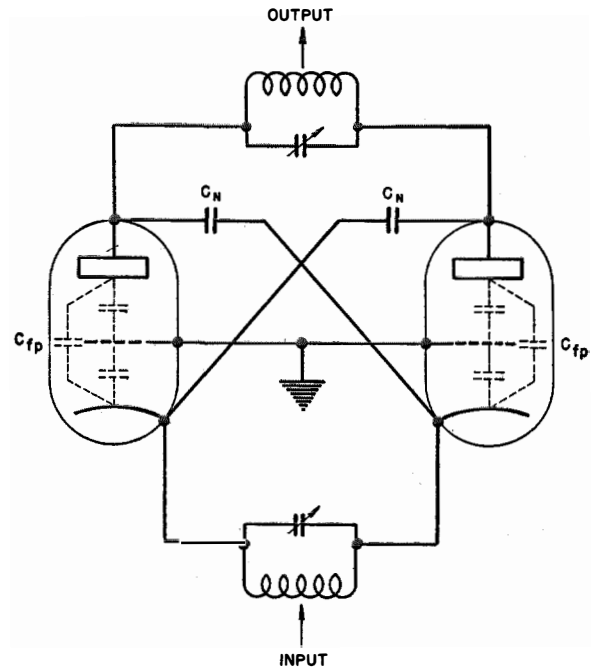

Fig. 2—Neutralization by cross-connected capacitors of a symmetrical cathode-excited amplifier with grounded grids.

value of the cathode-plate capacitance and the neutralizing capacitance, and also as though there existed between the two cathodes and between the two plates, two capacitances equal to C_N . This equivalent circuit is shown in Fig. 5.

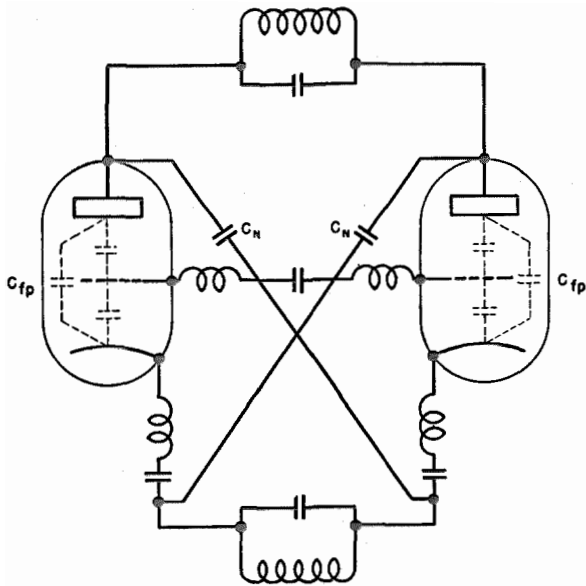

Fig. 3—Neutralization by cross-connected capacitors of a symmetrical cathode-excited amplifier with compensation of lead inductance.

The relation $C_{fp}' = C_{fp} - C_N$ is algebraically true, which means that if the neutralizing capacitance is greater than the cathode-plate capacitance, the circuit behaves as if an inductance were inserted between the cathode and plate.

Fig. 5 is identical in form to that for which Labin has specified the neutralized condition.³ This is obtained by making Z such that

$$Z = \frac{\gamma_1 \gamma_2}{\gamma_1 + \gamma_2 + \gamma_3'} \tag{1}$$

where

$$\left. \begin{aligned} \gamma_1 &= \frac{1}{j\omega C_{fp}'} \\ \gamma_2 &= \frac{1}{j\omega C_{gp}'} \\ \gamma_3 &= \frac{1}{j\omega C_{fg}'} \\ \gamma_3' &= \frac{1}{j\omega(C_{fp} - C_N)} = \frac{1}{j\omega C_{fp}'} \end{aligned} \right\} \tag{2}$$

These relations may be proved by calculating the total current through the capacitances connected to the cathode of one of the tubes.

Fig. 6 represents a general inverted amplifier with an impedance $2Z$ between its grids in accordance with (1). Assuming that, regardless of the value of C_N , Z will comply with (1) and (2), it will be shown that under these conditions the amplifier is neutralized.

Assume that symmetrical voltages are established. The voltages, with respect to ground, on the three electrodes of tube 1 are designated U_c , U_g , and U_p . Three currents flow from the filament F_1 through capacitances. One of these i_N is through the neutralizing capacitor to P_2 .

$$i_N = \frac{U_c + U_p}{\gamma_N}$$

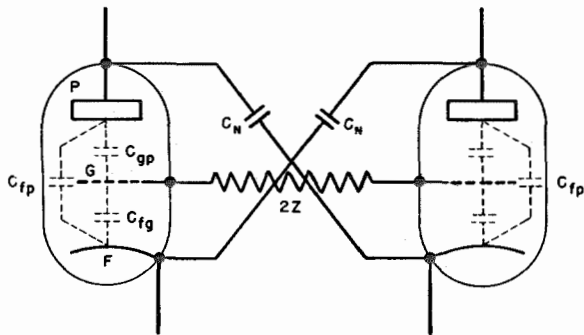

Fig. 4—Neutralization by cross-connected capacitors and a reactance between grids.

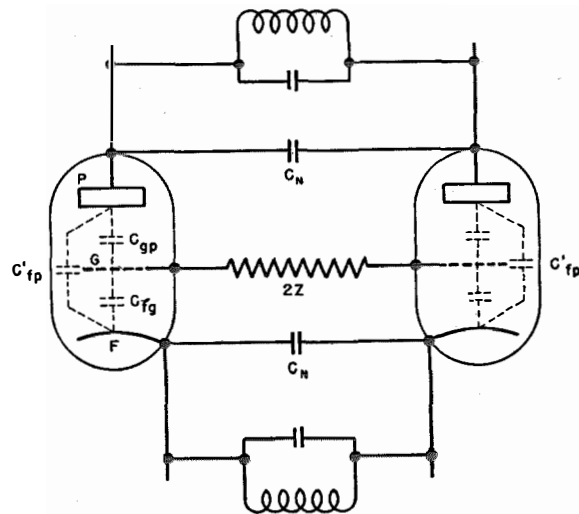

Fig. 5—Equivalent circuit of Fig. 4.

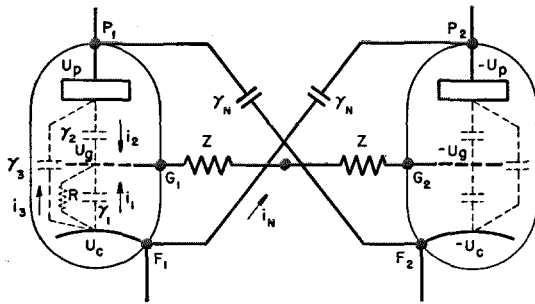

Fig. 6—Schematic arrangement of cathode-excited amplifier with cross-connected capacitors and a reactance between grids.

where

$$\gamma_N = \frac{1}{j\omega C_N} \tag{3}$$

The second i_3 is through the capacitance C_{fp} to P_1 .

$$i_3 = \frac{U_c - U_p}{\gamma_3}$$

The third i_1 is through the capacitance C_{fg} to G_1 .

$$i_1 = \frac{U_c - U_g}{\gamma_1}$$

U_g is a function of U_c and U_p because

$$U_g = (i_1 - i_2)Z,$$

and

$$i_1 = \frac{U_c - U_g}{\gamma_1},$$

$$i_2 = \frac{U_p - U_g}{\gamma_2},$$

hence

$$U_g \left(\frac{1}{Z} + \frac{1}{\gamma_1} + \frac{1}{\gamma_2} \right) = \frac{U_c}{\gamma_1} + \frac{U_p}{\gamma_2}$$

As Z is given by (1) and (2),

$$\frac{1}{Z} + \frac{1}{\gamma_1} + \frac{1}{\gamma_2} = -\frac{\gamma_3'}{\gamma_1 \gamma_2}$$

and

$$U_g = m_c U_c + m_p U_p, \tag{4}$$

where

$$\left. \begin{aligned} m_c &= \frac{\gamma_2}{\gamma_3'} = \frac{C_N - C_{fp}}{C_{gp}}, \\ m_p &= -\frac{\gamma_1}{\gamma_3'} = -\frac{C_N - C_{fp}}{C_{fg}}. \end{aligned} \right\} \tag{5}$$

If U_c and U_p are known, U_g may be determined by (4), which is a linear and homo-

geneous combination of U_c and U_p . With reference to (5), the current i_1 will be

$$i_1 = \frac{U_c(1 - m_c) - m_p U_p}{\gamma_1} = \frac{U_c}{\gamma_1} \left(1 + \frac{\gamma_2}{\gamma_3'} \right) + \frac{U_p}{\gamma_3'}$$

and the total current from the cathode will be

$$i_T = i_N + i_3 + i_1 = U_c \left[\frac{1}{\gamma_N} + \frac{1}{\gamma_3} + \frac{1}{\gamma_1} \left(1 + \frac{\gamma_2}{\gamma_3'} \right) \right] + U_p \left(\frac{1}{\gamma_N} - \frac{1}{\gamma_3} + \frac{1}{\gamma_3'} \right).$$

The relations (2) and (3) being established by definition, the coefficient of U_p is zero and the capacitive current from the cathode is independent of the voltage across the output circuit. This result is true only if the conditions of Fig. 6 are completely fulfilled. The neutralizing capacitors must be connected directly to the cathode, and for very high frequencies, the inductance of this connection must be considered.

Further, the grid voltage should not rise to abnormal values, for if grid current flows, a grid resistance R will appear in parallel to γ_1 (Fig. 6). This resistance should be large with respect to the reactance γ_1 , or the balance of the reactance bridge will be upset and variations of R will produce phase modulation.

In conclusion, for each value of neutralizing capacitance, there is a value of Z which satisfies the condition of neutralization.

If the neutralizing capacitances C_N are smaller than the cathode-plate capacitances C_{fp} , it is evident from (1) that the impedance Z must have an inductive reactance. If C_N is larger than the cathode-plate capacitance but smaller than

$$C_{fp} + \frac{C_{fg} C_{gp}}{C_{fg} + C_{gp}},$$

the impedance Z must have a capacitive reactance. If C_N is greater than the immediately preceding value, the impedance Z should, again, be inductive: Such values of C_N have not so far been used in practice.

The reactance of Z may be supplied by a series resonant circuit or some other combination of appropriate reactances or lines which will present the desired capacitive or inductive characteristics.

2 Power Amplification

An important property of the neutralizing method just described is that power amplification is a function of neutralizing capacitance while the independence of cathode and plate circuits from the viewpoint of reactive currents may be obtained with any value of neutralizing capacitance.

It is necessary to operate power-amplifier tubes under conditions producing maximum power output compatible with the direct plate voltage, saturation cathode current, and maximum grid and plate dissipation. Under these optimum operating conditions, which are determined by the construction of the tube, the grid-cathode alternating voltage e_g , and the plate-cathode alternating voltage e_p have definite values which are readily approximated for each type of tube.

In Fig. 7, there are shown for one tube of a symmetrical stage, the alternating voltages with respect to ground, U_c , U_g , and U_p , on the three electrodes. It is assumed that the amplifier has been neutralized and optimum operating conditions fulfilled.

The plate and filament circuits are tuned; all voltages U_c , U_g , U_p , e_g , and e_p are, consequently, in phase or in phase opposition. As the alternating component of plate current i_p flows through the cathode circuit, it is necessary to supply an exciting power $i_p U_c$ in addition to the power dissipated in the grids. The output power is $i_p U_p$, and the power amplification is equal to the ratio U_p/U_c , disregarding the grid power.

Neutralizing capacitances and the reactance between the grids must be adjusted to obtain neutralization, satisfactory excitation power and load resistance must be provided to operate under optimum conditions (e_g and e_p constant). Therefore U_c , U_g , and U_p must have certain definite values which depend on the value of the neutralizing capacitance. Indeed, from Fig. 7

$$U_g = U_c + e_g,$$

$$U_p = U_c + e_p.$$

The relation (4) determines the value of U_c as a function of C_N , e_g , and e_p :

$$U_c = \frac{-e_g + m_p e_p}{1 - m_c - m_p} \tag{6}$$

As a result, power amplification is

$$\frac{U_p}{U_c} = \frac{-e_g + (1 - m_c)e_p}{-e_g + m_p e_p} \tag{7}$$

It may be seen from (5), (6), and (7) that for constant power output from the tubes, the exciting power must be increased and the power amplification will decrease as the neutralizing capacitance is increased.

The value of neutralizing capacitance will influence operating conditions greatly. If the neutralizing capacitance is less than the plate-filament capacitance of the tube, the stage will operate with low excitation power and high power amplification. As an example, consider the following values but disregard the power dissipated in the grids:

$$C_{fg} = 30 \mu\mu\text{f},$$

$$C_{gp} = 20 \mu\mu\text{f},$$

$$C_{fp} = 4 \mu\mu\text{f},$$

$$e_g = -2000 \text{ volts},$$

$$e_p = 9000 \text{ volts},$$

$$C_N = 0.$$

The power amplification U_p/U_c is 16. The exciting power will be only 6.2 percent of the total output power.

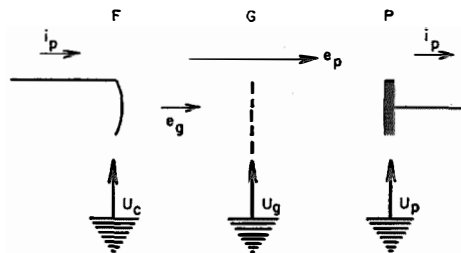

Fig. 7—Notation used in connection with one of the tubes.

If these tubes were used with neutralizing capacitances equal to the plate-cathode capacitances, the power amplification would be reduced to

$$\frac{-e_g + e_p}{-e_g} = 5.5.$$

If, finally, the neutralizing capacitances were greater than the plate-cathode capacitances, the power amplification would be still smaller, but the total output power possible would be increased.

To obtain an output power twice that of the exciting power $U_c i_p$, U_p/U_c should be equal to 2.

With the capacitances and voltages given in the above example, (7) gives the necessary value of neutralizing capacitance as

$$C_N - C_{fp} = 6.7 \mu\text{mf},$$

whence

$$C_N = 10.7 \mu\text{mf}.$$

Under these conditions, $U_c = e_p$. Power supplied by the tubes $e_p i_p$ will be equal to the exciting power $U_p i_p$. In this case, half of the available power at the output of the amplifier is obtained from the exciting stage. Notwithstanding this, the amplifier stage is at its optimum efficiency and the neutralization condition is fulfilled. This could not be realized with the neutralizing capacitance equal to the plate-cathode capacitance. For then the power amplification

$$\frac{-e_g + e_p}{-e_g}$$

could not be equal to 2 for the optimum operating conditions of the tube.

We therefore have the possibility of supplying the power to a single load from 2 stages using identical tubes. Each of the 4 tubes in Fig. 8 provides approximately the same power to the load. For high frequencies, this arrangement may be preferable to using 2 tubes in parallel on each side of a symmetrical stage.

3 Stability

As has been pointed out, if the neutralization condition is fulfilled, stability is not necessarily secured because in an inverted stage, the grid-cathode voltage depends on the current flowing in the plate circuit.

One reason for this is that the electronic or active plate current i_1 flows through the cathode circuit and

produces across the resistance R_1 of this circuit a voltage which decreases the exciting voltage. (See Fig. 9.) This corresponds to negative feedback.

The second reason is that the currents that flow through the grid-cathode and plate-grid capacitances produce across the grid reactance Z , a voltage which increases or decreases the excitation voltage depending on the value of Z . The resulting effect is either positive or negative feedback. If the positive feedback due to the reactance Z is greater than the negative feedback resulting from the cathode resistance, the amplifier stage can oscillate even though the coupling between the input and output circuits by capacitive currents is zero.

Confirmation of this is obtained by writing the relations necessary for a stage of the type shown in Fig. 5 to oscillate spontaneously at the operating frequency for which it has been neutralized and tuned. This condition occurs when the resistance presented by the circuit of Fig. 9 to the exciting electromotive force e is

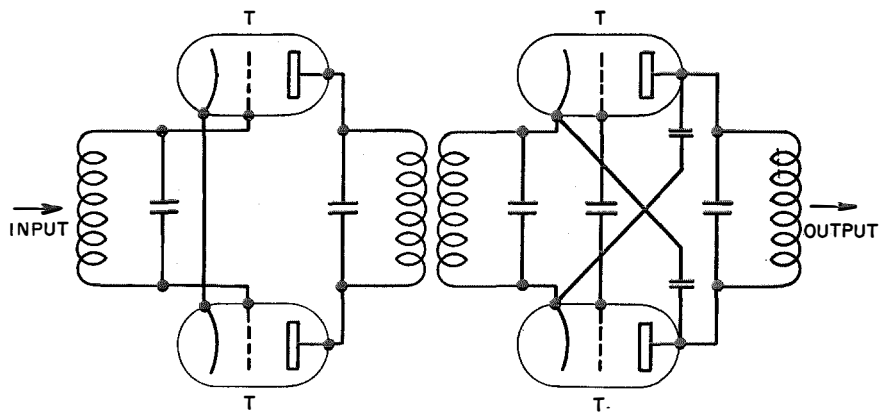

Fig. 8—Each of these 4 tubes contributes equally to the output power.

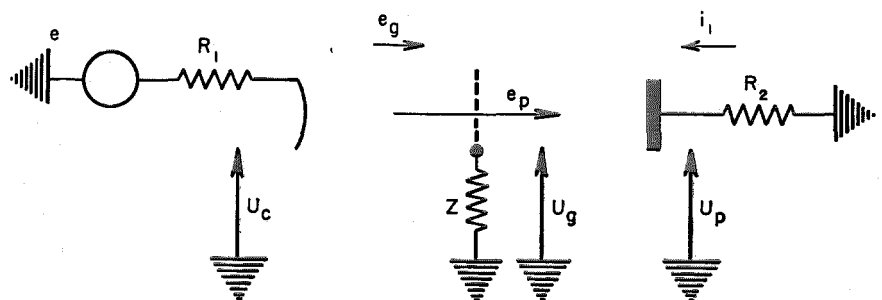

Fig. 9—Notation used in connection with one of the tubes.

negative. The following relation then exists:

$$R_1 + R_2 \frac{m_p + D + \frac{n}{SR_2}}{1 + D - m_c} < 0, \quad (8)$$

where

R_1 = resistance of the filament circuit,

R_2 = resistance of the plate circuit,

D = inverse of the amplification factor,

S = slope,

n = number depending on operating condition.

(Class A, B, or C. For class B, $n = 2$.)

This equation is only approximate as it is based on the assumption that the tube characteristics are linear. It is sufficiently accurate to describe the mechanism of operation.

From (8) it is seen that the amplifier stage can be unstable if m_p is negative, i.e., if the neutralizing capacitances are smaller than the internal capacitances, corresponding to an inductance between the grids. The oscillating condition is more readily obtained as the resistance of the cathode circuit R_1 becomes smaller, and as the neutralizing capacitance becomes smaller. One method of obtaining stability is to place in the cathode circuit a resistance R_1 sufficiently high that the conditions of (8) are not realized. The value of R_1 generally depends on the internal impedance of the exciter stage and this varies with the operating conditions.

From (5) it is evident that stability will be obtained if m_p is positive or zero which occurs when C_N is greater than or equal to C_{fp} and Z is capacitive. (In practice, the factor $1 - m_c$ is always positive.) Under these conditions, the amplifier will be stable for any plate resistance R_2 and cathode resistance R_1 , i.e., regardless of the load. Thus, among all the combinations of neutralizing capacitances and grid reactances which provide neutralization, it is possible to choose those values which also provide stability. The two problems can, therefore, be solved separately. The general stability problem is, of course, more complicated even when limited to the operating frequency.

4 Negative Feedback

Neutralization by cross-connected capacitances presents another advantage from the point of view of negative feedback. In such an amplifier, Fig. 9, calculation of the plate-to-

ground output voltage U_p as a function of the excitation voltage gives

$$U_p = \frac{SR_2}{n}(1 + D - m_c) \left[e - U_p \left(\frac{R_1}{R_2} + \frac{m_p + D}{1 + D - m_c} \right) \right].$$

This is the well-known equation of the input and output voltages of a negative-feedback amplifier; the direct amplification being

$$\mu = \frac{SR_2}{n}(1 + D - m_c),$$

and the reduction factor of the feedback circuit (Fig. 10) being

$$\beta = -\frac{R_1}{R_2} - \frac{m_p + D}{1 + D - m_c}.$$

As μ is real and positive, the feedback will be negative if β is negative.

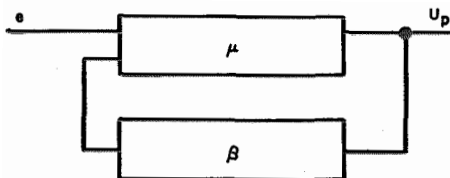

Fig. 10—General schematic of an amplifier with feedback.

The formula for β consists of two terms. The first R_1/R_2 indicates the importance of the negative feedback produced by the resistance of the cathode circuit. The other term measures the positive or negative feedback due to the currents which flow across the internal capacitances, the neutralizing capacitances, and the grid reactance. This term corresponds to a negative feedback when $m_p > 0$ and $(1 - m_c) > 0$, i.e., in the case where the neutralizing capacitances are greater than the internal capacitances, but not greater than $C_{fp} + C_{gp}$, a value which is not attained in practice. This negative feedback has a different origin than that resulting from the cathode resistance and is controlled by the value of the neutralizing capacitance.

An inverted amplifier with neutralizing capacitance greater than the plate-filament capacitance of the tube and with a capacitive reactance between the grids will then present all the advantages of an amplifier with negative feedback; in particular, the noise and distortion introduced by the stage when amplifying modulated signals will be reduced.



Fig. 11—Cathode-excited amplifier stage supplying a peak power of 60 kilowatts used in a 2-channel single-sideband transmitter mounted on trailers.

The ratio of noise and distortion reduction is equal to the feedback ratio.

$$\alpha = \frac{1}{1 - \mu\beta} = \frac{1}{1 + \frac{SR_2}{n}(m_p + D) + \frac{SR_1}{n}(1 + D - m_c)}$$

For example, with the following values:

$$\begin{aligned} S &= 5 \text{ ma/v,} \\ R_2 &= 4000 \text{ ohms,} \\ R_1 &= 0, \\ N &= 2, \\ D &= 0.03, \\ m_p &= 0.17, \end{aligned}$$

$\alpha = 1/3$, i.e., a rate of 9.5 decibels.

It should be noted that distortion due to grid current is much smaller for the inverted amplifier than for the grid-excited amplifier because the

grid current is small in comparison with the plate current and it is their sum which appears at the cathode circuit as a load on the excitation stage. This is independent of the negative feedback.

5 Results

A cathode-excited stage capable of supplying a peak power of 60 kilowatts (Fig. 11) was built as part of a 2-channel single-sideband transmitter which was mounted on trailers. The cathode-excited stage is coupled inductively to an intermediate driver stage. The filament-heating voltage is applied through a pair of coaxial choke coils. Frequency switching is performed manually by short-circuiting bars and by variable capacitors. Fig. 12 shows another inverted amplifier operating at 30 megacycles and giving a power output of 15 kilowatts with an amplification ratio of 4.

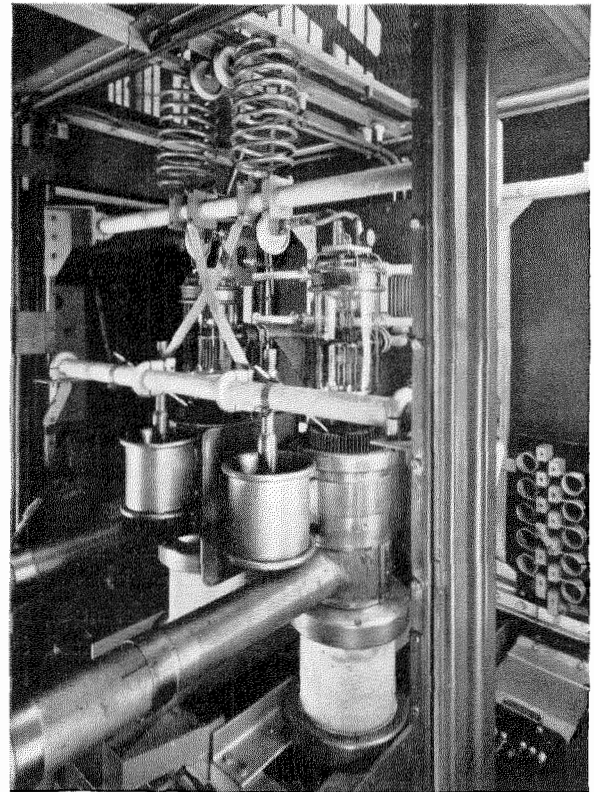

Fig. 12—Cathode-excited amplifier operating at 30 megacycles and giving a power of 15 kilowatts with an amplification ratio of 4. The two neutralizing capacitors are in the foreground.

Intermodulation measurements have been made on the amplifier shown in Fig. 11 by applying to the input of the exciting stage two voltages of equal amplitude and of different frequencies. After demodulation, the ratio of the amplitude of the intermodulation term to the common amplitude of the modulating voltages was measured. Power output is plotted against the ratio of the intermodulation term to the modulating voltage, expressed in decibels, in Fig. 13. This ratio varies between 25 and 40 decibels. For the maximum power output, the direct grid current is equal to about 0.1 of the direct plate current and the intermodulation ratio of 25 decibels is still acceptable.

With these distortion characteristics, telephone and simultaneous telegraph or facsimile operation may be employed. A normal operating condition was to use one channel for telephony

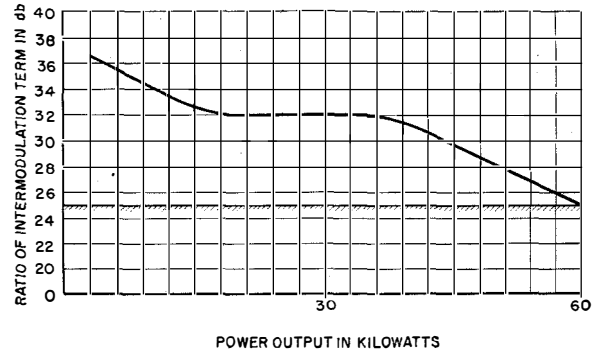

Fig. 13—Ratio of intermodulation term to modulating voltage as a function of power for a 60-kilowatt transmitter.

and the other for a 3-channel voice-frequency telegraph link. An interpretation of Fig. 13 in regard to cross talk will naturally depend on the average load at which each channel is operated.

Radar Vacuum-Tube Developments

By J. J. GLAUBER

Federal Telecommunication Laboratories, Inc., New York, New York

RADAR has brought about the development of transmitting equipment capable of generating extremely high powers at ultra-high frequencies. Such apparatus must withstand very high voltages. Special vacuum tubes are necessary and three triodes were developed for pulse-radar application which also have considerable interest as ultra-high-frequency generators, amplifiers, and frequency multipliers.

• • •

1 Radar Requirements

Before considering the construction, characteristics, and performance of radar tubes, it would not be amiss to consider briefly the fundamental requirements of a radar transmitter. A transmitter which radiates power P_t by a directive antenna in a beam of solid angle θ , see Fig. 1, will at some distance D produce a power density of $P_t/\theta D^2$ per unit area. If a target of area s is within the beam of radiation and reflects all the energy incident on it, the power reflected will be $sP_t/\theta D^2$. Assuming that s has no directive radiating properties, it may be considered a point source for spherical radiations. If the receiving antenna has an area b , it will intercept a portion of the reflected spherical wave in the ratio of its

area to that of the sphere of radius D or $b/4\pi D^2$. Thus the power intercepted by the receiving antenna is $(bsP_t)/(4\pi\theta D^2)$. Converting the solid angle of revolution θ to a plane angle ϕ by the relationship $\theta = \pi\phi^2/4$, the power received, $P_r = (bsP_t)/(\pi^2\phi^2 D^4)$. In an ordinary radio communication system, the power received by an antenna of area b at distance D from a transmitter radiating power P_t is $P_r' = (bP_t)/(4\pi D^2)$. The ratio of the power received in the communication case to that in the radar case is $P_r'/P_r = (\pi\phi^2 D^2)/(4s)$. Assuming ϕ the beam angle = 20 degrees ($\pi/9$ radians), $D = 500\,000$ feet (95 miles) and $s = 50$ square feet, the ratio $P_r'/P_r = 4 \times 10^8$. It is obvious that the power received in the radar case is only a minute fraction of that received by the ordinary radio communication method. Therefore, to have sufficient signal available at the radar receiver to overcome the inherent noise level requires that enormous powers be transmitted. Fortunately, the energy is transmitted in the form of pulses for short durations of time only with relatively long intervals of transmitter inactivity between pulses, resulting in a short duty cycle and small average power. However, the high peak powers in each pulse require tubes capable of high thermionic emission at high peak anode voltages.

It is very desirable to make the pulse durations as short as possible and the peak power per pulse as large as possible. As the radar antenna scans through space, it is desirable to have as many pulses transmitted per unit angle of scan as possible to detect a target. On the other hand, a sufficient interval between pulses must exist for the reflected wave from the target to return to the receiver. Approximately 1000 microseconds are required for an electromagnetic wave to travel 200 miles. If the transmitted pulse duration is 5 microseconds, the maximum number of pulses that may be transmitted per second is 995. However, some time interval must elapse between the end of the pulse transmission and the time the receiver becomes

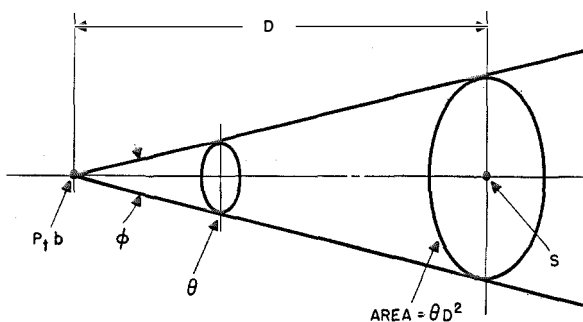

Fig. 1—Diagram of directive transmission to a target of area s to illustrate the need of high directivity and large powers in a radar system.

operative so the number of pulses possible per second would be a fraction of 995.

For reflection from a target, the wavelength of the impinging wave must be small compared to the dimensions of the target. Also, the shorter wavelengths can be confined to smaller beam angles, thus increasing the accuracy of the equipment.

From the above, it is apparent that large peak pulse powers and high frequencies are two prime requisites of pulse radar.

2 Tube Requirements

To obtain the large peak powers required, the vacuum tubes employed must be capable of delivering high peak emission currents at high voltages. The tubes are usually used as oscillators and modulation in the form of pulses is normally applied to the anode. During the interval between pulses, no power is applied to the anode. The pulse is thus the envelope of several radio-frequency cycles. The radio frequency is determined by the oscillator circuit constants.

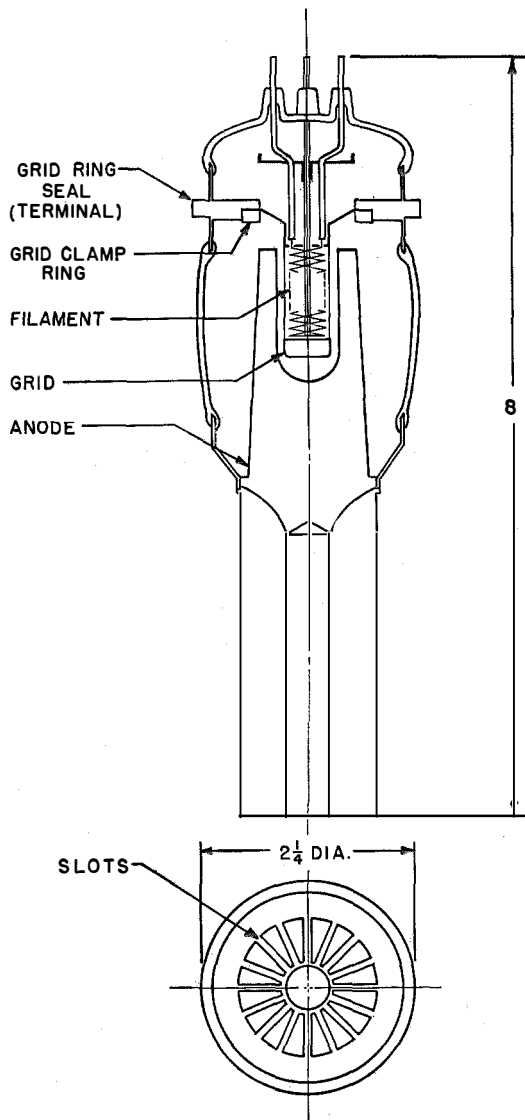

Figs. 2 and 3—L200, prototype of several tubes described in the paper. The output of two tubes in pulse transmission at 200 megacycles is 150 kilowatts.

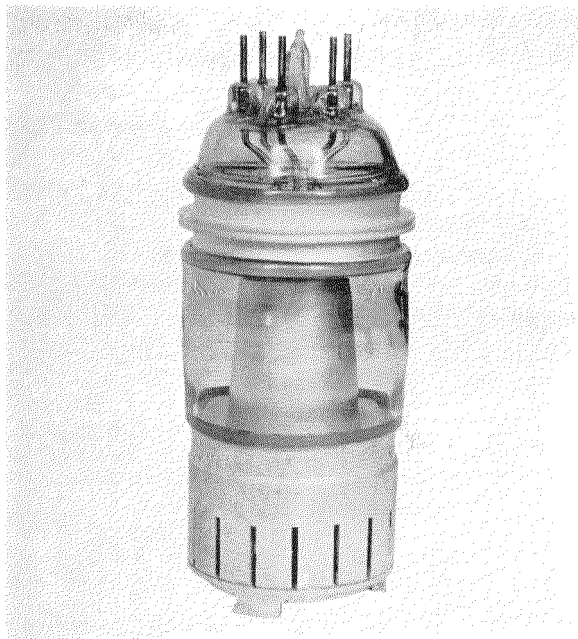

Fig. 4—L400. For pulse radar, two tubes will deliver 125 kilowatts at 400 megacycles.

Because of the high instantaneous voltages, internal spacing insulators between the tube electrodes should be omitted and the external glass paths made as long as possible. At the same time, rigidity of the electrode structure must be considered as the tubes are often used in military equipment in close proximity to gun fire.

Interchangeability of tubes in any equipment is highly desirable, and applies not only to electrical characteristics but to mounting means which must consider whether the tube be forced air cooled or water cooled.

In addition to uniformity, the tubes must maintain their original electrical characteristics for long periods of operation. It is essential that the available thermionic emission does not decay appreciably during operation.

Satisfactory life requirements have been met in pulse-radar tubes using thoriated-tungsten filaments or indirectly heated oxide-coated

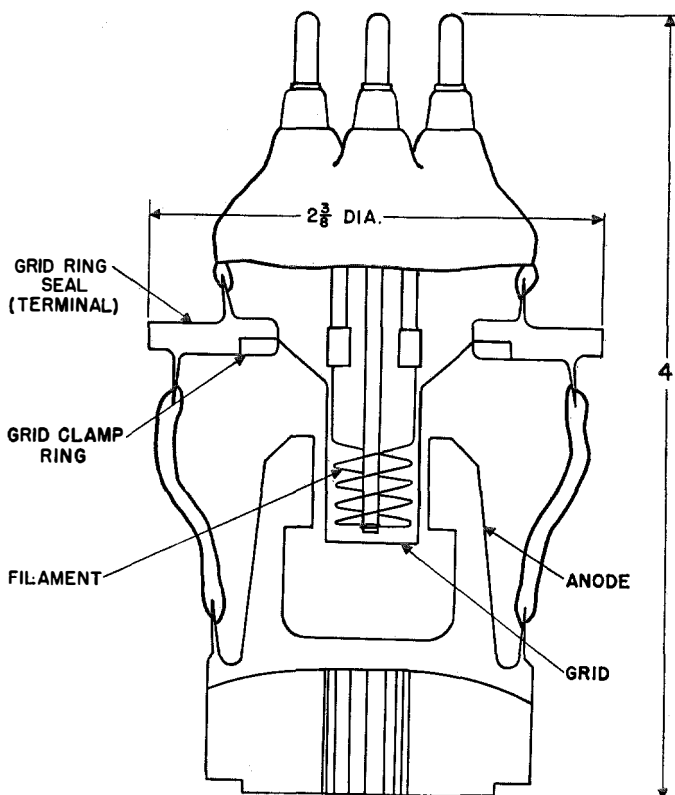
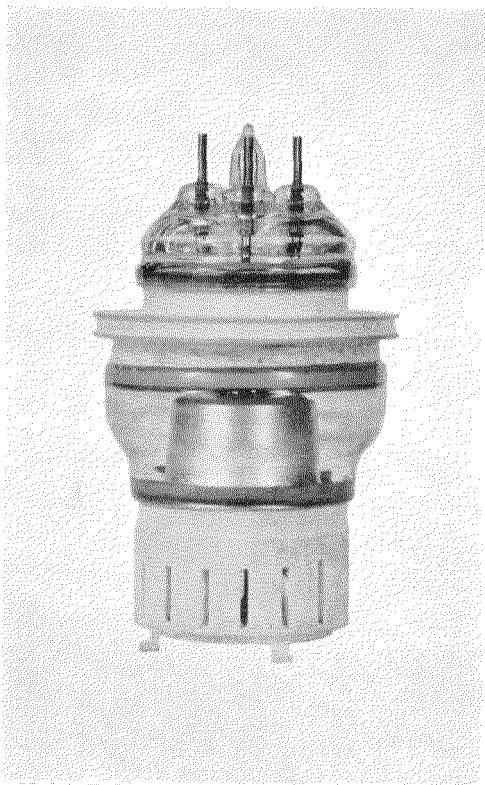

Figs. 5 and 6—L600E. A single tube in a pulse-radar circuit gives a peak power output of 25 kilowatts at 600 megacycles.

cathodes. The great advantage of the latter is that lower heater power and cathode inductance can be realized.

3 Preliminary Developments

During the latter part of 1941, a tube known as the L200 was developed. It was the predecessor and had the same general advantageous features of the tubes to be described later in this paper. A view of the L200 and a sectional drawing are shown in Figs. 2 and 3.

It is a cylindrical structure having a re-entrant copper anode, permitting a long glass path between anode and grid. A squirrel-cage-type grid is welded to a cone which is fastened to a copper clamp ring by four machine screws. This clamp ring is part of the ring seal to which the external circuits are connected. This structure assures a short low-inductance connection to the grid.

No solid insulators are used internally between electrodes and the grid shields the filament from the anode rather completely. The form and disposal of the filament, grid, and anode terminals provide ready connection to coaxial lines which may then form elongations of the electrodes.

The anode is forced air cooled by a blower connected to the anode coaxial line, which covers about 75 percent of the lower length of the anode. The air escapes through slots in the remaining substantially uncovered portion.

The operating characteristics are listed in Table I. Two tubes are capable of 150 kilowatts peak power output at 200 megacycles per second

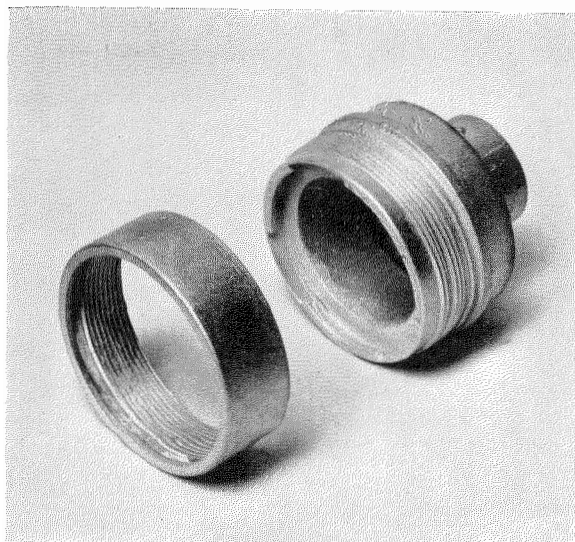

Fig. 7—Socket for L600E.

with pulses of 4 microseconds duration and 2500 pulses per second, i.e., 0.01 duty cycle.

With the trend to higher frequencies, another tube, the L400, was developed for pulse-radar application. The external anode length was made considerably shorter than in the L200 as is seen in Fig. 4. The electrodes were longer but the interelectrode clearances were greater and the amplification factor was increased to 20.

Two tubes are capable of 125 kilowatts peak power output at 400 megacycles and 0.01 duty cycle. A bayonet ring was soldered to the bottom of the anode to simplify changing tubes and to position tubes correctly in the coaxial-line circuit thus reducing adjustments.

TABLE I

L200, OPERATING CHARACTERISTICS

Cathode, Thoriated-Tungsten Filament	
Filament Volts	18.5
Filament Amperes	15.0
Total Emission Current (Amperes)	25
Amplification Factor	12
Mutual Conductance (ma/volt)	20
Capacitances ($\mu\mu\text{f}$)	
C_{gp}	9.5
C_{gf}	8.3
C_{pf}	0.7
Maximum Anode Volts, Pulse	35 000
Maximum Anode Dissipation (Watts)	700
Peak Power Output for 2 Tubes at 200 Mega- cycles (Kilowatts)	150
Air Circulation, Minimum (cfm)	40

4 Tubes for Pulse Operation

As radar development proceeded, it was evident that still higher frequencies and powers would permit increased accuracy and range.

4.1 TYPE L600E

A tube smaller than the L400 was developed for operation at 600 megacycles per second and is shown in Fig. 5. This tube, the L600E, is shown in section in Fig. 6 and the operating characteristics are shown in Table II.

It consists of a bifilar thoriated-tungsten filament, with its electrical center connected to a pin terminal, a squirrel-cage-type grid, and a re-entrant copper anode with a bayonet ring at its lower end to provide a simple means for securing and positioning the tube when used with the socket shown in Fig. 7. The anode and grid characteristic curves are shown in Figs. 8A and 8B, respectively.

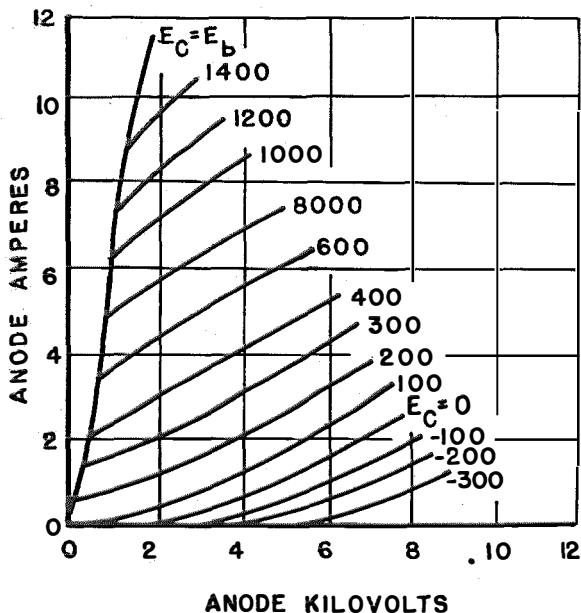

Fig. 8A—Anode characteristic curves of the L600E.

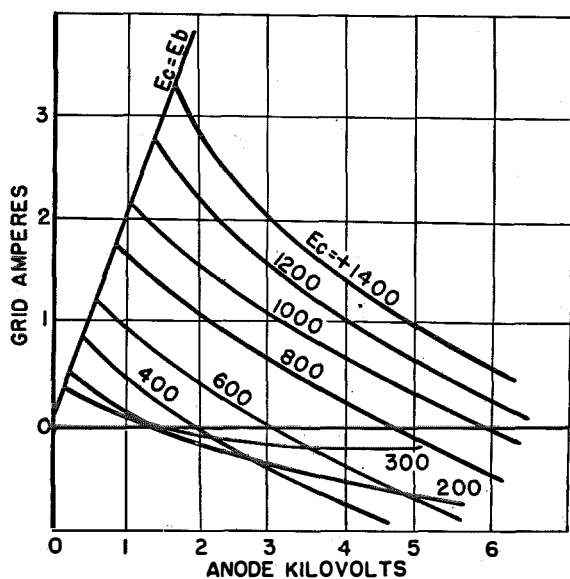

Fig. 8B—Grid characteristic curves of the L600E.



Fig. 9—8C22. At 400 megacycles, this tube will produce 500 kilowatts of peak power for pulse transmission.

A peak power output of 25 kilowatts could be produced by a single tube at 600 megacycles, with pulse anode modulation. In one application, with grid modulation, 7200 anode volts, and

TABLE II
L600E, 6C23, AND 8C22, OPERATING CHARACTERISTICS

	L600E	6C23	8C22
Cathode	Thoriated tungsten	Oxide coated	Thoriated tungsten
Filament Volts	6	7	4.25
Filament Amperes	14	26	320
Total Emission Current (Amperes)	15	300	200
Amplification Factor	20	21	9
Mutual Conductance (ma/volt)	8	100	26
Maximum Anode Volts, Pulse	25 000	25 000	25 000
Maximum Anode Dissipation (Kilowatts)	0.3	1	1
Peak Power Output, Kilowatts/Tube, Pulse	25	600	500
Frequency, Megacycles	600	600	400

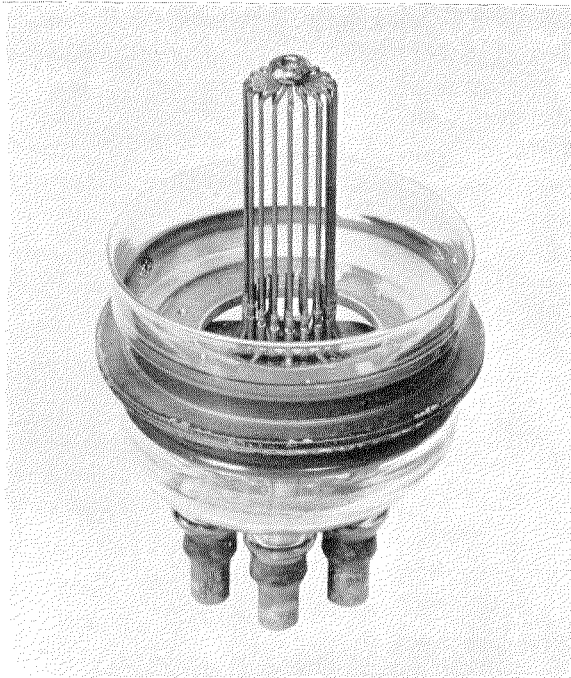

Fig. 10—Assembled center-tapped filament structure of the 8C22.

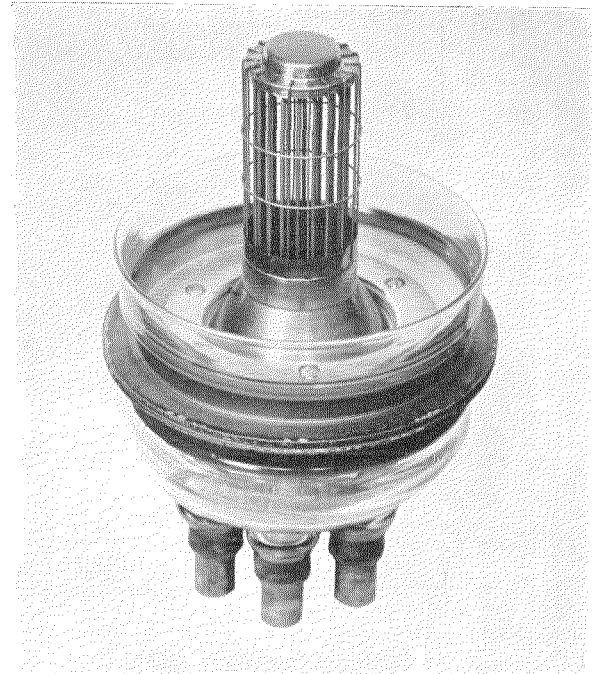

Fig. 11—The 8C22 has an 18-wire self-supporting squirrel-cage grid.

1.62 pulses per second of 200 microseconds duration each, a peak power of 7.3 kilowatts was developed at 600 megacycles with 33 percent efficiency. As a continuous-wave oscillator in a grounded-grid concentric-line circuit with 1000 anode volts, the efficiency at 600 megacycles was only 10 percent but at 300 megacycles, the efficiency was 40 percent.

4.2 TYPE 8C22

A thoriated-tungsten-emitter triode capable of delivering a very large peak power but at a lower frequency than the L600E was also developed. The tube, known as the 8C22, is much larger than the L600E but the physical arrangement of the electrodes is very similar, as may be seen from Fig. 9.

The filament is a self-supporting squirrel cage of low inductance, and having a center-tapped lead. It consists of 18 strands of accurately dimensioned thoriated tungsten electrically connected so there are 9 pairs in parallel. The assembled filament structure is shown in Fig. 10. The filament current is opposite in direction in any two adjacent strands. The magnetic fields

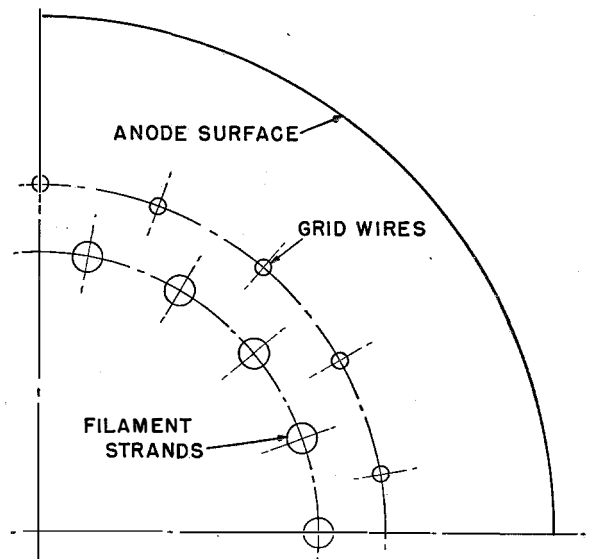

Fig. 12—Relative positions of grid strands and filament of the 8C22.

produce a mutual repelling force between strands. If the currents in two adjacent strands were in the same direction, a mutual attraction would exist and could ultimately result in the strands contacting in the vicinity of their mid-length.

If the cold filament of the 8C22 is connected to its exciting source, the excessive current, which flows while the filament is heating and approaching its operating resistance, will produce large magnetic forces which may in time have deleterious effects. It is, therefore, recommended that provision be made to limit the initial current to approximately 150 percent of the normal operating current.

The grid is also a self-supporting squirrel cage consisting of 18 wires and is shown assembled to its ring in Fig. 11. The positioning of the grid

strands with respect to the filament is shown in Fig. 12.

The anode is of the re-entrant type and is machined from a solid copper bar. Slots are milled in the lower portion for forced air cooling. A bayonet ring is soldered to the bottom of the anode.

The operating characteristics are listed in Table II. One tube is capable of 500 kilowatts peak power output at 45 percent efficiency at 400 megacycles with 27000 anode volts.

Anode characteristic curves are shown in Fig. 13 and a primary-grid-emission curve is shown in Fig. 14. The division of current between anode and grid with the same voltage applied to both is shown in Fig. 15. The average ratio of anode to grid current at the diode line is approximately 1.3:1 which is rather low.

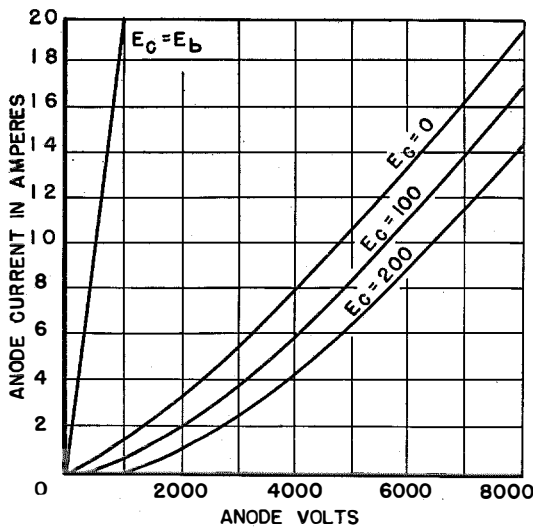

Fig. 13—Anode characteristic curves of the 8C22.

4.3 TYPE 6C23

While the 8C22 is capable of delivering large peak powers at 400 megacycles, it requires large filament power, approximately 1350 watts. A request by one of the services for a tube to deliver the power output of the 8C22 at 600 megacycles but with less filament power, resulted in the 6C23 which contains an indirectly heated oxide-coated cathode of large surface area. Fig. 16 shows the assembled tube and Fig. 17 shows the cathode-grid assembly.

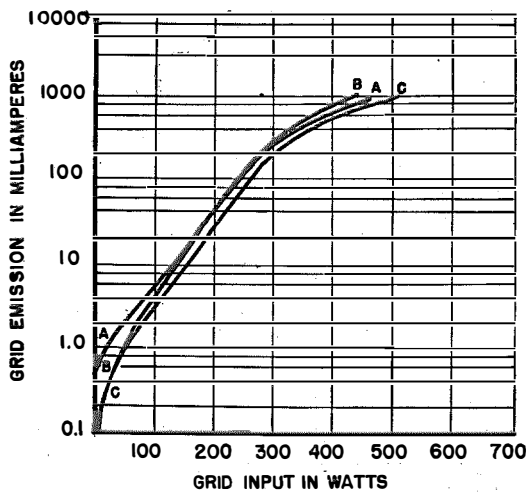

Fig. 14—Primary-grid-emission curve of the 8C22. The three curves are for filament powers of A = 1459 watts, B = 1326 watts, and C = 1193 watts.

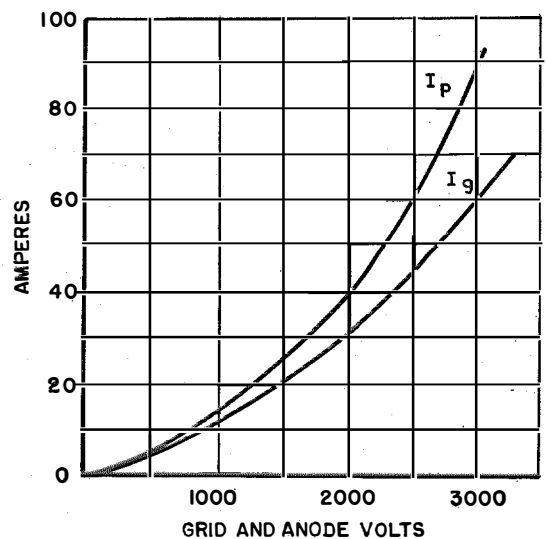

Fig. 15—Current division in the 8C22 with the same voltage on the grid and anode.

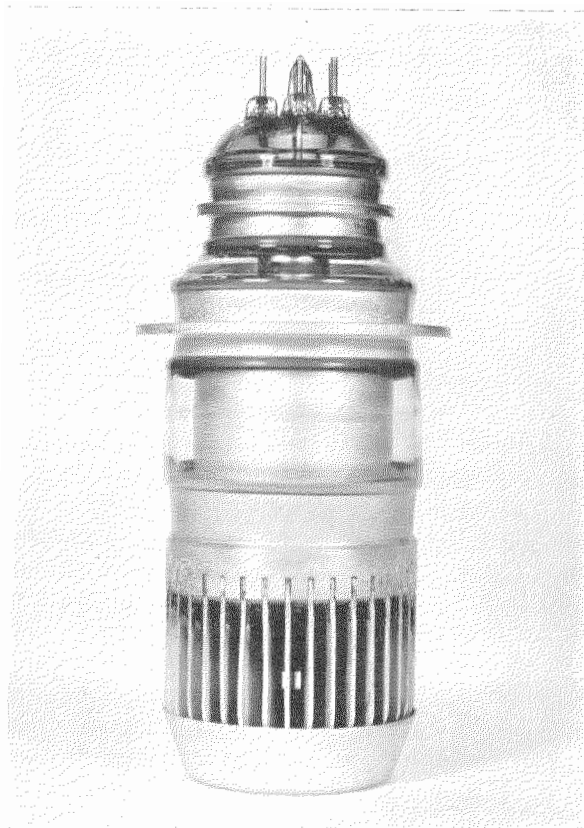

Fig. 16—6C23. A single tube will produce 600 kilowatts of peak power in pulses at 600 megacycles.

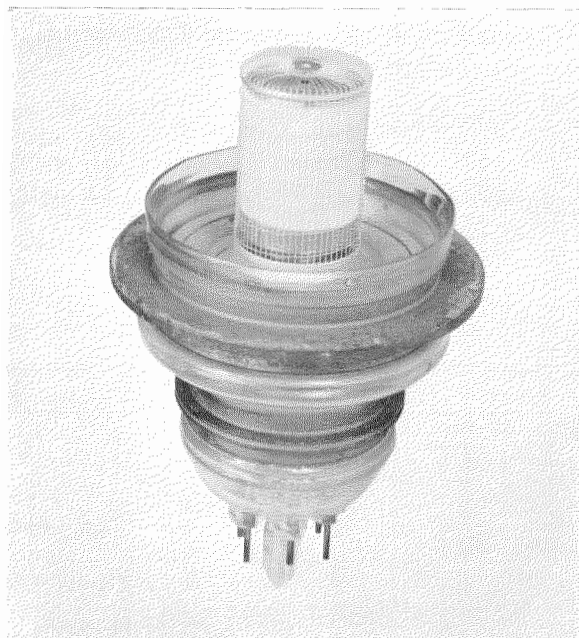

Fig. 17—Cathode and grid assembly of the 6C23.

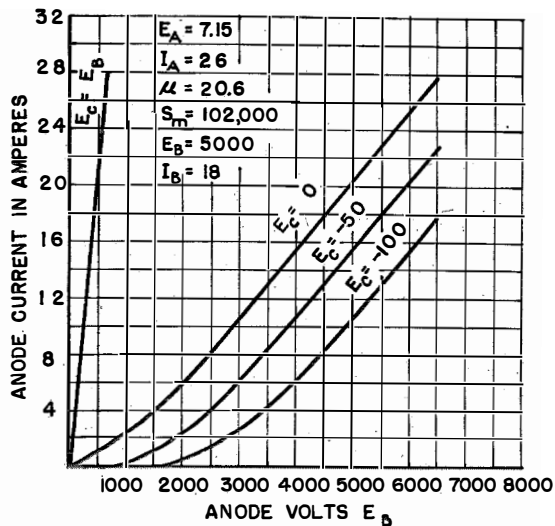

Fig. 18—Anode characteristic curves of the 6C23.

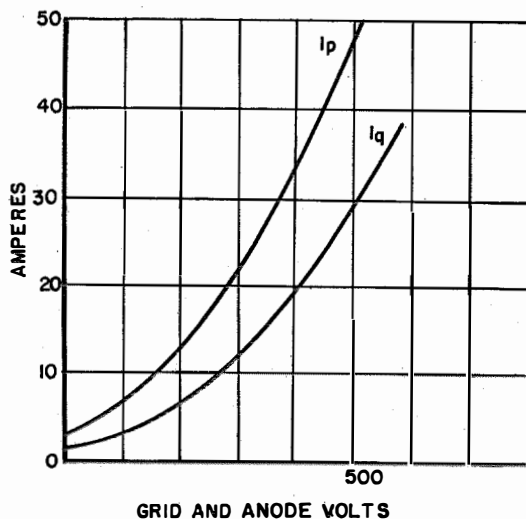

Fig. 19—Current division in the 6C23 with the same voltage on the grid and anode.

The outward appearance of the 6C23 is similar to that of the other tubes described with the exception that an additional ring seal has been added for the cathode. The heater leads are brought out through a molded glass flare. The heater is a quadrifilar tungsten wire helix.

Fig. 18 shows the anode characteristics and the operating data are given in Table II. The division of anode and grid current for the same voltage applied to both electrodes is shown in Fig. 19. The average ratio of anode to grid current at the diode line is approximately 1.8:1.

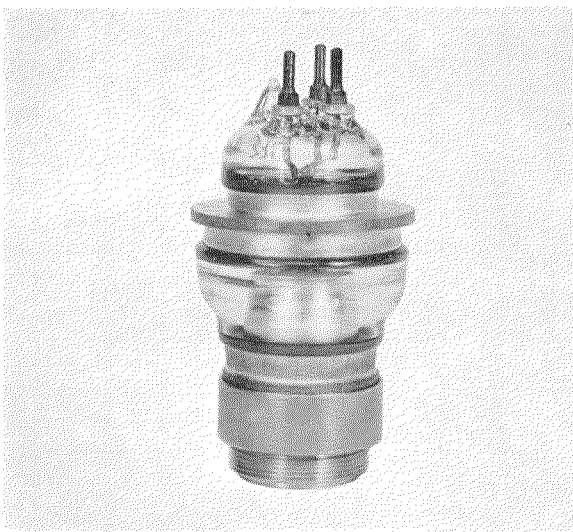

Fig. 20—6C22 is identical in appearance with the L600E except for the screw-type water jacket. As a continuous-wave oscillator, it will produce 250 watts at 600 megacycles and 500 watts as an amplifier.

On life test, a single-tube coaxial-line oscillator, at 600 megacycles, 15 000 anode volts, 3 micro-seconds pulse duration, 180 pulses per second, produced 560 kilowatts peak power output, equivalent to 300 watts average power, for 1200 hours, after which the tube ceased to oscillate.

5.1 Tubes for Continuous Waves

5.1 TYPE 6C22

While the L600E performed well as a pulsed tube, it was apparent that there was room for improvement in continuous-wave operation and a new tube, formerly known as the L600N but now registered as the 6C22, was developed. With the exception of the filament terminals and screw-type water jacket on the anode, it is identical in outward appearance to the L600E as may be seen in Fig. 20.

Internally, it is quite different. The thoriated-tungsten-filament helix is also bifilar but the wire diameter is 25 percent greater and the number of turns has been increased by approximately 35 percent. The outside diameter of the helix was increased and because the same grid is used as in the L600E, the grid-to-filament clearance was reduced by 59 percent. The anode diameter was reduced by approximately 20 percent.

In high-frequency tubes, transit-time effects must be given serious consideration. By decreasing interelectrode clearances, the deleterious effects due to the long time of electron travel compared with the period of the applied potentials is reduced. Transit-time effects are also decreased when high anode voltages are employed. Thus, a tube that may operate at a given high frequency with good efficiency under pulse conditions utilizing high voltages, may give very low efficiency in continuous-wave operation at the same frequency where lower anode voltages must be employed.

Because of this transit-time effect, all electrons emitted by the filament or cathode when the grid is positive do not reach the anode; many return to the cathode space-charge region. This causes a decrease in anode current and power output. To increase the anode current, the filament or cathode must supply a larger quantity of electrons to compensate for those electrons which could not reach the anode. The emission required at high frequencies may be several times as great as in low-frequency applications where transit-time effects are negligible.

These effects were taken into consideration with the result that the filament surface area of the 6C22 was increased as much as possible commensurate with rigidity and good nonsag characteristics.

The reduction in clearances and the increase in filament surface area resulted in a triode with a much higher perveance than that of the L600E. The characteristics are tabulated in Table III. The anode characteristics are shown in Fig. 21 and typical operating conditions for oscillator and amplifier are shown in Table IV.

TABLE III
6C22, L600NR, 6C23, AND 8C23,
OPERATING CHARACTERISTICS

	6C22	L600NR	6C23	8C23
Filament Volts	6.5	6.5	7	4.25
Filament Amperes	18.5	18.5	26	320
Amplification Factor	9	9	21	9
Mutual Conductance (ma/volt)	13	13	100	59
Maximum Anode Volts	3000	3000	1500	10000
Maximum Anode Dissipation (Kilowatts)	2	0.6	1	1 (Air Cooled) 5 (Water Cooled)
Maximum Grid Dissipation (Watts)	25	25	12	50
Capacitances C_{gp}	6	6	14	22
C_{gf}	7	7	24	37
C_{pf}	0.4	0.4	1.5	2
C_{ht}	—	—	9	—

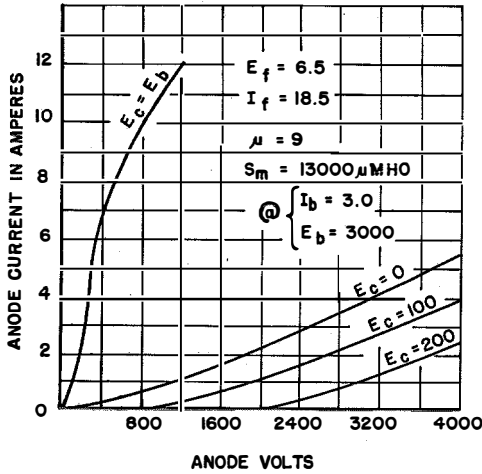

Fig. 21—Anode characteristic curves of the 6C22.

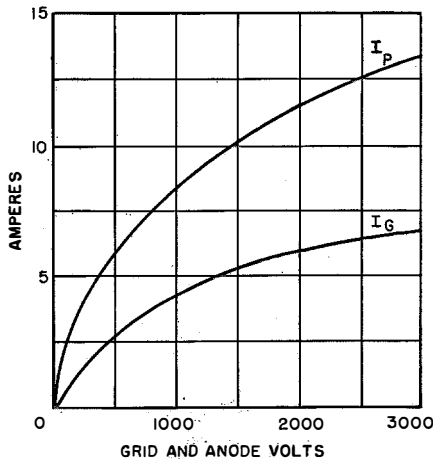

Fig. 22—Current division in the 6C22 with the same voltage on the grid and anode.

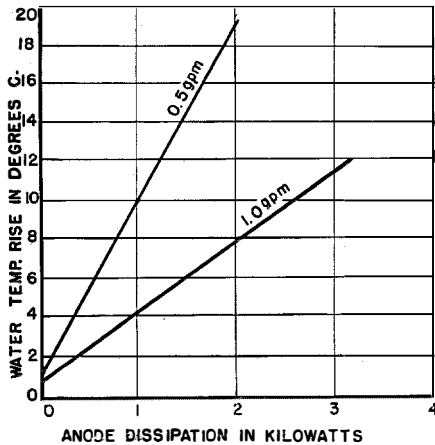

Fig. 23—Temperature rise of anode-cooling water plotted against anode dissipation for the 6C22. The curves are for 0.5 and 1.0 gallon per minute of cooling-water flow as indicated.

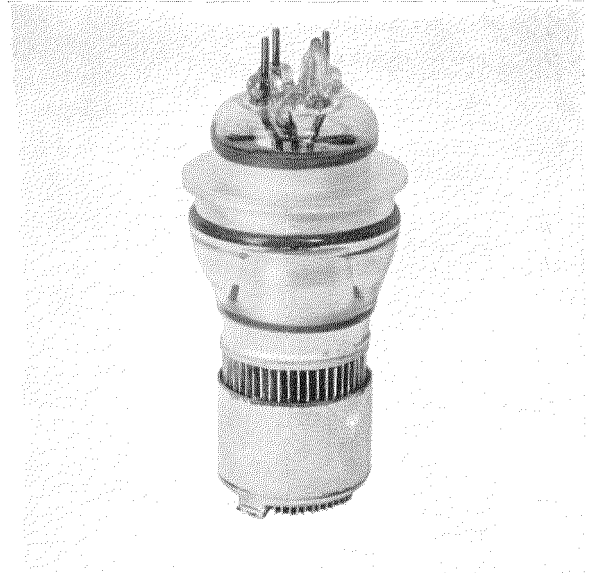

Fig. 24—L600NR is equivalent to the 6C22 internally but has radiating fins for forced air cooling.

TABLE IV
6C22, CONTINUOUS-WAVE OPERATING CONDITIONS

	Oscillator	Amplifier
Filament Volts	6.5	6.5
Filament Amperes	18.5	18.5
Direct Anode Volts	1200	1600
Direct Anode Amperes	0.6	0.7
Direct Grid Amperes	0.05	0.06
Power Output (Watts)	250	500
Anode Dissipation (Watts)	470	600
Efficiency (Percent)	35	45
Driving Power (Watts)		100
Frequency (Megacycles)	600	600

The tube was tested as an oscillator at frequencies higher than 600 megacycles. At 730 megacycles, a power output of 165 watts was obtained at 23 percent efficiency. At 1000 megacycles, a power output of 50 watts was obtained at 10 percent efficiency. As an amplifier with 2300 anode volts, a power output of 1000 watts was obtained at 600 megacycles with 51 percent efficiency and 200 watts driving power.

A curve of current division between anode and grid for the same voltage applied to both electrodes is shown in Fig. 22. The average ratio of anode to grid current at the diode line is approximately 2.5:1 which is rather good. A curve of anode dissipation versus rise in cooling-water temperature above the ambient is shown for flows of 0.5 and 1.0 gallon per minute in Fig. 23.

The 6C22 has undergone, without failure, vibration tests up to 11 g mounted in both horizontal and vertical positions, with 120 watts

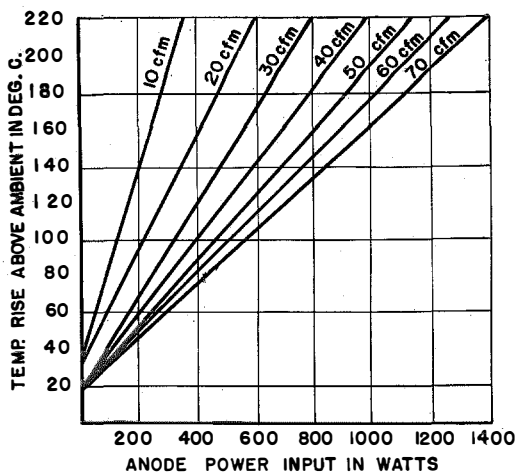

Fig. 25—Anode-seal-temperature rise of the L600NR is plotted against anode dissipation for several values of air flow in cubic feet per minute and a duct air temperature of 40 degrees centigrade. $\Delta t = t_p - (t_r + t_d - 40)$, where Δt is the temperature rise above ambient, t_p is the anode temperature, t_r is the ambient temperature, and t_d is the duct air temperature.

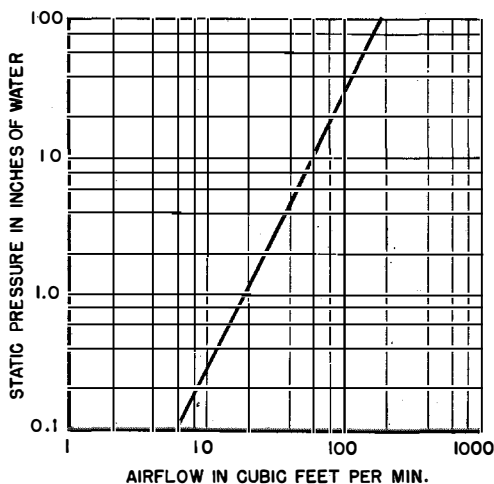

Fig. 26—Static pressure in inches of water plotted against air flow in cubic feet per minute for the L600NR.

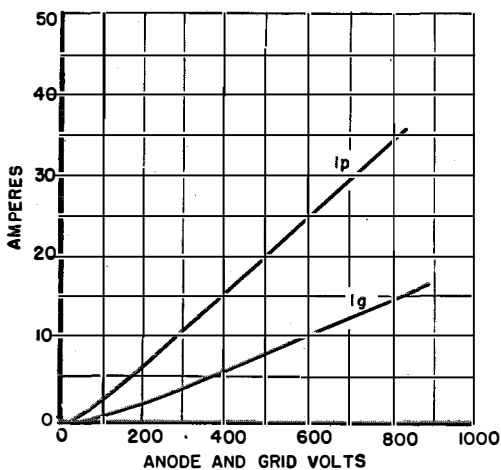

Fig. 27—Current division in the 8C23 with the same voltage on the grid and anode.

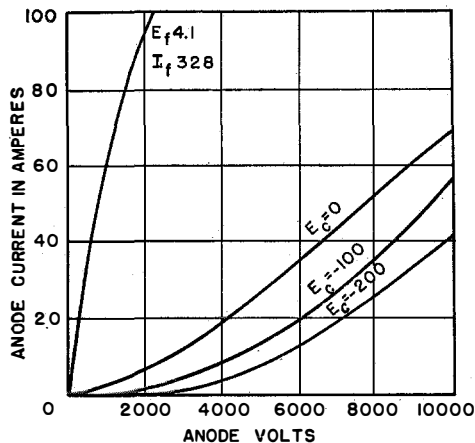

Fig. 28—Anode characteristic curves of the 8C23.

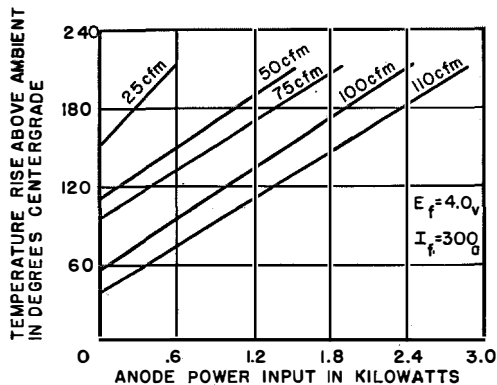

Fig. 29—Anode-seal-temperature rise of the 8C23 plotted against anode dissipation for various values of air flow in cubic feet per minute and duct air temperature of 40 degrees Centigrade.

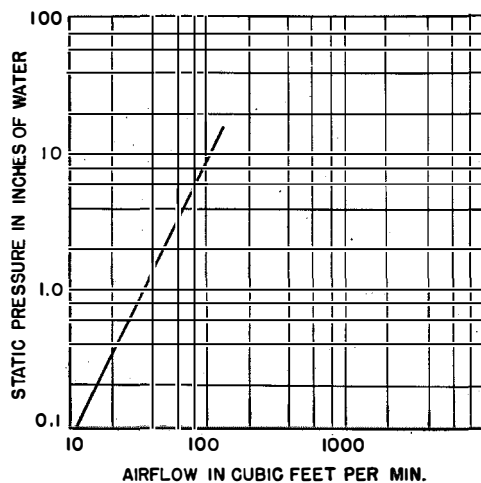

Fig. 30—Static pressure in inches of water plotted against air flow in cubic feet per minute for the 8C23.

filament and 20 watts grid power applied during the testing. On life tests, tubes operated for 500 hours as oscillators at 535 megacycles with 725 watts input at 35 percent efficiency showed only a very slight decrease in cathode emission.

An air-cooled version of the 6C22 known as the L600NR has been made and tested. Internally, it is identical to the 6C22 but externally it is quite different as may be seen from Fig. 24. Radiating fins have been attached to the anode and a bayonet ring provided for positioning. The characteristics are tabulated in Table III. The curve of anode dissipation versus anode-seal-temperature rise for various air flows is given in Fig. 25. The curve of air flow versus static pressure in inches of water is given in Fig. 26. From this figure, it is quite evident that for the low pressure required, a commercial-type blower is sufficient for cooling up to the maximum recommended anode dissipation of 600 watts. It is recommended for safe operation that the anode-seal temperature be limited to 150 degrees centigrade above ambient.

5.2 TYPE 8C23

The characteristics of the 8C22 have also been improved for continuous-wave applications. The improved tube, the 8C23, has the identical filament of the 8C22 but the grid diameter and wire size are smaller. In addition, a helix is wound over the 18 parallel strands. The anode diameter also is smaller than in the 8C22. The result is a tube with the same amplification factor but with a much higher perveance as shown by the tabulated characteristics in Table III and the current-division curve, Fig. 27. The improvement realized can be seen by comparison with Fig. 15. The average ratio of anode to grid current at the diode line is approximately 2.3:1. Some of the improvement in ratio is to be attributed to the slightly smaller clearance between anode and grid, but by far the greater part must be attributed to the change in grid structure.

It was found that the ratio was invariably greater if the grid laterals were perpendicular to the filament strands rather than parallel to them so that looking radially outward through the filament and grid, a mesh rather than parallel bars would be observed. The anode characteristics are shown in Fig. 28.

While the 8C23 is designed for forced air

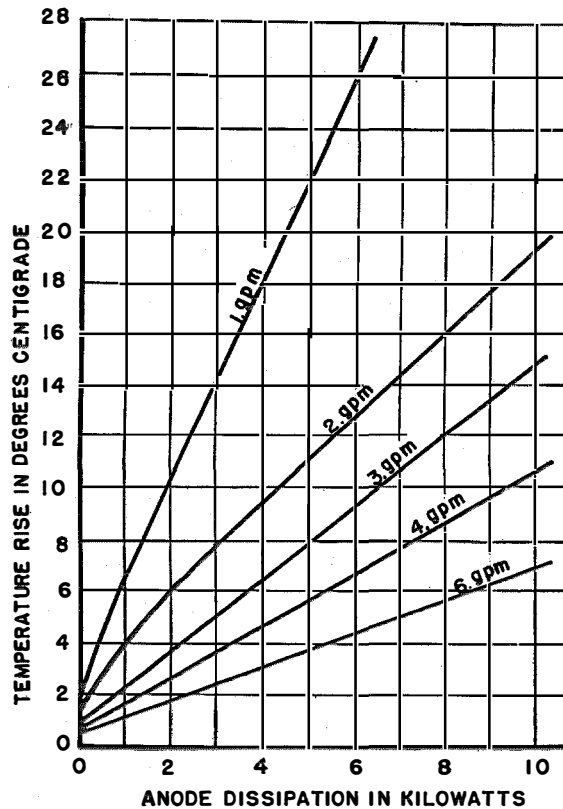

Fig. 31—Temperature rise of anode-cooling water plotted against anode dissipation for the 8C23 for various rates of water flow in gallons per minute.

cooling of the anode, a water jacket can be placed around the anode to increase its dissipation several times. The curves of anode dissipation versus anode-seal-temperature rise above the ambient and air flow in cubic feet per minute versus static pressure in inches of water are shown in Figs. 29 and 30, respectively. A large-size commercial-type blower or air through a reducing valve from a high-pressure line may be used.

The curve of anode dissipation versus temperature rise of anode-cooling water is shown in Fig. 31. The 8C23 with and without water jacket is shown in Fig. 32.

Tests as a continuous-wave oscillator have not been completed but indicate an efficiency of at least 35 percent at 400 megacycles which, with 1 kilowatt anode dissipation, would correspond to 500 watts output. With water cooling corresponding to 5 kilowatts anode dissipation, 2.7 kilowatts output are expected. At 600 megacycles, 1 kilowatt output is anticipated with 5 kilowatts anode dissipation.



Fig. 32—8C23 with (left) and without (right) water jacket.

5.3 TYPE 6C23

The 6C23 has not been tested for continuous-wave applications but tests have been made to determine the maximum anode direct voltage that is consistent with good life. It was evident that above 2000 direct volts on the anode, the oxide coating on the cathode was subject to back bombardment due to gas ions which had a ruinous effect on the coating. A typical example is shown in Fig. 33; the dark areas were caused by back bombardment. The cathode emission fell abruptly after this occurrence. It is, therefore, recommended that the maximum applied anode potential be limited to 1500 volts.

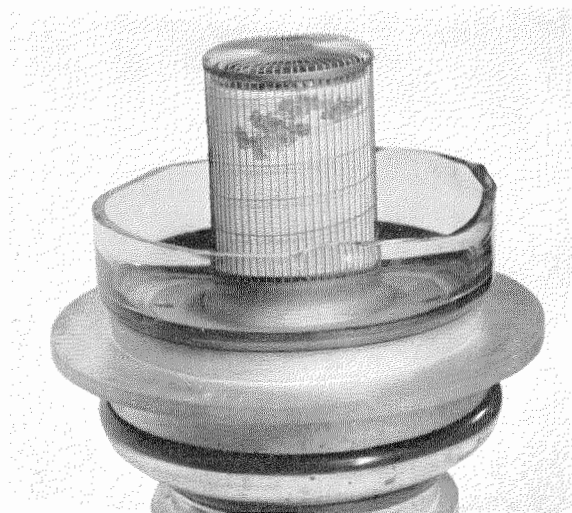

Fig. 33—Effects of cathode bombardment by gas ions as a result of excessive anode voltage may be seen above.

Curves of anode dissipation versus temperature rise of the anode seal above the ambient and

cooling as supplied by ordinary commercial-type blowers.

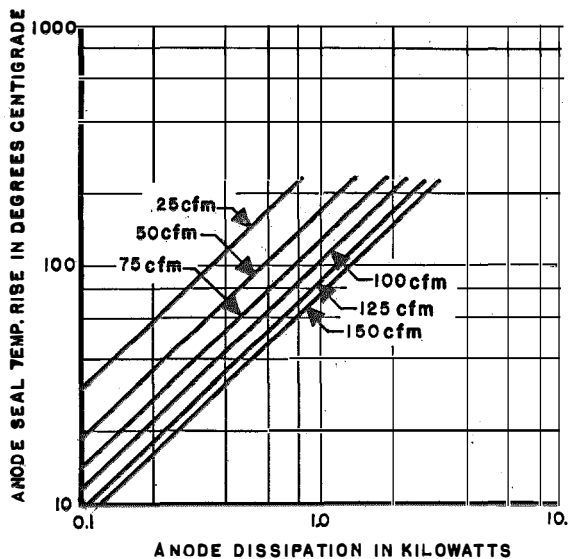

Fig. 34—Anode-seal-temperature rise of the 6C23 plotted against anode dissipation for various values of air flow in cubic feet per minute and a duct air temperature of 40 degrees Centigrade.

air flow in cubic feet per minute versus static pressure measured in inches of water are given in Figs 34 and 35, respectively. The finned anode has been specially designed for low-pressure air

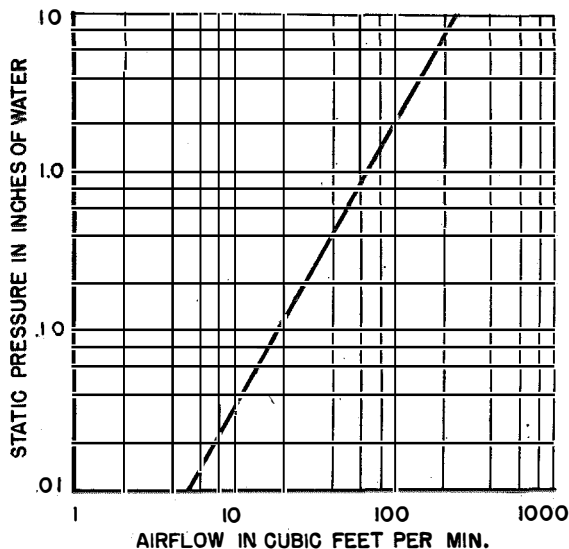

Fig. 35—Static pressure in inches of water plotted against air flow in cubic feet per minute for the 6C23.

6 Acknowledgment

The author expresses appreciation to the several members of the Federal Telecommunication Laboratories whose willing co-operation was of great assistance in gathering the data for this paper.

General Principles of Valve-Crate Design

By R. A. L. COLE, B.A.

Standard Telephones & Cables, Ltd., London, England

THE problem of transporting valves safely includes among other considerations the design of the valve crate. The simplest structure would use plain spring mounting to limit acceleration of the valve to a safe value.

Frictional damping can be added to check resonance oscillations of the valve in its crate but introduces a dangerous element of rigidity.

If the damping is made effective only after the valve has undergone a definite displacement, the probability of transmitting severe vibrations to structural features of the valve is reduced without substantially affecting the damping effect on resonance oscillations of the whole valve. This is called sprung damping.

The mathematics is greatly simplified by confining the treatment to the case of linear springing, although such springing is only approximately attainable in practice, and by ignoring all transient effects. This involves the assumption that all possible resonant frequencies within the valve are high compared with the natural frequency of the valve in its suspension.

Design considerations and formulae are given for the various methods of suspension, and a crate for a large valve weighing 120 pounds is described.

. . .

1 Calculations for Plain Springing

The simple case of a valve supported in its crate by undamped springs will be taken first. The following considerations apply equally well whether the system is isotropic or not. For a system which is anisotropic, the various constants will vary with direction. All the constants will apply to each direction considered separately with the constants appropriate to that particular direction.

Assume a valve of weight W pounds. By valve is understood the system consisting of a valve rigidly fixed in some sprung inner container with an allowance for the effective weight of the springs equal to $1/3$ of their actual weight. If we know that the maximum permissible acceleration of the valve, without damage, in the direction which for the moment is vertical, is N times the acceleration of gravity, the maximum permissible resultant force on the valve,

due to its supports, is NW pounds. N , so defined, is called the stiffness of the valve and must be greater than unity or the valve cannot be moved about at all.

If the valve is held in a crate by springs whose combined effect in the vertical direction is a central force of magnitude CX pounds, where X is the distance in inches of the centre of gravity of the valve from the force centre, then if the crate is dropped, the maximum permissible value of CX is NW pounds. C is called the strength of the suspension.

Before the crate is dropped, the valve will start from a point D inches below the force centre where $CD = W$.

If the valve in its crate must withstand dropping from a height of H inches, without damage, and X is the maximum permissible displacement from the force centre when so dropped, then

$$2W(H + X - D) = C(X + D)(X - D),$$

where

$$CD = W,$$

and

$$CX = NW.$$

Eliminating C/W and D , these equations give

$$X = \frac{2HN}{(N-1)^2},$$

whence

$$C = \frac{W(N-1)^2}{2H}.$$

As $W/C = D$, this gives a pair of equations in terms of H and N .

$$X = \frac{2HN}{(N-1)^2}, \quad D = \frac{2H}{(N-1)^2}.$$

Alternative pairs of equations are immediately deducible; in terms of D and N ,

$$X = DN, \quad H = \frac{D}{2}(N-1)^2;$$

in terms of D and H ,

$$X = D + \sqrt{2DH}, \quad N = 1 + \sqrt{\frac{2H}{D}};$$

in terms of X and D ,

$$H = \frac{(X-D)^2}{2D}, \quad N = \frac{X}{D};$$

in terms of X and N ,

$$D = \frac{X}{N}, \quad H = \frac{X}{2N}(N-1)^2;$$

and in terms of X and H ,

$$D = \frac{X}{K + \sqrt{K^2 - 1}}, \quad N = K + \sqrt{K^2 - 1},$$

where

$$K = 1 + \frac{H}{X}.$$

1.1 RULES

The following rules apply for crate design if plain springs only are to be used.

- a. Allow a clearance between crate and valve in all possible directions which is greater than $2HN/(N-1)^2$ inches.
- b. Suspend the valve by a spring system equivalent to a central force acting through the centre of gravity of the valve of magnitude equal to $W(N-1)^2/2H$ pounds per inch displacement of the centre of gravity from the force centre.
- c. Verify, for all possible displacements of the valve, that the springs cannot be stretched beyond their permissible extensions and that the law of the central force cannot break down through complete collapse of certain springs to their closed length.

1.2 DETERMINATION OF VALVE STIFFNESS

The stiffness N is best and most easily determined by means of carefully regulated dropping tests with a machine in which a valve can be suspended in any desired position by a simple spring suspension of calibrated strength. N can only be determined by destructive tests on an adequate scale for each direction considered.

Such tests will determine the minimum value of N in each direction for a batch of valves by subjecting each in turn to the same height of drop, repeating this for progressively greater heights until one valve is damaged. A series of suspensions of different strengths should be used to prevent the height of the machine from becoming unwieldy.

In general, it will be sufficient, for valves which are expected to withstand transit in any position, first to determine by experiment the

weakest position for the valve and then to determine N for that position. The crate suspension should be designed to give as uniform strength as possible in all directions, based on the minimum valve stiffness so found, with appropriate uniform clearance all round.

1.3 NOTE ON SPRINGS

Springs obey Hooke's Law, but they do not, in general, start from an unstrained state. For this reason the law of a spring must be expressed in the form $T = A(L - B)$, where T is the spring tension in pounds, L is the length of the spring in inches, and A and B are constants of the spring.

L may be measured either as total over-all length, or as effective total length inside the outer turns of the hooks, or as the length of the helix, but the definition which is adopted must be adhered to throughout as the constant B will have a different value in each case.

Springs can only be uniquely specified by giving limits for the length L , for two different values of the tension T , for both of which the spring must show some elongation. One value of T should be such as will produce a small elongation, the other such as will produce a considerable elongation. In addition, the length to which the spring must be capable of elongating without suffering permanent stretch must be specified. A spring can usually be made which will stretch elastically to twice its unstretched length.

2 Damping

Valves packed as above may safely survive a dropping test from rest but yet break up under particular conditions of vibration during transit.

This can occur either through resonance with the natural period of the whole valve in its spring supports or through resonance with the natural period of some structural feature of the valve itself.

The first type of failure, characterised by the building up of oscillations of the whole valve in its crate until it finally hits the crate and is damaged, can be avoided by introducing sufficient frictional damping in the suspension system.

The second type of failure cannot be avoided in this way but the danger is minimised by designing the suspension system to give as low a natural frequency as possible to the whole

system, so as to be as far away as possible from any natural frequencies which may be characteristic of the valve structure and hence reduce the danger of forced oscillations.

The frequency of vibration of the system is given by $\frac{1}{2\pi}\sqrt{\frac{12Cg}{W}}$, which is approximately

$3.13\sqrt{\frac{C}{W}}$, substituting for C , becomes $3.13(N-1)$

$\times\sqrt{\frac{1}{2H}}$. The smaller N and the greater H , the

lower this becomes. Hence, it may be wise, in designing a crate, to use in our calculations a fairly low N , even though we know that N for the valve is higher, also to use a value of H higher than the maximum drop which is actually anticipated. This will, of course, result in a larger crate, but it is the only way in which additional safety can be provided.

Unfortunately, the provision of frictional damping, to avoid the first type of failure, increases the danger of the second type of failure, as frictional junctions will freely transmit an oscillating force whose peak value is not high enough to cause slipping. For this reason the frictional damping should be kept to as low a value as will just prevent the build up of undesirably large oscillations of the valve in the crate. The value necessary for this purpose can only be determined by experiment. A mechanically driven vibration table for which the amplitude, direction, and frequency of vibration are continuously adjustable would greatly assist such design work.

2.1 CALCULATIONS INCLUDING THE EFFECT OF DAMPING

With the same assumption of a central force of magnitude CX pounds and an additional frictional force of FW pounds (F will in general be a small fraction), when the valve is moving downwards with respect to the crate after the latter has been stopped by hitting the ground, the upward force on a valve of weight W pounds will be $CX+FW$ pounds. The maximum permissible value of this is, as before, NW pounds.

Before the crate is dropped the valve may start from any point D inches below the force centre where $CD=W+EFW$, provided E is not greater than $+1$ nor less than -1 . This expresses the fact that the valve may be in equilibrium with the whole, or any fraction, of the frictional

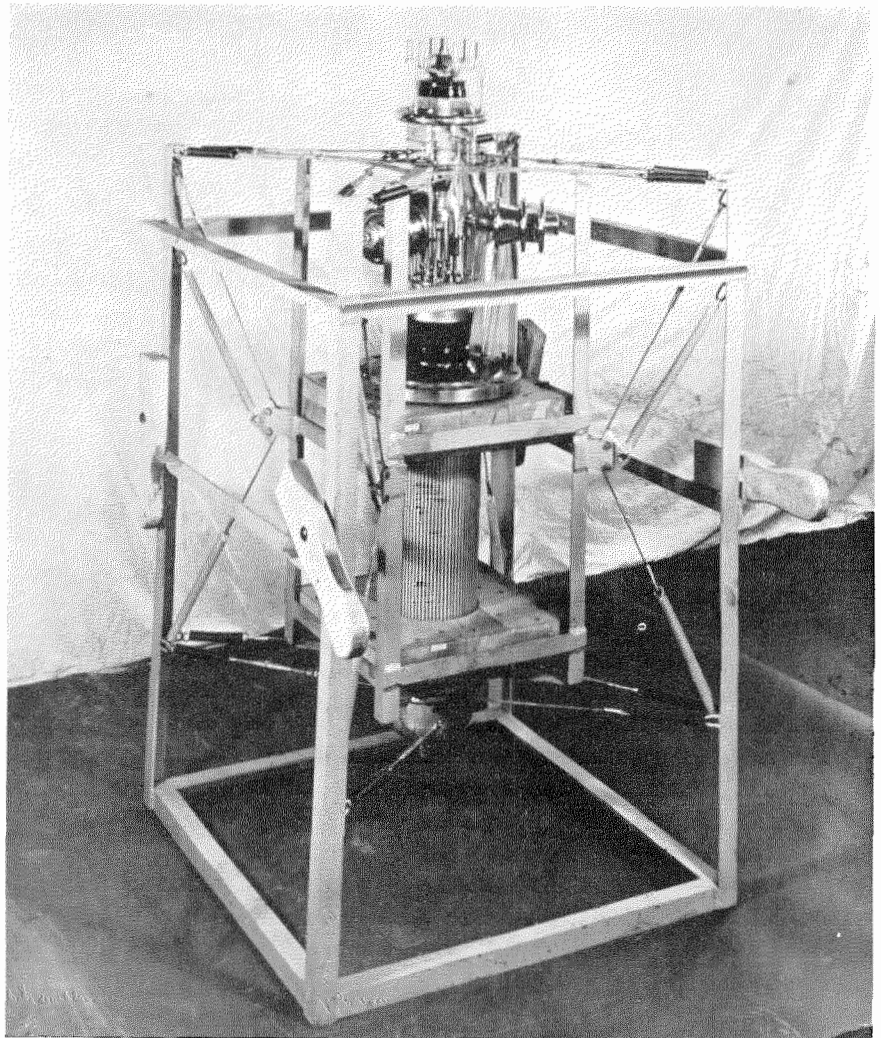

The side view of the crate shows clearly the quadrant-shaped blocks which provide vertical damping. The main supporting springs are anchored to these fixtures.

force either opposing or assisting the spring system.

Hence, to withstand dropping from H , if the maximum displacement, measured as before from the force centre, is X inches, we have the work equation

$$2W(H+X-D) = C(X+D)(X-D) + 2FW(X-D),$$

where

$$CD = W + EFW$$

and

$$CX + FW = NW.$$

This equation is slightly on the safe side as it neglects the small amount of work that may be absorbed by friction if the valve moves slightly the moment the crate is dropped. Eliminating

C/W , we have

$$2(H+X-D) = \frac{1}{X}(X^2 - D^2)(N-F) + 2F(X-D),$$

and

$$D = X \frac{1+EF}{N-F}$$

hence, eliminating D ,

$$2H + 2X - 2X \frac{1+EF}{N-F} = X(N-F) - X \frac{(1+EF)^2}{N-F} + 2FX - 2FX \frac{1+EF}{N-F},$$

hence,

$$2H(N-F) = X[2(1+EF) - 2(N-F) + (N-F)^2 - (1+EF)^2 + 2F(N-F) - 2F(1+EF)].$$

This reduces to

$$X = \frac{2H(N-F)}{(N-1)^2 - F^2(1+E)^2}$$

But E can vary from $+1$ to -1 , therefore, for any particular value of F , X is a maximum when E is $+1$, that is, when the valve starts from its lowest stable position in the crate with the maximum frictional forces opposing the spring system. In this case

$$X = \frac{2H(N-F)}{(N-1)^2 - 4F^2}$$

For all ordinary valves and systems of damping, N is at least equal to 3 and is probably much higher, also F should be kept to a value less than 0.3 for the reasons already given.

In all such cases, the value of X is a maximum when $F=0$, and reduces to $2HN/(N-1)^2$ as was found in the initial simplified calculation.

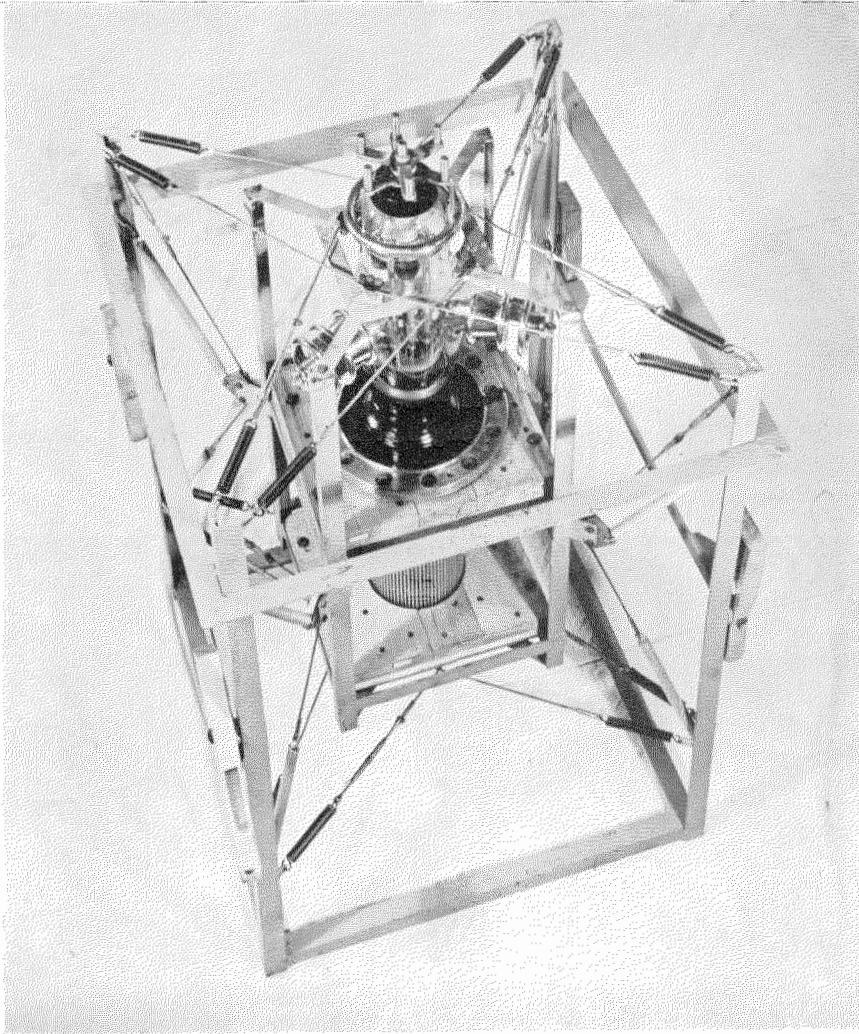

View from above of a 4067A valve suspended in a shipping crate. The blocks for horizontal damping have small steel guards to prevent the cables from jumping off. There are 4 similar blocks at the bottom of the structure.

This means that the same rule can be used for determining the crate size whether damping is used or not.

The rule for determining the law of the spring system is, of course, different with damping; it is

$$C = \frac{W(N-F)}{X}$$

or

$$C = \frac{W}{2H} [(N-1)^2 - 4F^2].$$

C is, therefore, slightly less for a damped system, as would be expected. The difference is negligible if N is greater than 10 as is usually the case. The above expression, of course, reduces to the rule for the undamped case if $F=0$.

2.2 LARGE VALVES

In the case of many large valves, it may be found that they can only be transported safely in one position. In this case the suspension should be designed for use in that position only, with the crate so shaped as to make handling and storage as easy as possible in that position but as difficult as possible in all other positions. Suitable marking will also be essential.

3 Sprung Damping

In special cases it may be found that the provision of enough damping, to reduce resonance vibrations of the whole valve in its spring supports to safe limits, will produce a dangerous degree of rigidity capable of transmitting frequencies which resonate with the natural period of some structural feature of the valve. In such cases the introduction of sprung damping may be considered.

Sprung damping is defined as damping which is not introduced until some member of the damping system has undergone sufficient elastic displacement to reach the point at which slipping will

occur and frictional losses be introduced. For example, a cable capable of slipping over a block fixed to the suspended system may be attached to the outer fixed system by means of a spring at each end, so that the cable can move lengthwise, elastically, until the difference between the tensions of the springs at the two ends is equal to the maximum frictional force between the block and the cable. After this point has been reached the cable will slip on the block and introduce damping.

3.1 CALCULATIONS FOR SPRUNG DAMPING

D = initial displacement of valve below force centre in inches.

C = strength of valve suspension in pounds per inch.

W = weight of valve in pounds.

H = height of drop in inches for crate.

N = stiffness of valve, a pure number.

FW = maximum friction in pounds that damping applies when slipping.

J = initial upward displacement of the damping system from its equilibrium position, in inches.

Y = maximum downward displacement of the damping system from its equilibrium position at the point of slipping, in inches.

E = ratio of J to Y , which must lie between +1 and -1.

G = strength of damping suspension in pounds per inch.

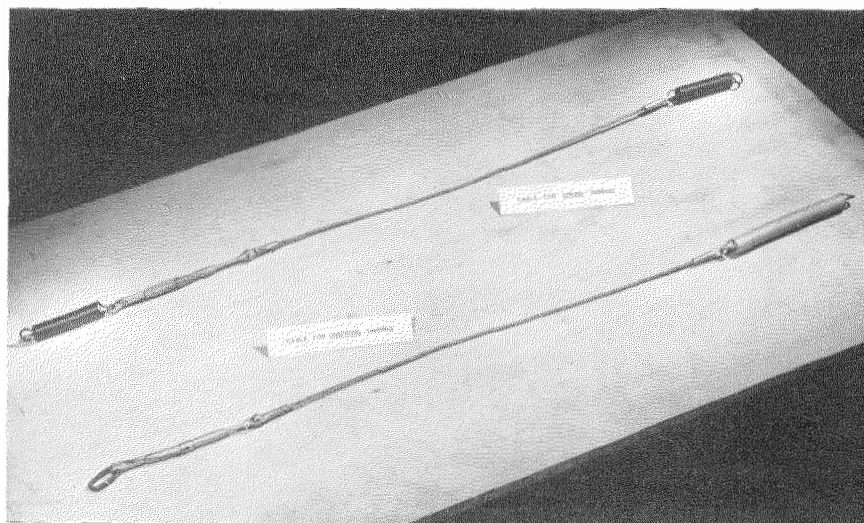

Cables used in the damping systems. The turnbuckles are used for adjusting tension and are wired to prevent unscrewing through vibration.

X = maximum downward displacement of valve below force centre after dropping.

The condition for initial equilibrium is

$$CD = W + GJ. \quad (1)$$

The slipping condition is

$$FW = GY. \quad (2)$$

The stiffness condition is

$$NW = CX + FW. \quad (3)$$

The initial frictional equilibrium condition is

$$J = EY. \quad (4)$$

The work done by gravity on dropping the crate is

$$W(H + X - D).$$

The work done on the suspension system of the valve is

$$1/2C(X + D)(X - D).$$

The work done on the damping-system suspension is

$$1/2G(Y + J)(Y - J).$$

The work done against friction after slipping starts is

$$FW(X - D - Y - J),$$

neglecting, as before, any small amount of work absorbed by friction if the valve moves slightly the moment the crate is dropped.

Hence we have the work equation

$$2W(H + X - D) = C(X^2 - D^2) + G(Y^2 - J^2) + 2FW(X - D - Y - J). \quad (5)$$

Eliminating J between (1) and (4) we have

$$CD = W + EGY. \quad (6)$$

Eliminating J between (4) and (5) we have

$$2W(H + X - D) = C(X^2 - D^2) + GY^2(1 - E^2) + 2FW(X - D - Y - EY). \quad (7)$$

Eliminating G between (2) and (6) we have

$$CD = W + EFW. \quad (8)$$

Eliminating G between (2) and (7) we have

$$2W(H + X - D) = C(X^2 - D^2) + FWY(1 - E^2) + 2FW(X - D - Y - EY). \quad (9)$$

Eliminating C/W between (3) and (8) we have

$$D(N - F) = X(1 + EF). \quad (10)$$

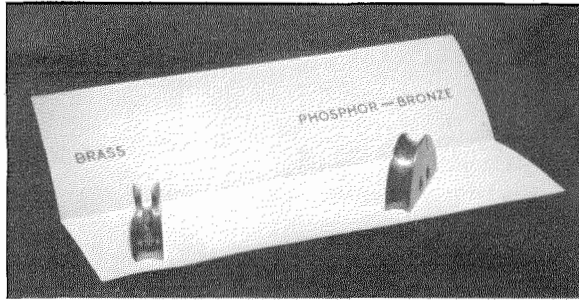

Relative wear on a brass and on a phosphor-bronze damping block produced by life testing. The phosphor-bronze block has worn only 0.020 inch.

Eliminating C/W between (3) and (9) we have

$$2(H + X - D) = (N - F)(X^2 - D^2)/X + FY(1 - E^2) + 2F(X - D - Y - EY). \quad (11)$$

If we carry out the elimination of D between (10) and (11) it can be shown that

$$X = \frac{(N - F)[2H + FY(1 + E)^2]}{(N - 1)^2 - F^2(1 + E)^2}. \quad (12)$$

X is a maximum when E is $+1$, that is, if the valve starts with $J = Y$, or, as before, with the maximum frictional force opposing the suspension. In this case

$$X = \frac{2(N - F)(H + 2FY)}{(N - 1)^2 - 4F^2}. \quad (13)$$

From (3) and (13)

$$C = \frac{W(N - 1)^2 - 4F^2}{2(H + 2FY)}. \quad (14)$$

3.2 EFFECT OF SPRUNG DAMPING ON NATURAL FREQUENCY

Within the small degree of movement tolerated by the damping system before the slipping point is reached the strength of the damping suspension will be added to the strength of the true suspension so that the natural frequency will become approximately

$$3.13\sqrt{\frac{C + G}{W}}. \quad (15)$$

The higher G , the higher this natural frequency. To keep the natural frequency as low as possible, the design should aim at keeping G low while, at the same time, keeping the value FW of the frictional force when slipping occurs, high enough to give satisfactory damping.

3.3 GENERAL REMARKS

Sprung damping is much more beneficial than direct damping as it enables one to render harmless both types of dangerous resonance vibration.

It is almost as easy to apply when the damping is produced by a slipping cable, involving only the division of the cable tension spring into two equal parts and the placing of one part at each end of the cable instead of the whole at one end.

The expressions for X and C for the case of direct damping are immediately deducible from the more-general expressions (13) and (14) by putting $Y=0$. This expresses the fact that work is done against friction directly the valve moves in the crate. The original expressions for the simple undamped case are deducible by further putting $F=0$ as already mentioned.

The calculations have been given for each case separately, instead of deducing the results from the general case, as the argument is more easily followed in this way.

From the expression (15) for the natural frequency of the suspended valve, in the case of sprung damping when movement is not sufficient to produce slipping, we can readily see the danger to the internal structure introduced by unsprung damping, for in this case $Y=0$, whence, from (2) as FW is finite G must be infinite. In a practical case Y can never be quite 0, owing to the elasticity of the framework, but may be extremely small, so that G is extremely large. Therefore, the natural frequency will be very high with consequent danger to the internal structure.

4 Appendices

4.1 APPENDIX A

Table I gives N (the number of times gravity that a valve must be able to stand) in a given direction, if it is to be packed in such a way

TABLE I
Values of N

H (Drop in Inches)	X (Clearance in Inches)						
	1	2	3	4	6	8	12
12	26	14	10	8	6	5	4
24	50	26	18	14	10	8	6
36	74	38	26	20	14	11	8
48	98	50	34	26	18	14	10
60	122	62	42	32	22	17	12

that the space available for free movement in that direction, before it is stopped by the crate, is X inches and if the packed valve must withstand a dropping test from a height of H inches.

4.2 APPENDIX B

The photographs illustrate the application of the theory to the packing of the 4067A valve, which weighs about 120 pounds.

Damping is provided by flexible cords sliding on snubber blocks. Both cords and blocks are well lubricated with bearing grease.

The horizontal damping cords have springs at each end to provide sprung damping. It will be seen that they are so arranged as also to provide a central restoring force assisting the main springing.

The vertical damping cords have springs at their lower ends only, as in the vertical direction sprung damping was found to be unnecessary. These cords also provide a central restoring force.

Each damping cord consists of 6 strands laid up right-handed on a fibrous core. The individual strands are composed of 19 galvanised steel wires, (1+6+12), laid up left-handed.

A preliminary life test carried out by utilising the frame of a power-driven hacksaw gave the results illustrated. The blocks are phosphor bronze and brass, respectively. Each was run for 4 hours against a piece of damping cord tensioned and lubricated to simulate the crate condition.

The blocks were originally identical in shape. They are 2 inches in diameter. The wear on the phosphor-bronze block is scarcely visible although the brass block is worn, by the cord, right down to the fixing holes. The cords were not visibly worn. This experiment was decisive in favour of phosphor bronze for the snubber blocks.

The crate behaves very well in practice. Valves have been safely shipped, by lorry, in these crates from Ilminster to Penrith, a distance of 300 miles, over road surfaces of varying quality. The valves ride gracefully with long-period oscillations which quickly damp out.

One valve, the glasswork of which was accidentally broken right round the bulb while it was at Penrith, was brought back to Ilminster by road in one of these crates, without suffering any further damage. This was a very severe test.

Spiral Delay Lines

By K. H. ZIMMERMANN

Federal Telephone and Radio Corporation, Newark, New Jersey

THE time delay of a solid-dielectric transmission line is often used as a timing or calibrating device in radio applications, especially radar and television. However, when a time delay greater than that possible with the usual line is desired, it is necessary to employ especially constructed lines referred to as "delay lines."

• • •

Except for the inner conductor, the delay line, shown in Fig. 1, is exactly similar in appearance and construction to the solid-dielectric coaxial transmission line used at radio frequencies. The inner conductor is a helix of enamelled wire closely wound over an insulating core. This construction increases the inductance while the capacitance remains substantially the same.

Time delay, which is the reciprocal of velocity of propagation, can be computed from the inductance L and the capacitance C of the transmission line. The inductance of a continuously wound single-layer coil is given by the relation:

$$L = 3.06 \times 10^{-2} \pi^2 n^2 a^2 \text{ microhenries per foot, (1)}$$

where n = number of turns per inch

a = diameter of coil between wire centers, in inches.

The capacitance of a coaxial line is given by the relation:

$$C = \frac{7.36K \times 10^{-6}}{\text{Log}_{10} D/d} \text{ microfarads per foot, (2)}$$

where K = dielectric constant of insulating material

D = diameter over the dielectric

d = diameter over the inner conductor.

The time delay of a delay line is considerably higher than that of the usual coaxial line because of the increased inductance of its inner conductor.

$$T = \sqrt{LC} = \frac{4.76 \times 10^{-4} \pi n a \sqrt{K}}{\sqrt{\text{Log}_{10} D/d}} \text{ microseconds per foot. (3)}$$

From this relation, it is apparent that the time delay of this line depends not only on the dielectric constant of the insulating material but also on the construction of the inner conductor and on the physical dimensions of the line.

Since the inductance of the delay line has been increased, it follows that the characteristic impedance has also been increased.

$$Z_0 = \sqrt{\frac{L}{C}} = \frac{64.5 \pi n a}{\sqrt{K}} \sqrt{\text{Log}_{10} D/d} \text{ ohms. (4)}$$

A high-impedance transmission line is often required in video-frequency transmission where it is desirable to drive a terminated line from a high-impedance source. In general, coaxial lines are designed for 30 to 150 ohms impedance. However, with the spiral-delay-line construction, it is possible to obtain impedances of 1000 ohms and higher without increasing the dimensions beyond practical limits.

The first manufactured delay line, K-71, was produced in response to a demand for flexible lines of sturdy construction. Originally, these lines were wrapped by hand over plastic cores. The characteristics of K-71 are shown in Table I.

Delay lines have many applications in the video-frequency range of radar and television. In pulse-forming networks, a delay line is charged with direct current and then discharged

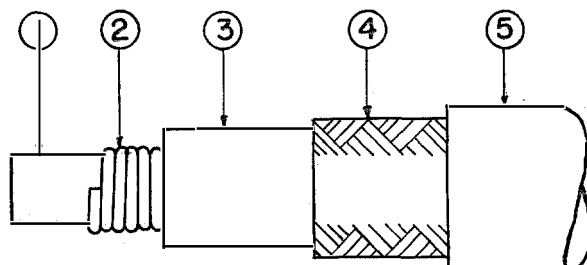

Fig. 1—Construction of spiral delay line.

- 1—Insulating Core
- 2—Spiral-Wound Enamelled Wire
- 3—Dielectric
- 4—Braid
- 5—Jacket

TABLE I
CHARACTERISTICS OF K-71

Characteristic Impedence, Ohms	950
Capacitance, Micromicrofarads per Foot	44
Time Delay, Microseconds per Foot	0.042
Over-All Diameter, Inches	0.415

to obtain a unidirectional pulse with a width equal to twice the one-way delay of the line.

Radar systems use delay lines to obtain varying voltages with varying time relationships in synchronizers or timers. Delay lines are used with cathode-ray oscilloscopes and synchronizers to view the leading edges of pulses. The delay line is inserted after the amplifier section from which the synchronizing voltage is obtained and delays the pulse until the sweep has been triggered.

Reference Data for Radio Engineers, Second Edition

A Second Edition of Reference Data for Radio Engineers has been published by the Federal Telephone and Radio Corporation in response to the interest shown in the First Edition, of which over 50000 copies were sold. Like the First Edition, it is presented as an aid to radio research, development, production, and operation. Widespread acceptance of the four printings of the First Edition, as well as declassification of many war developments and numerous recommendations, prompted inclusion of additional material useful to the engineer, the technician, and the student.

While the general arrangement remains unchanged, the present edition has been greatly enlarged and a subject index included. Chapters on transformers and room acoustics have been added. The material on radio propagation and radio noise has been revised. Because of their importance in television, in radar, and in laboratory technique, the data on cathode-ray tubes have been considerably expanded.

The section on electrical circuit formulas has been greatly enlarged; additions include formulas on T- π and Y- Δ transformations, amplitude modulation, transients, and curves and numerous formulas on selective circuits. The attenuator section contains comprehensive design formulas and tables for various types of attenuators. The number of mathematical formulas also has been considerably increased.

The transformer chapter covers classification, temperature, humidity, pressure effects, and general limitations of design as well as actual design data on iron-core transformers and re-

actors. In the room-acoustics chapter are included data on good acoustics, room sizes and proportions for good acoustics, reverberation time, and power levels for public-address requirements.

As revised, the wave-guide chapter includes equations for both rectangular and cylindrical guides plus illustrations of field distribution patterns. Several methods of coupling to the TE_{0,1} mode are illustrated. A table of standard rectangular wave guides and connectors, giving useful frequency range and attenuation, has been added. Design curves for the gain and beam width of rectangular electromagnetic horn radiators are included, and a simple formula for the gain of a paraboloid reflector is given.

The newest method of determining optimum high frequencies for propagation over specific distances is illustrated in the chapter on radio propagation and noise. And the chapter on non-sinusoidal and modulated wave forms, among other additions, includes formulas for amplitude modulation, frequency modulation, and pulse modulation.

In the U.S.A. copies of Reference Data for Radio Engineers, Second Edition, may be ordered from Federal Telephone and Radio Corporation, Publication Department, 67 Broad Street, New York 4, New York, at \$2.00 each or, in lots of twelve or more copies to a single address, at \$1.60 each, postpaid. In other countries, inquiries should be directed to the appropriate associate company as listed on the inside back cover of this journal.

Equations for Generalized Transmission Lines

By SIDNEY FRANKEL

Federal Telecommunication Laboratories, Inc., New York, New York

THE discussion in this paper will be confined to lossless lines. For a two-wire lossless line, the differential equations governing the behavior at points sufficiently far from discontinuities in the line are usually given as

$$\left. \begin{aligned} \frac{\partial V}{\partial Z} &= -L \frac{\partial i}{\partial t} \\ \frac{\partial i}{\partial Z} &= -C \frac{\partial V}{\partial t} \end{aligned} \right\} \quad (1)$$

where V = potential difference between conductors in a transverse plane (volts)

Z = distance along the line in any convenient units

L = inductance in henries per unit length of line, length being measured in the same units as Z

i = current per conductor (amperes)

t = time in seconds

C = capacitance in farads per unit length of line, length being measured in the same units as Z .

In general, a transmission line may consist of more than two conductors and the following general case will be treated:

The line will consist of a multiplicity of conductors of arbitrary cross section which are divided into three groups. Group *A* consists of one or more conductors connected together at one end which end is connected to one terminal of a generator or load. Group *B* consists of one or more conductors connected together at one end which end is connected to the other terminal of the generator or load. Group *C* consists of all other conductors of the uniform line that have no closed circuit through the equipment terminating the line (ground plane, outer shield of two-wire shielded line, etc.). In any transverse plane, the potentials of group *C* conductors are assumed to lie between those of group *A* and group *B*. This insures that when group-*A* potentials are higher than those of group *B*, the induced charges on all group-*A* conductors are positive, and vice versa. Assume further that the total charge per

unit length on the *C* conductor group in any transverse plane is zero. It follows that the total current of these conductors is also zero.

Some examples of this general class are shown in Fig. 1. *A* is a parallel pair near ground excited in such a way that the conductor potentials are balanced with respect to ground. *B* is similar to *A* except that the "ground" conductor surrounds the parallel pair completely. *C* is a so-called "five-wire line" in which the four outside conductors serve as "ground return" for the inner one. *D* is similar to *C* but with only two return conductors. All of these configurations are in practical use.

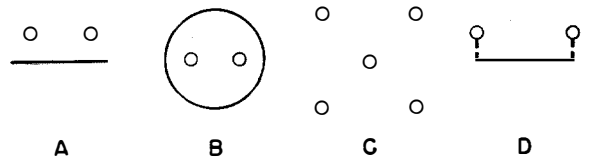

Fig. 1.

The following conventions are adopted: The voltage V will be taken as positive in a transverse plane where the charges on the group-*A* conductors are positive. At the same time the current i will be taken as positive across a transverse plane where the current in the group-*A* conductors is in the direction of increasing Z .

To prove that (1) holds for the general class of uniform lossless lines described above, assume an homogeneous, isotropic (and, of course, lossless) dielectric. Write the field equations for the principal (*TEM*) mode in orthogonal curvilinear co-ordinates (u_1, u_2, Z) with metric coefficients (h_1, h_2, l), so that an element of distance ds is given by

$$ds^2 = h_1^2 du_1^2 + h_2^2 du_2^2 + dZ^2. \quad (2)$$

The electric vector \vec{E} and the magnetic vector \vec{H} lie wholly in transverse planes and are orthogonal. If the u_1 co-ordinates ($u_2 = \text{constant}$) are selected to coincide with the \vec{E} lines, then the u_2 co-ordinates ($u_1 = \text{constant}$) coincide with the \vec{H} lines. \vec{E} has a single component E_1 in the u_1

direction, and \vec{H} has a single component H_2 in the u_2 direction. The field equations are then written

$$\mu \frac{\partial H_1}{\partial t} = 0, \quad (3)$$

$$\frac{1}{h_1} \frac{\partial}{\partial Z} (h_1 E_1) = -\mu \frac{\partial H_2}{\partial t}, \quad (4)$$

$$\frac{\partial}{\partial u_2} (h_1 E_1) = 0, \quad (5)$$

$$-\frac{1}{h_2} \frac{\partial}{\partial Z} (h_2 H_2) = \epsilon \frac{\partial E_1}{\partial t}, \quad (6)$$

$$\epsilon \frac{\partial E_2}{\partial t} = 0, \quad (7)$$

$$\frac{1}{h_1 h_2} \frac{\partial}{\partial u_1} (h_2 H_2) = 0, \quad (8)$$

where ϵ is the dielectric constant in farads per meter, and μ is the permeability constant in henries per meter (mks units). Equations (3) and (7) have been noted previously. Equation (5) states that $h_1 E_1$ is independent of u_2 . As a corollary, it may be stated that $(\partial/\partial Z)(h_1 E_1)$ is also independent of u_2 . Equation (8) states that $h_2 H_2$ is independent of u_1 . As another corollary, it may be stated that $(\partial/\partial Z)(h_2 H_2)$ is also independent of u_1 . These corollaries will be used presently.

If (4) is multiplied by $h_1 h_2 H_2 du_1 du_2$ and integrated over the whole range of u_1, u_2 ,

$$\int_{n_1} \int_{u_2} h_2 H_2 \frac{\partial}{\partial Z} (h_1 E_1) du_1 du_2 = -\mu \int_{u_1} \int_{u_2} H_2 \frac{\partial H_2}{\partial t} h_1 h_2 du_1 du_2. \quad (9)$$

By virtue of the corollaries just stated, the double integral on the left of (9) splits into a product of two single integrals, thus,

$$\left(\int_{u_2} H_2 h_2 du_2 \right) \left(\frac{\partial}{\partial Z} \int_{u_1} E_1 h_1 du_1 \right) = -\mu \int_{u_1} \int_{u_2} H_2 \frac{\partial H_2}{\partial t} h_1 h_2 du_1 du_2. \quad (10)$$

Consider the integral on u_1 in the left member first. The curves $u_1 = \text{constant}$ are orthogonal to the \vec{E} lines by hypothesis and accordingly coincide with the equipotential lines of a transverse plane. Hence, the limits of the u_1 integral are the same as those of the potential, i.e., the

surfaces of the A conductors and B conductors, respectively. The integral on u_1 , being the line integral of the electric intensity, is merely the potential difference between the A and B conductors. Therefore

$$\frac{\partial}{\partial Z} \int_{u_1} E_1 h_1 du_1 = \frac{\partial V}{\partial Z}, \quad (11)$$

the positive sign being used in the right member in accordance with our convention.

For the integral on u_2 in the left member of (10), the interval for u_2 must be found. The curves $u_2 = \text{constant}$ coincide with the \vec{E} lines and consequently with the electric flux \vec{D} lines. The whole net in a transverse plane is thus covered by the totality of \vec{D} (or \vec{E}) lines. But as the sources of \vec{D} lines are the positive charges on, say, the A conductors, exactly complete coverage of u_2 is insured by integrating around all conductors carrying positive charge. But these same conductors carry all of the line current in one direction. The conclusion is therefore

$$\int_{u_2} H_2 h_2 du_2 = i. \quad (12)$$

Here the sign of the integral is correct for a right-handed system of co-ordinates. The right member of (10) may be written

$$-\frac{\partial}{\partial t} \int_{u_1} \int_{u_2} \frac{\mu}{2} H_2^2 h_1 h_2 du_1 du_2 = -\frac{\partial}{\partial t} W_m, \quad (13)$$

where W_m is recognized as the magnetic stored energy per meter of line. By definition for L , this is also $\frac{1}{2} Li^2$; i.e., the right member of (10) may be written

$$-\mu \int_{u_1} \int_{u_2} H_2 \frac{\partial H_2}{\partial t} h_1 h_2 du_1 du_2 = -Li \frac{\partial i}{\partial t}. \quad (14)$$

Substituting (11), (12), and (14) in (10) gives

$$i \frac{\partial V}{\partial Z} = -Li \frac{\partial i}{\partial t}$$

which, except in case $i=0$, is

$$\frac{\partial V}{\partial Z} = -L \frac{\partial i}{\partial t},$$

the first part of (1).

To derive the second equation, a similar procedure is followed, operating now on (6). Multi-

plying (6) by $h_1 h_2 E_1 du_1 du_2$ and integrating over the plane

$$\begin{aligned}
 - \int_{u_1} \int_{u_2} h_1 E_1 \frac{\partial}{\partial Z} (h_2 H_2) du_1 du_2 \\
 = \epsilon \int_{u_1} \int_{u_2} E_1 \frac{\partial E_1}{\partial t} h_1 h_2 du_1 du_2. \quad (15)
 \end{aligned}$$

By similar arguments, the left member is easily seen to be

$$- \int_{u_1} \int_{u_2} h_1 E_1 \frac{\partial}{\partial Z} (h_2 H_2) du_1 du_2 = -V \frac{\partial i}{\partial Z}. \quad (16)$$

The right member is $(\partial/\partial t)W_e$, where W_e is the stored electric energy per meter of line. By defi-

inition for C this is also $\frac{1}{2}CV^2$; i.e., the right member of (15) may be written

$$\epsilon \int_{u_1} \int_{u_2} E_1 \frac{\partial E_1}{\partial t} h_1 h_2 du_1 du_2 = CV \frac{\partial V}{\partial t}. \quad (17)$$

Substituting (16) and (17) in (15) yields

$$-V \frac{\partial i}{\partial Z} = CV \frac{\partial V}{\partial t}$$

which, except in case $V=0$, is

$$\frac{\partial i}{\partial Z} = -C \frac{\partial V}{\partial t},$$

the second part of (1). This completes the proof.

Special Aspects of Balanced Shielded Loops*

By L. L. LIBBY

Federal Telecommunication Laboratories, Inc., Nutley, New Jersey

THE theory of operation of the balanced shielded loop antenna is reviewed. A method of analysis of this type of antenna is described, wherein transmission-line principles are utilized to account for the distributed nature of the loop constants for loops whose perimeters are of the order of one-quarter wavelength. It is shown that the loop conductor within the shield may be treated as a coaxial transmission line having uniformly distributed constants, and that the outer surface of the shield may be treated as a balanced two-conductor transmission line having nonuniform constants. A method is described whereby the relatively cumbersome equations of the latter type of transmission line may be avoided by the use of an "equivalent" line having uniform characteristic impedance. A sample calculation is included to illustrate the utility of this method of analysis.

• • •

Introduction

The balanced shielded loop antenna is widely used in specialized types of radio equipments, e.g., direction finders, homing devices, etc. Its behavior at low frequencies is generally understood and has been covered quite completely in numerous texts on radio and communications. However, the high-frequency behavior of the loop requires further analysis, some of the features of which will be covered in this paper.

The basic principles underlying the operation of this type of antenna are fundamentally the same as those for any other type of antenna. This means that the loop antenna operates so as to satisfy Maxwell's equations at each and every infinitesimal point in space, whether this be a point on the loop-shield surface, within the shield conducting material, or anywhere in the dielectric medium surrounding the loop antenna. Strictly speaking then, the complete electromagnetic field, including all retardation effects,

must be considered in analyzing the behavior of the loop antenna at high frequencies. However, it is often possible to take advantage of the analytical simplifications afforded by the use of conventional circuit theory, as will be shown.

In the discussion which follows, the analysis will be restricted to the case of a single-turn, balanced, shielded loop wherein an inner conductor is positioned within a shielding tube of highly conductive nonferrous material such as copper, aluminum, or brass. The conductivity is considered great enough so that the so-called "depth of penetration" of current and field is less than 10 percent of the wall thickness of the tubing, thus ruling out any interaction between current on the outside of the shield and current on the inside of the shield. This restriction represents the usual case for shielded loops. A further restriction is made in that the half-perimeter ($P/2$) of the loop shield is not to exceed a length equal to $1/4$ the free-space wavelength (i.e., 90 electrical degrees) of the highest frequency under consideration, thus ruling out cases where the loop-shield current may undergo a reversal of phase and hence complicate the analysis. Such a loop antenna is shown diagrammatically in Fig. 1, wherein the inner conductor $ABCD$ is contained within the outer shield EFG . Although this loop is pictured as being circular, the analysis applies equally to other commonly encountered shapes such as square, diamond, and rectangular with long axis vertical. The rectangular loop with long axis horizontal tends to act like a folded-dipole antenna, and therefore will not be considered in this discussion.

In accordance with the theory of symmetrical balanced circuits, the vertical axis $N-N'$ of the loop is the line of intersection between a virtual infinite equipotential plane and the plane of the loop. This virtual infinite plane is, of course, perpendicular to the plane of the loop. Thus, the balanced loop behaves the same as any other balanced or "push-pull" system, and it is possible to consider any point whose physical position coincides with the virtual equipotential plane to

* Reprinted from *Proceedings of the I.R.E. and Waves and Electrons*, v. 34, n. 9; September, 1946.

be at reference ground potential. (An implication contained in the above statement is that the axes of physical symmetry and electrical symmetry of the loop are the same.) Therefore, points *F* and *H* and the point on the inner conductor midway between points *B* and *C* may all be considered to be at reference ground potential. The half-perimeter of the loop is represented by $P/2$, this distance being measured along the center line of the shield tubing.

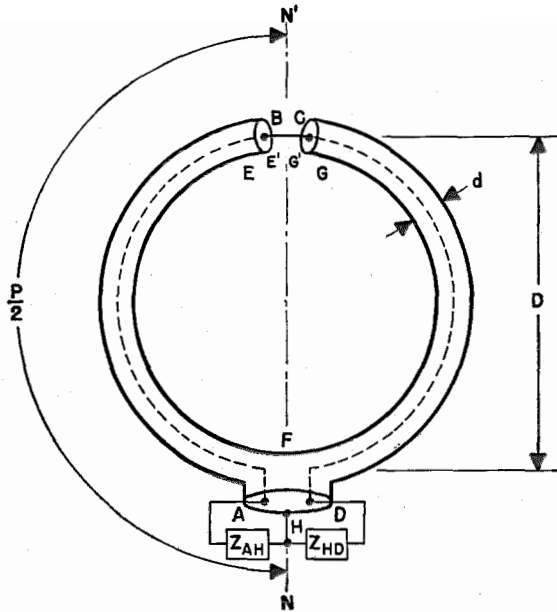

Fig. 1—Single-turn balanced shielded loop antenna.

Basic Principles of Operation

The shielded loop receives energy from a vertically polarized, horizontally propagated electromagnetic wave by the following process:

The propagated field induces electromotive forces on the outside surface of the shield, along each of its legs, but induces none on the inside surface of the shield nor on the inner conductor, since the depth of penetration of the field is much less than the thickness of the shield material.¹ This fact, incidentally, permits us to treat phenomena on the outside surface of the shield independently from phenomena on the inside surface of the shield. Thus, for example, points *E* and *G* on the edge of the loop shield (Fig. 1)

¹ S. A. Schelkunoff, "Electromagnetic Waves," D. Van Nostrand Company, Inc., New York, N. Y., 1943, Chap. 4, p. 89.

may be considered to be associated only with currents and impedances on the outside surface of the loop shield, whereas points *E'* and *G'* (actually the same points as *E* and *G*) may be considered to be associated only with currents and impedances on the inside surface of the loop shield. It should be noted that this inside surface of the shield and the inner conductor of the loop form a coaxial transmission line, a fact which will be made use of later in the analysis.

The electromotive forces induced along the outside surface of the loop-shield legs cause current to flow thereon and produce a resultant voltage V_{EG} across the shield gap *EG* (or *E'G'*). This gap voltage is thus impressed across the points *E'B*, *BC*, and *CG'* in series, so that the resultant voltages appearing across these individual points (*E'B*, *BC*, and *CG'*) will be proportional to the impedances existing between them. This may be understood by referring to Fig. 2, which shows the equivalent circuit of the loop-shield and gap impedances. This method of analysis has been presented in a previous paper.²

Evaluation of Loop Impedances

It is obvious that for small gaps the impedance between points *B* and *C* is negligibly small, since it is composed of the inductive reactance of but a very short length of connecting wire. As a consequence, the loop-shield-gap voltage can be considered as being impressed only across impedances $Z_{E'B}$ and $Z_{CG'}$, in series, resulting in voltages $V_{E'B}$ and $V_{CG'}$. These voltages will be

² N. Marchand, "Complex Transmission Line Network Analysis," *Electrical Communication*, v. 22, n. 2, pp. 124-129; 1944.

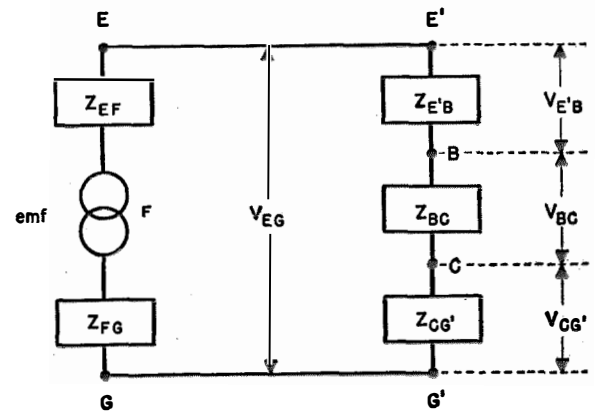

Fig. 2—Equivalent circuit of shield and gap impedances.

equal if the corresponding impedances are equal. The impedances will be equal if the two coaxial transmission lines, formed by the two legs of the loop shield surrounding the inner conductor, are equal in Z_0 , in electrical length, and in terminating impedances Z_{AH} and Z_{HD} .

Thus, referring to Fig. 3, we can see that the evaluation of the impedances $Z_{E'B}$ and $Z_{CG'}$ is resolved into the comparatively simple problem

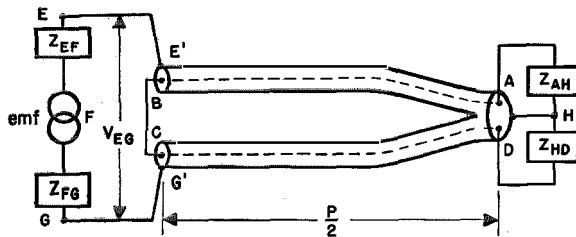

Fig. 3—Modified equivalent circuit showing coaxial lines.

of solving the well-known equation for the input impedance of a transmission line of known termination. One convenient form of this is

$$Z_{IN} = Z_0 \frac{1 + \rho / -2\theta}{1 - \rho / -2\theta} \quad (1)$$

where Z_0 = characteristic impedance of the coaxial line formed by the loop conductor within the shield,

θ = electrical length of the line in degrees,

and

ρ = reflection factor.

The reflection factor ρ is given in turn by the equation

$$\rho = \frac{Z_L - Z_0}{Z_L + Z_0} \quad (2)$$

where Z_L is the terminating impedance of the line, represented by the impedances Z_{AH} and Z_{HD} in the illustration.

As a further simplification of the analysis, it is convenient to make use of the fact that the magnitude and phase angle of the impedance of any two-terminal network is unaffected by the order of connection of the terminals of this network into any circuit. This allows us to substitute Fig. 4 for Fig. 3, wherein terminals B and C of the coaxial transmission lines have been interchanged respectively with terminals E' and G'. This interchanging of terminals, applying as

it does only to phenomena associated with the inner surface of the loop shield, in no way affects the action of the outer surface of the shield with respect to the impedances Z_{EF} and Z_{FG} . It allows us to treat the two coaxial sections as two halves of a conventional balanced transmission-line system in which the shields are connected together, rather than separated.

The evaluation of the impedances Z_{EF} and Z_{FG} of the outside surface of the loop shield is comparatively simple at the lower radio frequencies (i.e., at frequencies where $P/2$ is less than 10 electrical degrees) since the current along the length of the shield is then substantially constant in amplitude and phase. This allows us to calculate the inductance of the outer shield, and also the radiation resistance, using standard formulas. The inductance for the case of a circular loop carrying current of constant amplitude and phase is given to a close approximation by the expression (referring to Fig. 1)

$$L = 0.01595D \left(2.303 \log_{10} \frac{8D}{d} - 2 \right) \text{ microhenry,} \quad (3)$$

where D and d are in inches, and the radiation resistance for this same case is given by the approximate expression,

$$R = 31,000 \frac{A^2}{\lambda^4} \text{ ohms,} \quad (4)$$

where A is the area enclosed by the loop-shield center-line in square meters and λ is the wavelength in meters.

Examination of (4) shows that the radiation resistances of the loop shields considered above are of the order of 0.002 ohm or less, and as such are negligible compared to the corresponding inductive reactances. The impedances Z_{EF} and Z_{FG} are thus substantially pure inductive re-

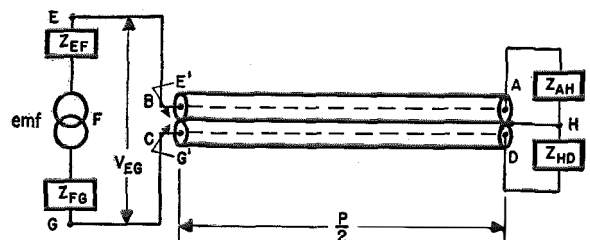

Fig. 4—Simplification of transmission-line connections.

actances at low radio frequencies, and the equivalent circuit in Fig. 4 becomes that shown in Fig. 5.

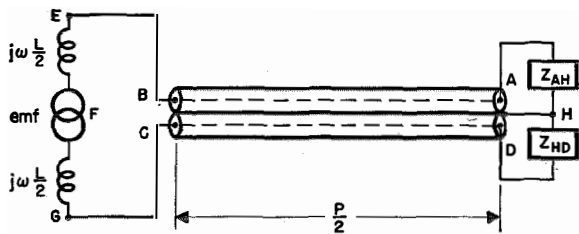

Fig. 5—Low-frequency condition corresponding to Fig. 4.

The value of L referred to in this figure is that calculated from (3), and the electromotive force of the generator shown is obtained from the expression

$$\text{electromotive force} = h_e \mathcal{E} \text{ volts,} \quad (5)$$

where \mathcal{E} is the field strength of the received wave in volts per meter, and h_e is the so-called effective height of the loop shield in meters, it being assumed above that the horizontal direction of propagation of the wave is in the plane of the loop.

The effective height h_e is given in turn by the following equation for a single-turn loop,

$$h_e = 2\pi A / \lambda, \quad (6)$$

where A and λ are the same as for (4).

For the higher radio frequencies, the evaluation of the impedances Z_{EF} and Z_{FG} and of the total induced electromotive force becomes a somewhat more difficult problem than for the low-frequency case, since the current distribution along the shield can no longer be considered uniform. The current distribution is closely sinusoidal, having a maximum value at the base of the loop shield and dropping off in each leg as the gap position is approached. As a consequence, the loop shield tends to behave like a section of balanced transmission line, but not of uniform characteristic impedance. This nonuniformity of characteristic impedance is obviously a result of the fact that the current in each element of length of one leg of the loop shield is not fixed in distance and/or direction with respect to the oppositely flowing current element in the other leg of the loop shield. Because of this, relations which apply for uniform transmission lines do

not apply in their regular sense for voltages, currents, and impedances involved on the outside surface of the loop shield. A quantitative analysis of the induced electromotive-force relationships is beyond the scope of this paper; but an analysis of impedance values is given below which should aid in establishing a picture of what takes place.

Referring to Fig. 6, the loop shield may be considered to comprise a two-conductor balanced transmission line of nonuniform characteristic impedance wherein each leg of the loop shield is a conductor of this transmission line, and the spacing S_x between conductors is a function of the distance x from the gap, as is the angle ϕ_x between the conductors (and between their currents I_x and I_x') at this point. It is evident from the figure that the terminating impedance of this nonuniform transmission line is zero, since at the point where the distance x becomes equal to the diameter of the loop the two conductors join to form a short circuit, and the shield current I becomes a maximum. In attempting to obtain the solution for the input impedance of such a transmission line, one usually encounters some rather cumbersome mathematical expressions which tend to make this work laborious. As a consequence, the writer has developed an approximate expression, verified

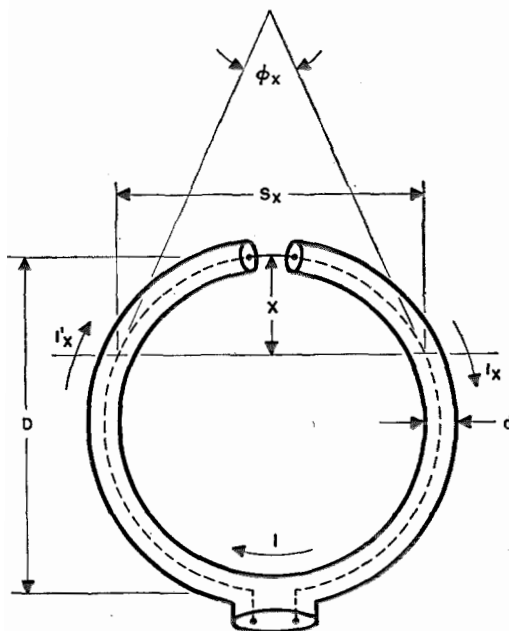

Fig. 6—Loop shield considered as a nonuniform transmission line.

empirically for a number of different cases, which greatly simplifies the problem of evaluating the above impedances. This empirical relation may be obtained from the following considerations.

The loop-shield configurations discussed above may be reduced to an equivalent uniform transmission-line section by postulating that:

- a. The length of this transmission-line section be equal to the half-perimeter ($P/2$) of the loop shield.
- b. The conductors of this transmission line be of the same cross-sectional dimensions as the legs of the loop shield.
- c. The mean spacing between these conductors be such that the mean area of this equivalent transmission-line section be equal to the mean area of the loop shield.
- d. The transmission-line section be perfectly short-circuited at its far end.

By applying these rules, we get the transmission-line configuration shown in Fig. 7 as the

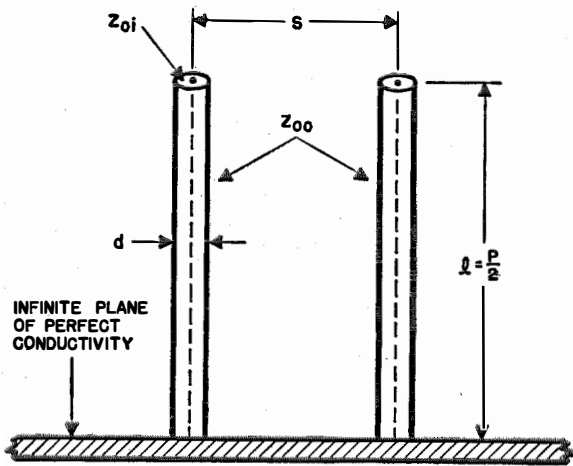

Fig. 7—Transmission-line section equivalent to the loop shield of Fig. 6.

equivalent of the loop-shield configuration of Fig. 6, and it is now possible to calculate the characteristic impedance of this transmission-line section by using the well-known relation (referring to Fig. 7),

$$Z_0 = 276 \log_{10} \frac{2S}{d} \tag{7}$$

This effective characteristic impedance of the loop shield we shall designate as Z_{00} to distinguish

it from the characteristic impedance of the "inner" transmission line referred to in (1), which we shall now designate as Z_{0i} .

We may now draw the equivalent transmission-line network, Fig. 8, which is applicable to our problem for the high-frequency condition. This problem has now been reduced to the relatively simple case of a composite transmission-line system, the solution for the voltages, currents, and impedances of which may be obtained in the usual manner. As a matter of note, the transmission-line network of Fig. 8 may be employed for the low-frequency solution also, since the relationships and equivalences established therein do not depend on frequency. Thus, calculating the inductance of the loop shield by means of the well-known equation for the input impedance of a section of short-circuited lossless transmission line,

$$Z_{IN} = jZ_0 \tan \theta, \tag{8}$$

we get for the inductance

$$L = \frac{Z_{IN}}{j\omega} = \frac{1}{\omega} Z_0 \tan \theta, \text{ henry} \tag{9}$$

and we find that this gives a value for the loop-shield inductance which is within a few percent of that given by (3), thereby helping to verify the validity of the "equivalent transmission-line" method of analyzing loop-shield impedances.

Numerical Example

An example of how the above principles for evaluating the loop impedance components may be applied in finding the resonant frequency of a typical shielded-loop structure is given below.

Referring to Fig. 1, suppose that the following values are chosen:

- mean loop diameter $D = 12$ inches,
- outside diameter of shield tubing $d = 1$ inch,
- inside diameter of shield tubing $d' = 0.9$ inch,
- diameter of inner conductor $d'' = 0.064$ inch,
- and loop load impedances $Z_{AH} = Z_{HD} = \infty$ (i.e., open circuit).

Solving for the spacing S of the equivalent transmission-line section (Fig. 7), we get

$$S = \frac{A}{P/2} = \frac{\pi(D/2)^2}{\pi(D/2)} = \frac{6^2}{6} = 6 \text{ inches.} \tag{10}$$

The characteristic impedance of this section is then

$$Z_{00} = 276 \log_{10} \frac{2S}{d} = 276 \log_{10} 12 = 298 \text{ ohms. (11)}$$

The characteristic impedance of each inner coaxial line is

$$Z_{0i} = 138 \log_{10} \frac{d'}{d''} = 138 \log_{10} 14 = 158 \text{ ohms. (12)}$$

The half-perimeter $P/2$ is given by

$$P/2 = \pi(D/2) = 6\pi = 18.9 \text{ inches} = 0.48 \text{ meter, (13)}$$

so that the corresponding electrical angle in degrees is (assuming air dielectric throughout),

$$\theta = \frac{(0.48)(360)}{\lambda} = \frac{173}{\lambda} \text{ degrees. (14)}$$

Since both the outside transmission-line section and the inside transmission-line section are equal in electrical length for this case, we may write

$$\theta_0 = \theta_i = \theta. \quad (15)$$

The total electrical length of the transmission-line network θ_T would then be the sum of θ_0 and θ_i if the characteristic impedance Z_{00} were equal to twice the characteristic impedance Z_{0i} . Since such is not the case, we must obtain the equivalent electrical length, θ_{eq} of the outside transmission line with respect to the inner transmission lines. This is obtained by equating the impedance to the left of BC (Fig. 8) in terms of Z_{00} to the same impedance in terms of twice Z_{0i} , whereby,

$$jZ_{00} \tan \theta_0 = 2jZ_{0i} \tan \theta_{eq}, \quad (16)$$

which then yields

$$\begin{aligned} \theta_{eq} &= \arctan \frac{Z_{00} \tan \theta_0}{2Z_{0i}} \\ &= \arctan \left(\frac{298}{316} \tan \frac{173}{\lambda} \right) \end{aligned} \quad (17)$$

and then θ_T may be obtained from

$$\theta_T = \theta_i + \theta_{eq} = \frac{173}{\lambda} + \arctan \left(0.944 \tan \frac{173}{\lambda} \right). \quad (18)$$

To obtain the lowest frequency at which this transmission-line network goes through reso-

nance, i.e., the frequency at which the reactive component of the impedance across terminals A and D becomes zero, we set θ_T equal to 90 degrees and solve for λ . This is done by first transforming (18) to

$$\begin{aligned} \tan \theta_T - \tan \frac{173}{\lambda} &= 0.944 \tan \frac{173}{\lambda} \\ &+ 0.944 \tan \theta_T \left(\tan \frac{173}{\lambda} \right)^2. \end{aligned} \quad (19)$$

Then, dividing through by $\tan \theta_T$ to get rid of some undesirable infinities, and setting θ_T equal to 90 degrees this expression reduces to

$$\tan \frac{173}{\lambda} = \sqrt{\frac{1}{0.944}} = 1.030 \quad (20)$$

whereby

$$\lambda = \frac{173}{\arctan 1.030} = \frac{173}{45.85} = 3.78 \text{ meters, (21)}$$

so that the resonant frequency is

$$f = \frac{300}{\lambda} = 79.4 \text{ megacycles. (22)}$$

Actual measurements of the resonant frequencies of shielded-loop structures similar to the one calculated above indicate that the calculations give values accurate within 5 percent. This again helps to verify the validity of the "equivalent-transmission-line" method of analyzing loop-shield impedances.

Conclusions

It is to be concluded that the balanced shielded loop antenna may be analyzed by the

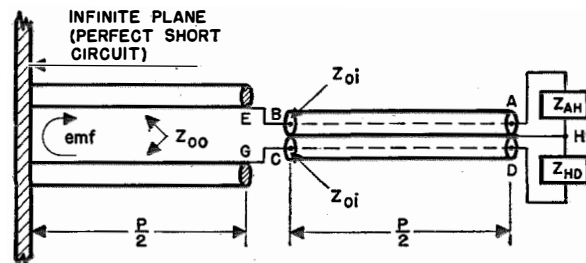

Fig. 8—High-frequency condition corresponding to Fig. 4 and incorporating the equivalent transmission-line section for the loop shield.

use of conventional transmission-line theory; and if the simplifications introduced in this paper are utilized, the amount of labor in making such an analysis is greatly reduced.

The method of analysis may be extended to

include cases wherein certain compensating impedances are introduced between points *B* and *C* and across points *E* and *G* (Fig. 1) of the loop, it then being necessary merely to include these impedances at the appropriate points in Fig. 2.

Errata, Vol. 21, No. 1, 1942

THE CURRENT RATING OF PAPER INSULATED POWER CABLES

Page 33, line 3: Equation should be

$$P = tk/2rk_s \text{ instead of } P = tk/3(2rk_s).$$

Fig. 4: $P = tk/2rk_s$ instead of $P = tk/6rk_s$.

Page 34, Formula (XIII): Numerator should be 0.024 instead of 0.24.

Page 39, line 12: Numerator in formula should be 45 instead of 50.

Electrical Communication: 1940-1945

War Years' Review—Part III

Editor's Note: This final installment of the War Years' Review presents contributions of additional International Telephone and Telegraph Corporation associate companies active in various branches of the electrical communication field. Part I highlighted the activities of Standard Telephones and Cables Ltd. (London) and Standard Telephones and Cables Pty. Ltd. (Sydney); Part II was devoted to the Federal Telecommunication Laboratories (New York, New York) and Federal Telephone and Radio Corporation (Newark, New Jersey).

AMERICAN CABLE AND RADIO CORPORATION, NEW YORK, NEW YORK

FROM the very start of hostilities in the fall of 1939 when ears were glued to radio loudspeakers for the latest bulletins, it was evident that communications would play a most important role in World War II. That wire and radio communications proved the life lines of many of the far-flung global operations of the war is now history. It is almost superfluous, therefore, to state that the contributions of the record communication companies of the American Cable and Radio System, Inc.,¹ to the war were outstanding and numerous.

Even before Pearl Harbor, many of the problems of conversion that would be necessary to meet wartime communications had been studied and worked out. This work was done in cooperation with the Defense Communications Board (later named the Board of War Communications) and carried out in such a manner that transition to war status, with its greatly increased technical and operating problems, including the activities of censorship, priorities for messages, and administration, was accomplished in an orderly manner and with a minimum of difficulty.

All America Cables and Radio and the Commercial Cable Company provided communication facilities to the Allied Forces for the quick transmission of weather reports in the North Atlantic and Caribbean all during the war. This service was invaluable to the Air Transport Command and the Navy and made the proper coordination of their missions possible. A special

leased circuit was provided by the Commercial Cable Company between Maine and Newfoundland which was used by the United States Army, the Royal Canadian Air Force, and the Royal Canadian Navy for dispatching airplanes across the Atlantic and for weather reports. Similar special circuits were set up by All America Cables between Naval Headquarters at New York and San Juan, Porto Rico; Guantanamo Bay, Cuba; and the Canal Zone.

In addition to these special circuits, the cables of the two I.T.&T. System companies which connect North America with Central America, West Indies, South America, and Europe carried record traffic loads.

The equipping of several cables with teleprinter operation made possible the rendering of additional important war services. This expansion was particularly valuable in the North Atlantic defense area. Upon the occupation of France and the low countries, cable connections severed at the start of the war were speedily re-established.

The *John W. Mackay* and the *Marie Louise Mackay*, I.T.&T. System cable ships, were chartered for use by the United Nations military forces throughout the conflict. The *John W. Mackay* was assigned the important and hazardous mission of establishing and laying a long stretch of cable in the Persian Gulf. When this cable was completed, it was directly instrumental in providing secret communications for the Allies in the Persian Gulf theater of warfare which was an important factor in their aid to Russia. Another and even more hazardous assignment of the *John W. Mackay* was one directly

¹ Comprised of Mackay Radio and Telegraph Company, Commercial Cable Company, All America Cables and Radio, Inc., and Sociedad Anónima Radio Argentina.

under the Axis guns in the English Channel. While actually under fire, the *John W. Mackay* diverted a transatlantic cable into Cherbourg shortly after the Normandy landings. With this cable in operation, the government was able to handle many important communications directly between France and the United States.

Throughout the entire war, the *Marie Louise Mackay* was engaged in cable repairs in United Kingdom areas, the North Atlantic, the Azores, and the Mediterranean.

Although their world-wide network of communications facilities was heavily taxed by the shift from normal peacetime commercial traffic to abnormal war requirements, these I.T.&T. System communications companies were able to provide a link between the soldier at the front and his loved ones at home that served as a morale builder whose value can hardly be estimated. This link was the Expeditionary Forces Message which permitted almost instantaneous personal contact between the battle front and home front at a nominal rate. Expeditionary Force Messages, or EFM's as they were called, were an adaptation of the technique worked out years before for the handling of congratulatory or other messages following a standard word pattern, only the EFM was fitted to the needs of the combat troop. Since wording of these messages was fixed, they simplified censorship problems and reduced the total use of communication facilities.

Specific wartime activities required the use by Allied Governments of cable and radio facilities on both full-time and part-time bases. The Commercial Cable Company provided direct facilities between London and New York and Washington to the various Allied governments. Over these circuits many thousands of important war messages were handled. In addition, fully staffed international radio communication stations both fixed and mobile, were provided in war-theater centers to handle press, general, and soldier messages to and from the U. S. A.

The first of the fixed stations was set up in Algiers in the wake of the North African invasion. It provided the only direct outlet to the U.S.A. for press correspondents following the Tunisian, Sicilian, and early Italian campaigns.

The second fixed station was established in Paris after the Normandy invasion.

Most famous of the mobile stations, known as "Station 25," was landed on the Normandy beach head shortly after *D* Day and accompanied General Patton's Third Army in its history-making drive across France. The transmitter was a 1-kilowatt, stationary Army set adapted for mobile service. To keep up with General Patton's sensational rush across western Europe, it was necessary to dismantle and re-erect this station some 25 times. Operation was often carried on under enemy fire, but in spite of extremely adverse conditions, thousands of dispatches which included press material and EFM's were handled. It was this station that provided the headlines the American people prayerfully read as they followed the progress of the crucial invasion.

Success of Station 25 was in a great measure due to the dogged determination of the small, but courageous, staff to get the messages through in spite of all obstacles. Its crew was made up of carefully selected Mackay engineers, technicians, and operators chosen from the more seasoned long-time employees. They were men who could be relied on to know how to do a job and to do it quickly and carefully, even under enemy fire.

As originally planned, Station 25 was to be equipped with a 15-kilowatt transmitter built especially for it by the Federal Telephone and Radio Corporation. Before being shipped to England, this station was assembled at a point on Long Island and given thorough trials by the personnel chosen to operate it in the invasion. Then it was dismantled and crated for the ocean voyage. In England, further trials and training of the personnel continued. Unfortunately, a change of plans at the last minute of the invasion made it necessary to leave behind the higher-powered equipment and substitute the 1-kilowatt transmitter. Without the equipment with which they had been trained and subjected to the severe beach-head battle conditions, the Mackay crew functioned like veteran troops to open the circuit.

Station 25 arrived in Paris on July 26, 1944, one day after the Army. While Station 25 continued on with Patton's forces, Mackay personnel returned to the Normandy beach to find the 15-kilowatt equipment left behind. Although

some of the cases containing important components were never found, enough were salvaged from dumps along the beach head to permit a complete overhaul. This took place in Paris with the help of Le Matériel Téléphonique, and on October 17 the 15-kilowatt station was placed in operation for direct communication service from Paris. After hostilities ceased, Station 25 was set up at Nuremberg from whence it is now providing direct service to New York handling press dispatches concerning the war-crime trials.

Altogether, three portable truck radio units were completely outfitted and staffed by Mackay Radio for the European theater of operations. Besides Station 25 with the Third Army, one was assigned to the 9th Air Force, and one was subsequently located in Berlin.

In addition to supplying these field units, Mackay Radio also assisted the Government in other ways. The radio stations which the company formerly maintained near Chicago, Illinois, and New Orleans, Louisiana, were taken over by the Army, while the Navy leased the Mackay Radio station near Seattle, Washington, and purchased the station near Washington, D.C.

High-power radiotelegraph transmitters under direct Government control were leased at various of the company's stations in the U.S.A. to the United States Army and Navy as well as to the Office of War Information. Certain stand-by facilities for emergency use were also provided and kept activated continuously throughout the war period. Altogether, 30 new radiotelegraph circuits were inaugurated by Mackay Radio during the four years following the commencement of war.

Mackay Radio also took part in an episode of top secrecy in connection with the War of the Pacific. On December 31, 1941, the United States Army ordered Mackay to blow up its station in Manila. This was the transmitting station LP at Las Pinas and the receiving station AL at Aliban, both about 25 miles south of Manila. The famous last words of LP, "Good bye, we are now demolishing," were heard by Mackay operators along the west coast. Manila was cut off from the Allied world. But shortly after the fall of Bataan extremely weak, unidentifiable, radio signals were picked up at KFS, the company's coastal station near San Francisco,

California. After determined and prolonged efforts on the part of the KFS personnel, reception of the signals was improved to the point where they could be identified. Contact was established and the signals were found to be coming from a station located on Luzon. This station had been put together from odds and ends gathered by the Philippine guerilla forces. Once contact was established, it was maintained throughout the remainder of the war. From this source General MacArthur was provided with vital information about the strength and disposition of Japanese forces, thus aiding the invasion when the hour of Leyte finally arrived.

The Commercial Cable Company and Mackay Radio and Telegraph Company were awarded Certificates of Appreciation by the War Department for loyal and patriotic service rendered the Signal Corps.

Based on much of the experience gained from meeting these wartime problems, plans for U.S.A. radio operations now call for improvement and enlargement of multichannel very-high-frequency radio control systems between city operating rooms and radio stations, together with application of improved frequency-shift techniques and printer operation to major transoceanic circuits, with multiplex facilities where required.

Another result of wartime operation is the establishment by the major radio communication companies of the U.S.A., of radio relay stations in the International Zone in Tangiers. It is expected that these relays will help maintain circuit operations during periods when more direct routes are interrupted by atmospheric or other disturbances.

Mackay Radio's extensive coastal station services with ships rendered by four stations on the Atlantic coast and three on the Pacific coast were largely suspended during the war for security reasons, except for traffic of ships of neutral nations. WSA at New York, KFS at San Francisco, and KEX at Portland, Oregon, were leased to the United States Coast Guard in 1942. Most of the radio operators of these stations entered the Coast Guard and continued in coastal station service. Under the direction of the Coast Guard, the company made an enviable contribution to the war effort in connection with safety service to war shipping and later for air-sea rescue operation, particular in the great job

of transporting troops from Europe to the Pacific and subsequently on their return home.

Prior to the war, radio equipment on approximately 300 ocean-going United States vessels was licensed to and maintained by the Marine Division of Mackay Radio. Entry of the U.S.A. into the war, with its tremendous increase in shipping, involved an abnormal program of installation and maintenance of marine radiotelegraph and radio direction-finding equipment. By November, 1945, apparatus had been installed on well over 3000 vessels, of which approximately 1700 were equipped with the FTR console unit.² This complete ship's radio station in a single assembly, which may be easily installed and its power lines plugged into the ship's mains, is an important advance in design which proved of particular value in ship construction because it made possible a considerable saving in vital time.

Over 1600 radio stations on ocean-going vessels are presently maintained under contracts with nearly all steamship companies and the War Shipping Administration. These ships' stations are all licensed to Mackay Radio.

Equipment was also installed and maintained on hundreds of other Allied Nations' vessels which called at U.S.A. ports. Well over 5000 radio direction finders were calibrated by Mackay engineers on these ships.

The coastal stations were released to the company January 1, 1946, coincident with the lifting of wartime restrictions on commercial ship message traffic. Their facilities are now being amplified and new coastal stations will be added.

In the light of the tremendous number of ships of the world equipped during the war with radiotelegraph apparatus, particularly of high-frequency type, and visualizing that peacetime ship traffic will ascend to a new high, U.S.A. communication companies have evolved a unified plan³ for world maritime radio operations.

² E. J. Girard, "A New Marine Radio Unit for Cargo Vessels," *Electrical Communication*, v. 20, n. 2, pp. 71-72; 1941.

³ A copy of this plan may be obtained from Mackay Radio and Telegraph Company, 67 Broad Street, New York 4, New York.

This plan proposes to meet the problems of congestion likely to arise during the postwar period. Many such problems have already arisen since commercial ship radio operation was restored at the beginning of 1946.

The proposal provides for planned communication in the maritime field where space in the frequency spectrum is allotted to the various types of service on a scientific basis considered sound both from the technical and operating viewpoints.

Briefly, the following are salient points of the plan:

- A. Harmonic relationship of all high-frequency ship radiotelegraph bands.
- B. Crystal-controlled transmissions from all radio-equipped commercial vessels.
- C. Transmitting equipment embodying quick change-over from calling to working frequencies.
- D. Separate "areas" in the high-frequency ship telegraph bands for passenger and cargo vessels. (This division is recommended because passenger vessels provide many forms of radio service and are in general "heavy-traffic" vessels by comparison with cargo ships.)
- E. More stringent regulation of equipment and higher technical standards for passenger vessels as compared to cargo.
- F. Better engineering practices to provide greater utilization of the high-frequency bands and care for the sharp increases in world shipping, thus avoiding allocation of additional frequencies. (Provision is also made in the plan for commercial traffic to and from aircraft as air routes become better established.)

An orderly realignment of the vital radio links between coastal stations and maritime mobile units, which play such an important part in the safety of life and property at sea, has long been recognized as desirable. It is apparent that the new proposal contains many elements of merit that would go far to improve and modernize this service.

INTERNATIONAL MARINE RADIO COMPANY, LTD., LIVERPOOL, ENGLAND

Following the outbreak of war, demands on I.M.R.C.'s services grew steadily and volume of installation and maintenance work rose nearly tenfold. Proportionally the staff increase was small. Manpower was Britain's problem. The Armed Forces and the vital war factories came first and I.M.R.C.'s choice of additional shore staff was confined to older or sick and war-disabled men. Nevertheless, undeterred by bombings, submarines, mines, and enemy ships, its gallant staff performed its arduous tasks on land and sea with perseverance and dispatch.

Commencing with seven home service depots in full operation in September, 1939, nine subsidiary depots were opened up and down the coasts. Primarily to meet Admiralty demands, these depots covered the installation of radio-telephone equipment in small craft—tugboats, yachts, drifters, and trawlers, all of which were pressed into naval service at the outbreak of war and achieved their greatest glory in the evacuation of Dunkirk.

The tragic example of the *Athenia*, lost on the first day of war, emphasized the urgent need for improving means for saving life at sea, and the Ministry of War Transport called on the wireless companies to produce a small automatic transmitter. It was intended for the use of seamen adrift in life-boats and also for small craft in the North Sea to enable them to give warning of attacks by aircraft.

For this purpose the I.M.R.C. type TG.5-A transmitter, fitted in coasters with gratifying results, was modified. It was coded as the TG.5-B and was for three years the only approved life-boat transmitter. Orders for this equipment came in thick and fast. Many are the seamen who owe their lives to it.

The Air Ministry, anxious to provide means of communication for distressed bomber crews adrift in dinghies, approached I.M.R.C. for a suitable portable transmitter. The TG.5-B was modified and became the TG.5-C—the first dinghy transmitter of the war.

Air-sea rescue floats, based around the coast, also were equipped with TG.5-C portable transmitters. Thus, airmen brought down into the sea could send distress signals in code to the Rescue Service.

Today, incidentally, the TG.5-B has been retired from active service and replaced by the IMR.45—I.M.R.C.'s latest contribution to safety of life at sea—for which an initial order of 1000 was placed by the Government. It is now a compulsory fitting in all of the British mercantile marine and in some Allied vessels.

September, 1942, saw the first tests of what was then the latest improvement in life-boat radio—the rocket-kite aerial. Following a request from the Ministry of War Transport for increased range in the TG.5-B transmitter, in order that distressed seamen could communicate with America or with Britain at any point of the Atlantic, a great deal of work was done on this transmitter. The final decision was that the answer lay in the aerial.

Balloons and hand-flown kites were tried and rejected as unreliable. The Ministry of Aircraft Production, wrestling with an identical problem, invited I.M.R.C. to attend secret tests, the outcome of which was the rocket-kite aerial equipment, whereby a rocket was fired from a signal-light pistol carrying a self-opening kite and 200 feet of flying line to which the aerial was afterwards attached. Tests showed astonishing results: the small life-boat transmitter gave performance equal to high-powered equipment and all British coast stations reported signals in good strength. Nearby stations, in fact, requested that power be reduced, certain proof, if proof were needed, that the answer to the Government's call for increased range had been met.

The part played by the rocket-kite aerial in World War II has been called as revolutionary as that of the paravane in the last war. With it, the portable transmitter obtained a range of about 800 miles. Its true value is summed up by the Government in the official notice to seamen concerning the operation of life-boat equipment: "Read this carefully. Your life depends upon it."

The Raft-o-Lite, flashing the SOS signal in Morse continuously for 48 hours, was introduced for use at night. Based on an idea put forward by an I.M.R.C. engineer who had had experience with similar lights used for whaling, the Raft-o-Lite served a dual purpose: it guided towards the raft men who had been struggling blindly in the water, and it attracted the attention of passing

ships or aeroplanes. Being entirely automatic, it started signalling as soon as it was thrown into the water, stopping only when it was lifted out—a very important feature to men too numbed with cold to turn a switch.

The type TW.1 hand pump followed. Balers, used previously, had proved inefficient. Seamen weakened by exposure, often wounded or frost-bitten, could not keep pace with the inrush of water into lifeboats frequently holed by machine-gun bullets. I.M.R.C.'s hand pump was simple and light; clamped to the gunwale of the boat, it could easily be handled by one man, yet did the work of several men using balers. Forethought for the half-frozen and weakened seamen produced the pump's quick-release cover, which enabled a man with numbed fingers to open the pump if necessary without having to turn screws or use tools.

It had been found by the Government that submarines were taking bearings on convoys from the radiation of ships' receivers on watch and immediate steps were requested to suppress all such radiation. Within 24 hours the problem was solved. The SR.1 suppressor unit was evolved by I.M.R.C. and put into manufacture, deliveries commencing within six weeks.

The emergency aerial, to be used in the event of the main aerial being damaged or destroyed, was also called for by the Government. I.M.R.C. pioneered in this type of equipment.

Two types of hand-driven generators were evolved, one for operating the TG.5-B or other life-boat transmitters and the other to recharge the battery and simultaneously operate a signalling lamp at the life-boat's masthead. These generators, manufactured for I.M.R.C. by Campbell & Isherwood Limited, were supplied in quantity to the Norwegian Shipping and Trade Mission in Great Britain, and the principle was standardized by the Ministry of War Transport for use with all life-boat transmitters.

And, finally, all I.M.R.C. chief radio officers were provided by the Company with Morse signalling torches for emergency use.

The mighty "Queen Elizabeth," born to the royal purple, destined to be Queen of the Atlantic, was robbed of her regal trappings and fitted out as a troopship. With temporary radio equipment installed by I.M.R.C., she sailed on

her first voyage, arriving in New York on March 7th, 1940. Additional temporary radio equipment was shipped to New York and installed by Mackay Radio & Telegraph Company. From America she went to Australia and to Singapore and, in June 1942, she returned to England where her radio station was fitted in a matter of six days, and a senior I.M.R.C. engineer was left on board for a voyage to ensure that the radio personnel were fully conversant with the intricacies of the vast installation. This was a radio station that would have taken at least six weeks to fit in days of peace, but the "Queen Elizabeth" was urgently needed to keep open the life-lines of Britain. With her sister ship, the "Queen Mary," whose radio equipment was installed by I.M.R.C. in 1936, she carried troops and supplies to the battle fronts.

Following America's entry into the war in December, 1941, the "express service" was started and the Cunard monsters, alone and protected only by their great speed, regularly ran the whole gamut of U-boat packs and surface raiders back and forth across the Atlantic, bringing American troops, American equipment, and American supplies to join forces in the struggle. In desperation, Hitler offered £50,000 and the highest honours of the Third Reich to any U-boat crew sinking one or both of these ships. But by their very impudence the giants outwitted the enemy and emerged unscathed. Between them, the "Queen Elizabeth" and the "Queen Mary" carried more than 1000000 troops to war.

In these ships, too, the wounded went home. In December, 1944, the following memorandum was passed to I.M.R.C.

Office of the Transport Chaplain,
"Queen Elizabeth,"
7th December, 1944

SUBJECT: Commendation of the Radio Department.

To: Captain Edward M. Fall (through the Staff Captain).

1. I would like to take this opportunity to commend to you the members of your Radio Department who have done such a marvelous job with the playing of recordings and providing special programs for the casualties aboard this voyage. The special sport broadcasts and the recordings provided have been enthusiastically received and helped so very much to ease the tension and pain of these our wounded veterans.

2. Every request and suggestion was complied with promptly and the extra effort necessary for a successful culmination of the idea furnished.

3. In behalf of these casualties I wish to thank these, your crew members.

(signed EMMETT G. JONES)
Chaplain (Major) U. S. Army,
Transport Chaplain.

These express ships served other purposes. The most outstanding figures of the war were carried to and from conferences, with resulting heavy use of the radio equipment. In May, 1943, a message of congratulation was received from Admiral of the Fleet Sir Dudley Pound, on completion of one of Mr. Churchill's visits to the United States in the "Queen Mary":

I do not previously remember such a large number of signals having come through in such a complete form as has occurred since we sailed. This greatly to the credit of the Signal and Cypher Staffs.

Again, in September, 1944, General Sir Hastings Ismay wrote:

I fear that you and your staff have been put to extra labours as a result of the Prime Minister and the British

Delegation being on board. I should like you to know that the manner in which all the extra-wireless traffic has been dealt with has been admired. Should you think well of it, would you let your staff know that their very efficient work has not passed unnoticed.

In addition to furnishing large quantities of all kinds of marine radio-communication and navigation equipment, the Company, in co-operation with the Mackay Radio and Telegraph Company in New York, organized 137 service depots in the principal ports of the world and made routine maintenance inspections with its own staff on 17,235 naval and merchant vessels. A total of 4,674 ships were supplied with I.M.R.C. equipment under contract with the Admiralty, Ministry of War Transport, and private shipowners.

Equipment for 24 coastal stations, including special radio beacons, was furnished to Admiralty, Trinity House, and other authorities.

Serving under I.M.R.C. during the war were 600-700 radio officers. 110 lost their lives. 37 were accorded honors and awards for distinguished service; eight were taken prisoners by the Germans, and two by the Japanese.

CREED AND COMPANY, LTD., CROYDON, ENGLAND

From its Croydon factory (Fig. 1), situated in the heart of the aerial bombardment danger area, Creed & Co., Ltd., carried out special work for the Services (notably the Royal Air Force), which called for tremendous and sustained effort, and resulted in the opening of two additional factories in South Wales. The first had to be extended within two years and the second was three times the size of the first factory. Despite these large expansions, the demand on the Company's manufacturing resources grew to such an extent that, by 1944, the co-operation of no fewer than 65 subcontractors had been enlisted.

Most of the special Creed instruments provided for the Royal Air Force are still on the secret list. There were, in addition, heavy demands for Creed Teleprinters and high-speed Morse apparatus for military communications embracing the defence telegraph network, which employed Teleprinters over a rapidly expanding cable network, linking up Navy, Army, and

Royal Air Force units with their headquarters in London and elsewhere.

The programme also provided for military telegraph communication in the field, using the Model 7 Teleprinter, made transportable and adapted for printing messages in triplicate; and for the main radio links connecting the London general headquarters of the British Navy, Army, and Royal Air Force with formation headquarters in Great Britain and in the different theatres of war, using the Creed high-speed Morse system of direct printing as the terminal apparatus.

For the U.S.S.R., a considerable quantity of Creed high-speed Morse equipment was made during the war. Also, for these and other Allies, there were produced complete telecommunication systems, including in addition to the Teleprinter, direct-current transmission equipment, teleprinter switching apparatus, power plants, and spares.

Among the special instruments provided for

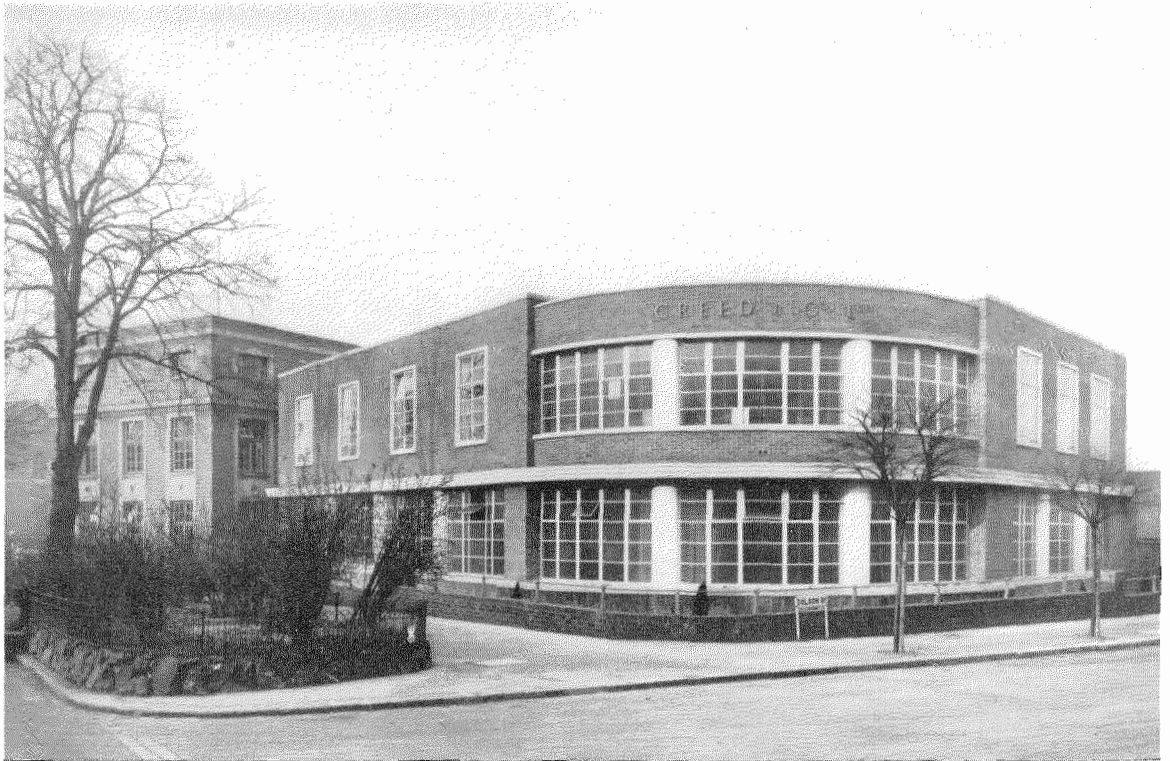

Fig. 1—Entrance to the main Creed plant at Croyden, England. Although situated in one of the most heavily bombed areas of the country, it escaped damage by enemy action.

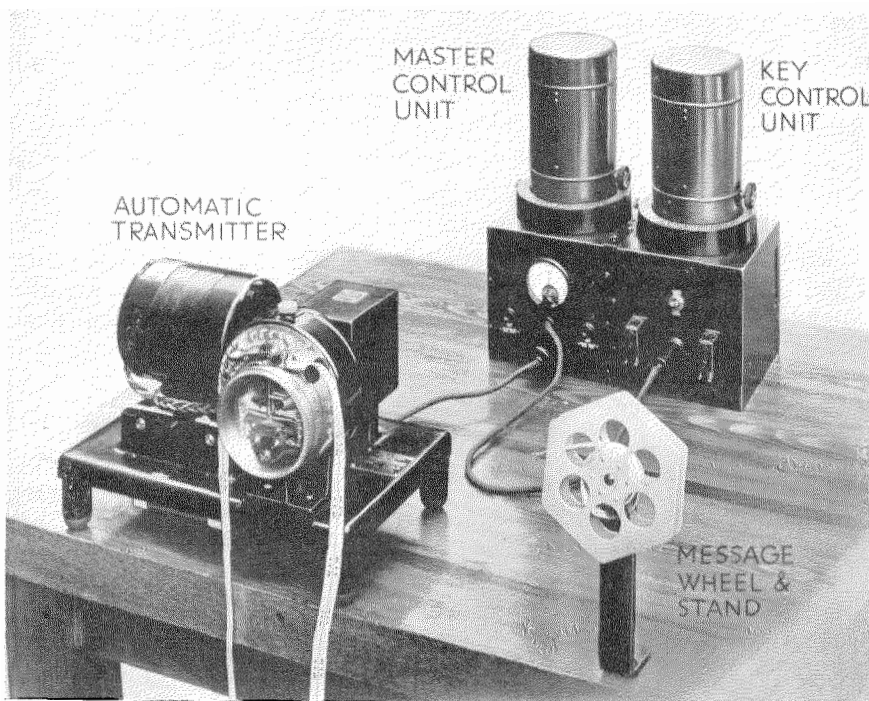

Fig. 2—Creed instructor's equipment for large-scale training of Royal Air Force personnel as Morse operators.

the Royal Air Force was Creed equipment for the intensive training, on a large scale, of personnel as Morse operators. With this training equipment, the Morse code was taught in a novel way and the equipment proved so efficient and popular that it was adopted also by the Army for training both male and female personnel.

The instructor's equipment, comprising an automatic tape transmitter, a master control relay, and up to 6 key control units, is shown in Fig. 2. Each of these units

controlled up to 10 solenoid-operated Morse keys, so that each instructor could be responsible for as many as 60 pupils.

Fig. 3 shows an operator's or pupil's position, comprising a solenoid-controlled Morse key, an inker unit and tape puller to provide a visual record of each operator's transmission, and headphones, used both for reproducing to each operator his own signals and for training in reception from the automatic tape transmitter.

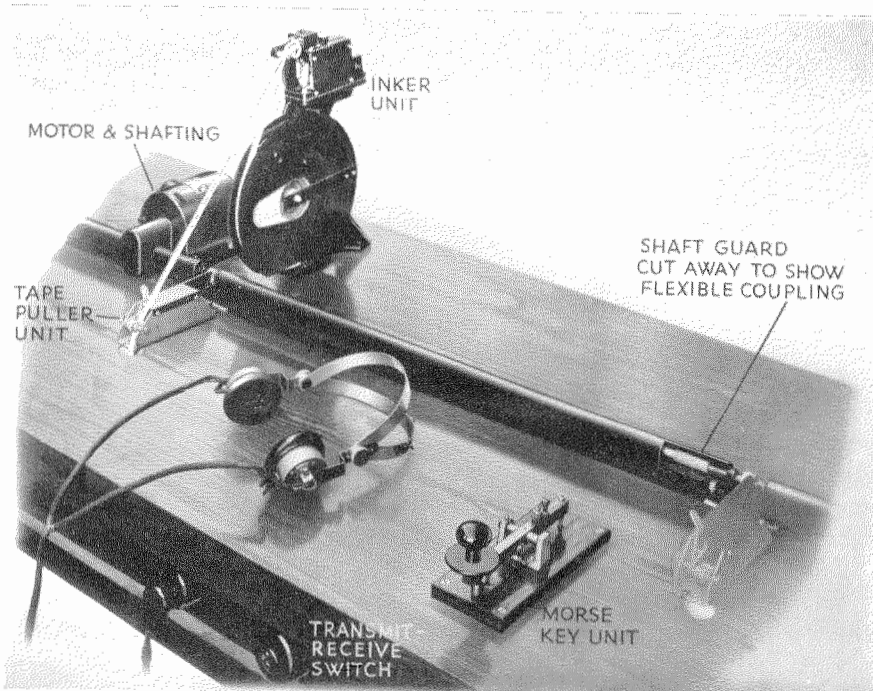

Fig. 3—One of the student's positions of Creed equipment for the intensive training of Morse operators for the Royal Air Force.

PORTO RICO TELEPHONE COMPANY, SAN JUAN, PUERTO RICO

At the start of hostilities the Porto Rico Telephone Company was faced with four main problems:

- A. Provision of local and toll facilities to the Armed Forces.
- B. Conversion of the manual exchange areas of San Juan and Santurce to automatic operation.
- C. Provision of facilities to governmental agencies and other organizations engaged in the war effort.
- D. Maintenance of adequate manual telephone service, particularly in San Juan and Santurce pending conversion of these areas to automatic, under extremely heavy demands imposed by the war effort.

Provision of Local and Toll Facilities to the Armed Forces

The entry of the United States into the war saw Puerto Rico being converted into a formidable military and naval establishment. A great naval base was under construction at Isla

Grande, located on the northeastern side of San Juan harbor. Military camps and other establishments of the Armed Forces were being erected in other parts of Puerto Rico; the largest was Borinquen Field, located on the northwestern tip of the island near Aguadilla. Other big camps sprang up at Losey Field near the city of Ponce on the southern part of the island, and across the bay from San Juan at Fort Buchanan. The quarters of the 65th Infantry, a regiment composed of Puerto Rican troops, at Cayey, also were considerably enlarged.

Numerous auxiliary landing fields were being constructed throughout the area and a wide military road was being built connecting San Juan with Borinquen Field. Simultaneously, a program covering the widening of streets and insular highways was pressed forward; a number of the old winding roads were being straightened.

The construction of bomb shelters, camouflaging of oil tanks, and other vital installations was pushed ahead. The Navy started construction on its biggest base in the whole Caribbean area, Roosevelt Roads. Military, naval, and civilian

personnel kept pouring into Puerto Rico as necessity demanded.

The Armed Forces at that time had no communication facilities of their own to meet increased demands involving both intelligence and communications, and turned to the Porto Rico Telephone Company to meet their requirements as they arose.

The requirements of the Armed Forces, as they affected the Telephone Company, related principally to leased toll lines and telegraph channels, and trunks from camps and bases to the nearest central offices. Other requirements involved numerous "dry circuits" in local areas, especially in the city of San Juan. Further, various observation posts established throughout Puerto Rico required essential telephone service.

On short notice, to meet the requirements which in many cases necessitated engineering and new construction, the Telephone Company worked under forced draft. Many circuits were released from the commercial network and turned over to the Armed Forces for their exclusive use.

As a result of long-distance circuit requirements, single channel type H-1 carrier systems were introduced into Puerto Rico for the first time. Thus, high-grade toll facilities were provided rapidly with minimum investment.

Composite sets were installed at San Juan and Aguadilla to provide teletypewriter channels between headquarters in San Juan and Borinquen Field. From Borinquen Field to Losey Field, and elsewhere, simplex circuits were made available for similar purposes. In all these cases the Telephone Company provided the channels and the Armed Forces the teletype equipment which was worked on the "neutral" system.

Small, previously relatively unimportant manual central offices suddenly became very important exchanges. A good example of this is the Aguadilla exchange, a small common-battery office with about 200 stations. This exchange became one of the main points of the communication system furnished to the Armed Forces. Previous to the war it had been practically unattended as far as plant maintenance was concerned; during the war years it was attended 24 hours a day, and both carrier and composite terminals were installed therein, as well as a modern local and toll test desk designed by the Telephone Company's engineers.

Comprehensive precautionary measures were taken to safeguard these high-priority facilities. They included emergency power plants, alternate routes both for talking circuits and teletype channels, coverage of strategic central offices 24 hours of the day with English-speaking personnel, intensive patrolling of toll routes, and a wartime schedule making available skilled plant personnel on short notice at any time of the day or night for repair purposes.

A task of this relative magnitude could not be undertaken without an acute realization of its urgency and importance. Engineering and construction work in many instances was done on rush orders to meet specific dates. In every instance the Armed Forces co-operated to the fullest possible extent in furnishing priorities for material urgently required on numerous jobs.

It is gratifying to record the receipt of a letter of commendation, dated October 8, 1945, from Colonel Edward A. Ryder, Department Signal Officer, Headquarters Antilles Department, for the Company's contribution to the war effort.

Conversion to Automatic of the Manual Exchange Areas of San Juan and Santurce

While the pressing activities of providing and maintaining facilities for the Armed Forces were being pushed ahead with all possible speed, the Telephone Company also was proceeding with a major project involving the conversion to automatic of the manual exchange areas of San Juan and Santurce. Since the successful conclusion of this project has been recorded in this journal,⁴ it need only be mentioned here that this conversion entailed the construction of over 276000 duct feet of conduit and the installation of cable containing over 229000000 conductor-feet of wire, the erection of a building especially designed to house the automatic equipment, the installation of 8000/10000 lines/terminals of 7-A2 rotary equipment (manufactured by the Federal Telephone and Radio Corporation, Newark, New Jersey), and the installation of dial telephones throughout the area. The cutover took place on June 3, 1945.

⁴ José D. Dominguez, "Conversion of San Juan, Puerto Rico, Telephone Plant to Automatic Operation," *Electrical Communication*, v. 23, pp. 35-40; March, 1946.

Provision of Facilities to Governmental Agencies and Other Organizations Engaged in the War Effort

With the advent of war, the demand for telephone service by governmental agencies, civilian defense, and other organizations engaged in the war effort, increased greatly while the procurement of additional central-office equipment and other essential material became more and more difficult. Strict adherence to orders issued by the War Production Board regulating installations, procurement of material, etc., made it possible for the Telephone Company to meet essential demands for service from all of these sources.

Maintenance of Adequate Manual Telephone Service

Maintenance of adequate manual telephone service under the extremely heavy demands imposed by the war effort was particularly difficult in San Juan and Santurce. Completion of the San Juan-Santurce conversion to automatic made the problem less difficult. Likewise, the problem of procuring and training bilingual telephone operators, necessitated by the great influx of English-speaking personnel, was eased by the San Juan-Santurce conversion.

In the city of Arecibo, the exchange building was reconstructed and remodeled and all central office equipment replaced. The original building had two floors with the central office on the second floor; the remodeled building is an attractive one-story structure.

To conserve scarce material, 100-percent-trunking local *A* positions were installed in the largest offices of San Juan and Santurce. At a critical period when the load on existing equipment necessitated additional operators, use was made of "split *A*" positions, thus permitting

two operators to handle a single position. After new positions were added this splitting was eliminated.

During the period 1940-1945, the number of local positions in the San Juan manual exchange was increased by 61 percent and toll switch-board equipment was increased 100 percent. In the Santurce manual exchange the number of local positions was increased 82 percent. Simultaneously, the *B* trunking positions in these two exchanges were increased 125 percent.

General Comments

Some appreciation of the task confronting the Telephone Company in meeting the greatly expanded demands imposed by war will be gained when it is considered that the Porto Rico Telephone Company is a relatively small organization. It serves over 20 thousand subscribers.

These achievements of the Telephone Company, furthermore, afford an interesting example of local management and I.T.&T. System co-operation. Thus, the conversion of San Juan and Santurce to automatic operation could hardly have been achieved during the war years without assistance from various I.T.&T. companies, as indicated by the following quotation from the previously cited article in *Electrical Communication*:

This being the first installation of automatic equipment in Puerto Rico, considerable thought had to be given to the question of manpower; personnel from various I.T.&T. companies had to be brought in to help in the installation and to instruct the local personnel in both the installation and maintenance of the equipment. At the height of the installation work, there were 146 persons working in three shifts; of these 118 were Puerto Rican, 18 were employees of I.T.&T. affiliated manufacturing companies, and 10 were loaned by other telephone operating companies of the I.T.&T. system in Mexico, Peru, the Argentine, and Brazil.

CUBAN TELEPHONE COMPANY, HAVANA, CUBA

From 1939 on, the Cuban Telephone Company co-operated with the U.S.A. defense and war effort, initially in connection with extensive modifications and improvements of the Guantanamo Naval Base. This co-operation was later extended to the bases and air fields at San Antonio de Los Baños, San Julian, La Fé, and Camaguay, which were utilized at the start by the Army and Navy for antisubmarine defense and later, mainly Guantanamo and San Antonio de Los Baños (known as the Batista Air Field), for training purposes.

In line with requirements of the Armed Forces, extensive telephone and teletypewriter systems were furnished. They covered the entire island, as may be seen in Fig. 4, and connected the various bases with a link to Miami, Florida, via the cables of the Cuban American Telephone and Telegraph Company.

Re-engineering and reconditioning of existing equipment was done locally with excellent results. Teletypewriter circuits, at their peak, reached close to 3000 kilometers and were made possible primarily through the release of carrier systems from the Telephone Company's plant. In partial replacement, the Signal Corps, Puerto Rico, loaned the Telephone Company type H-1 carrier systems.

Because of the congested toll network of the Cuban Telephone Company, special operating methods were devised for giving priority service to all departments of the U. S. Government functioning in Cuba. Preferential service likewise was rendered to war industrial projects, the principal ones including the Cuban Mining Company at Cristo, Oriente, and the Nicaro Nickel Company at Lengua de Pájaro, Oriente.

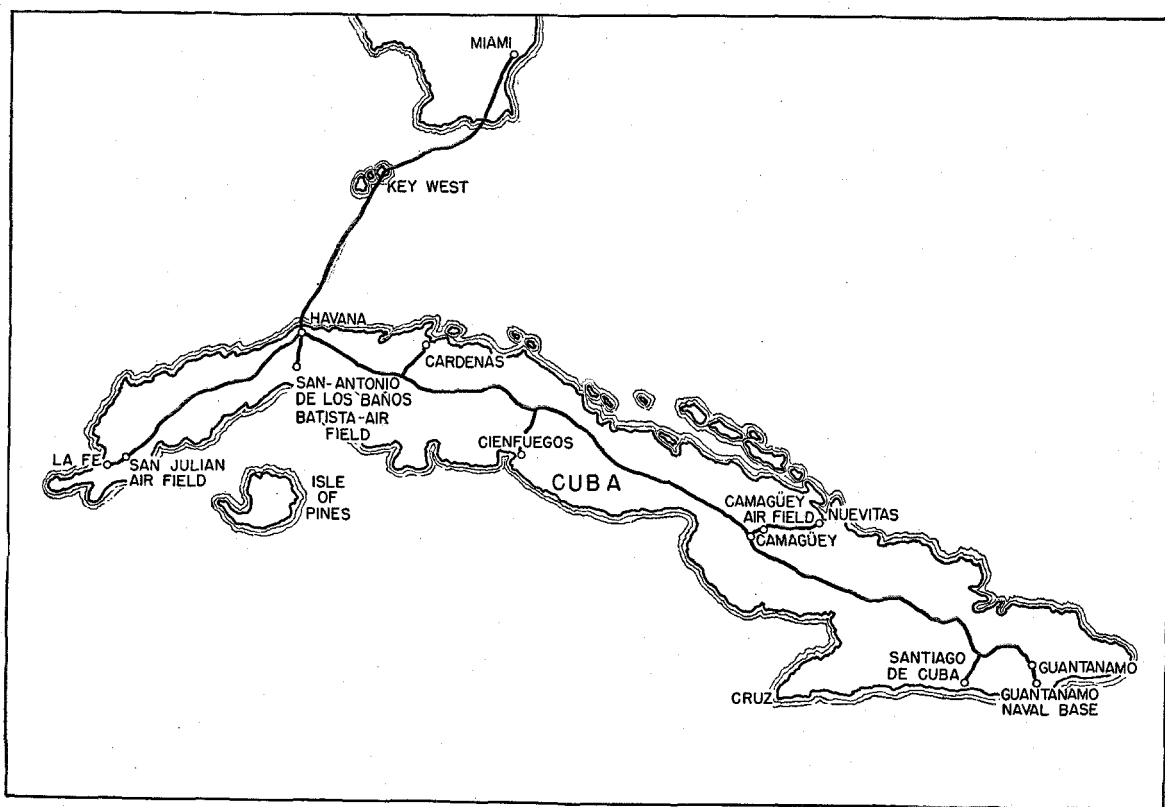

Fig. 4—Map of Cuba and tip of Florida showing cities connected to the telephone and teletypewriter system of the U. S. Armed Forces.

Work undertaken by the Telephone Company at the Guantanamo Naval Base was in charge of Mr. M. I. Merlin. The U. S. Navy Department awarded him the Meritorious Civilian Service emblem (Fig. 5). The letter of notification, dated 13 September, 1943, read:

1. Upon recommendation of the Board of Awards of the Bureau of Yards and Docks, the Chief of the Bureau has this date awarded you the Meritorious Civilian Service emblem as recognition of the excellent services rendered over and beyond those normally required in connection with your duties in the construction program of this Bureau.

2. The Chief of Bureau congratulates you upon your outstanding performance and loyalty, and expresses his appreciation of the example you have set for your fellow workers in furthering the prosecution of the war in the vital construction front.

(signed B. MOREEL),
Rear Admiral (CEC),
U. S. Navy.

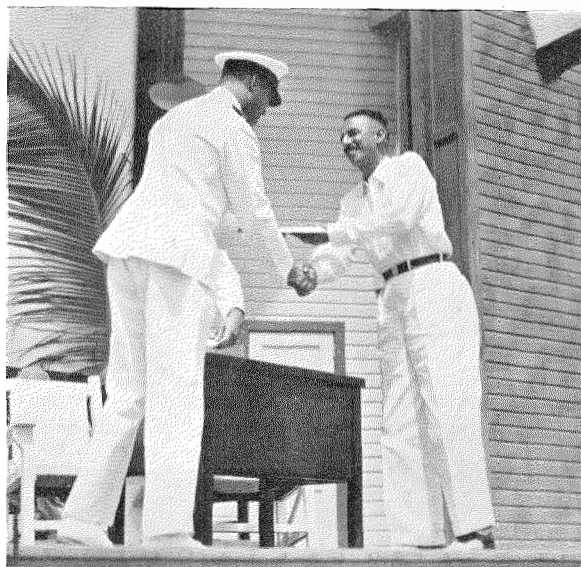

Fig. 5—M. I. Merlin, resident engineer of the Cuban Telephone Company, receiving from Lieutenant Commander G. S. Robinson the Meritorious Civilian Service Award for his activities in charge of the telephone work at the Guantanamo Naval Base.

LABORATOIRE CENTRAL DE TÉLÉCOMMUNICATIONS, PARIS, FRANCE

The advance of the German army into France in the early years of the war obviously presented the difficult problems of impeding and countering the German war effort. Aside from its inherent interest, the following account of the resulting disposition of facilities and the activities of Laboratoire Central de Télécommunications, formerly Les Laboratoires LMT, is presented as a tribute to the heroism and resourcefulness of its personnel.

At the time of the German-French Armistice (June, 1940), the Paris laboratories had orders for various telecommunication equipment, part of which was for military use. With the occupation of northern France, the problem of how to carry on required urgent solution. Extreme alternatives were:

A. Continuation of work in Paris. While advantageous from the viewpoint of available facilities, such as tools and specially equipped buildings, the disadvantages were great since activities would have been completely under German control.

B. Abandonment of the Paris buildings and installation of the laboratories in the unoccupied region. This procedure would have placed at

enemy disposal facilities especially designed for research and development purposes.

A compromise plan was adopted. Activities were maintained in Paris, but confidential work for the French Government was transferred to Lyons to avoid German control.

Agreements made by the Vichy Government necessitated the acceptance of German orders. It was, however, found possible to confine orders to equipment developed by the Company, excluding everything that would have to be built in accordance with German plans. The following major advantages resulted:

- A. Long-delayed execution of orders.
- B. Provision for ultimate equipment applications different from those visualized by the Germans.
- C. Continuation of studies relating to normal activities.

Manufacture for the French Authorities nevertheless necessitated authorization by the German Authorities, who demanded complete information on proposed equipments, their use, etc. To prevent drawing German attention to actual

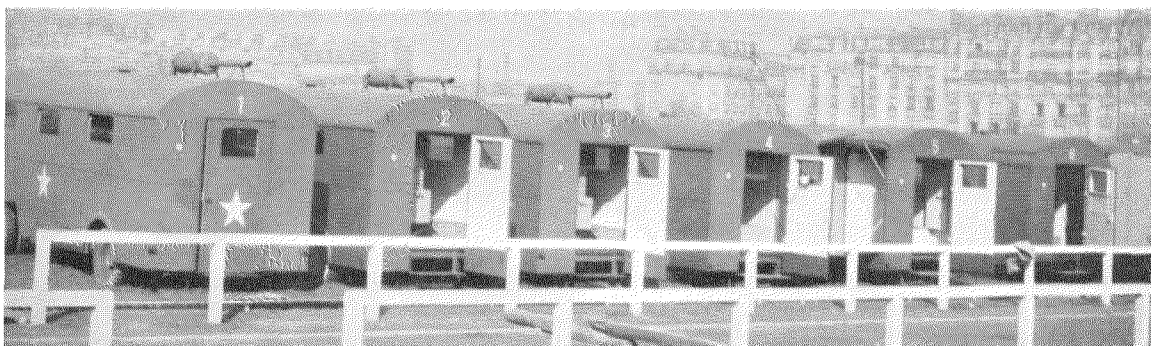

Fig. 6—Six of the 17 trailers in which “Sig Circus,” the 60-kilowatt mobile radio station, is housed may be seen above. Facilities are included for 200 000 words daily of radiotelegraph traffic, complete broadcast transmission including a studio and control booth, as well as facsimile transmission and reception, and wire, film, and disk recording.

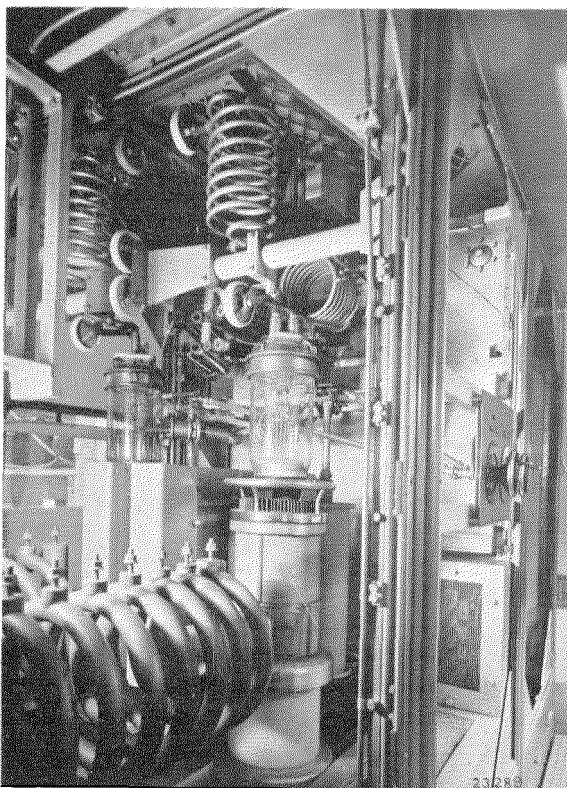

Fig. 7—Power stage of the 60-kilowatt “Sig Circus” transmitter.

intent, such information was of course presented in appropriate form. Finally, however, only one order of this kind was received; a broadcasting station for the French Authorities. The Germans probably planned eventually to use it for their own purposes.

Important research studies on the production and utilization of 3000-megacycle (10-centimeter) waves continued during the occupation,

both in Paris and in nonoccupied France notwithstanding German or Italian control. In 1941, in fact, the application of these waves was considered for a future link between Nice and Corsica and it became necessary to make transmission tests to study their propagation characteristics over the ocean.

A transmitter was manufactured secretly in Paris and installed at Fort Coudon, 800 meters from Toulon. Radiation was from a horn pointed out the window as shown in Fig. 9. When a signal was given that a Control Commission was on its way, equipment was partly dismantled and hidden in rooms where army beds were stored. Signals were transmitted over an intricate warning system devised with the cooperation of the guard of the fort.

The receiving station had to be installed on a vessel sailing 100 to 200 kilometers from land. Since no ship was allowed to leave port without permission, use was made of the *Ampère*, an authorized cable-repair ship, shown in Figs. 10 and 11. Thanks to the trips of the *Ampère* in the direction of the Spanish and Algerian Coasts, important information was obtained on the propagation of ultra-high-frequency waves.

Subsequently other experiments were made between Sète and Port Vendres. At Sète, laboratory personnel was lodged in the same hotel as the Italian Armistice Commission and experiments were made during mealtimes.

Notwithstanding German control, it was also possible to develop in Paris equipment for a 12-channel telephone system, using 9- to 10-centimeter waves. This system has since been placed in operation by the French Posts, Telegraphs and

Telephones Administration and is to be the first link of this type in service.

Laboratories at Lyons were started in 1940 at the request of French Authorities. Their purpose was to proceed in the "free" region of France with studies started during the war. Activity was concentrated in an effort to supply the Army and the Navy with up-to-date equipment. Such equipment was supplied for naval vessels and the colonies.

The Lyons laboratories soon came into contact with the leaders of the underground movement centered at Lyons. Various equipment was supplied and assistance rendered in organizing secret information systems. These Laboratories' underground activities, spread over four different buildings, were continued under the severe German control during the last two years of the war but were not discovered.

One of the orders placed by the Germans was particularly important; it covered the manu-

facture of 8 high-frequency radio transmitters of 60-kilowatt capacity to be mounted on trucks. Delivery of the first model was requested by June, 1942, and the rest at the rate of one per month.

Under pretext of various difficulties, promise of delivery of the first model was postponed until 1944. Actually the equipment was never delivered. Moreover, it was possible to obtain from the Germans interesting data on their most modern equipment, even including complete manufacturing information.

The laboratory studies were conducted towards producing 60-kilowatt transmitters of the most modern type, for single-sideband operation and using tubes with forced ventilation. Hence, a few months after the liberation of Paris, the laboratories delivered to the Signal-Corps of the American Army a most up-to-date 60-kilowatt mobile transmitter.

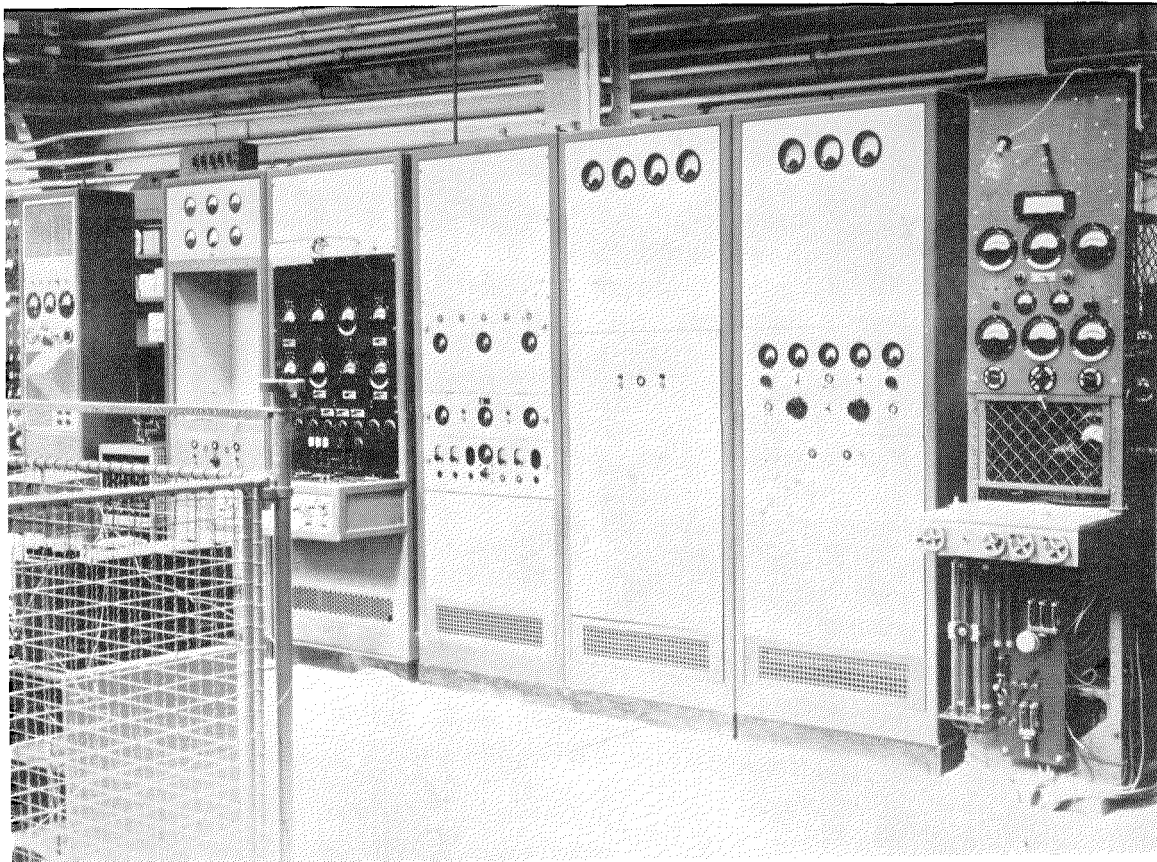

Fig. 8—15-kilowatt broadcast transmitter, camouflaged between vacuum-tube testing panels, in the Paris laboratories



Fig. 9—3000-megacycle horn radiator used in propagation tests. The apparatus was hidden in a dismantled fort near Toulon. Colonel Labat, Chief of the Research Section of the French Signal Corps, who is standing at the window, was executed by the Germans for his underground activities.

This contribution was the answer to a problem peculiar to the Armed Forces of the U.S.A. In addition to the need for intercommunication facilities within the European Theater of Operations, the expeditionary forces of the United States were faced with the problem of keeping in constant contact with a far-distant home front, despite rapid advances to unpredictable locations. The logical solution to this problem was a complete, high-power radio station which could be easily moved wherever it was needed. The Signal Corps assigned the task to the laboratories of the I.T.&T. subsidiary in Paris. It involved the planning of the complete system, using a certain amount of existing equipment, but requiring also the construction or procurement of high-power radio amplifiers and power plants.

Construction was completed in the record time of less than three months. The station was unique in that it was built in 17 large trailers

and developed an output power of 60 kilowatts. It has a capacity of 200 000 words daily, plus complete broadcast facilities including a broadcast studio and control booth, as well as equipment for facsimile transmission and reception, and for wire, film, and disk recording. The station, partly shown in Figs. 6 and 7, can be set up in approximately 24 hours and is known as the "Sig Circus." It is now carrying press traffic from the Nuremberg trials in Germany. For the rapid production of this outstanding contribution, the Laboratories were awarded the "A" flag by the U. S. Army.

Coincident with the delay policy followed in

the case of the 60-kilowatt transmitter requested by the Germans, sizable quantities of raw material and piece parts were stored for post-war use. Consequently, it was possible to construct in a very short time 4 similar transmitters for the French Administration.

Further, on the pretext of authorized orders on hand, parts for about 100 transmitters of different ratings were produced and stored in Paris and Lyons. Transfer of material between occupied and unoccupied France was found possible by declaring it to be required for electric-current distribution applications.

With material thus accumulated, the following equipment was produced:

A. From August, 1944, in buildings occupied by the Germans, the installation of two telegraph transmitters was started. The parts were introduced as "telegraph material" without giving details. The Germans working on the floor below failed to investigate the matter closely inasmuch as the necessary authorization for installing this

“telegraph material” had been obtained from established authorities. These transmitters were placed in operation during the Paris insurrection and contacted London, Algiers, Dakar, Bamako, etc.

B. A truck-mounted transmitter was placed at the disposal of General de Gaulle.

C. Two 20-kilowatt telegraph transmitters were assembled from parts transported to Toulouse, where the transmitters are still in operation.

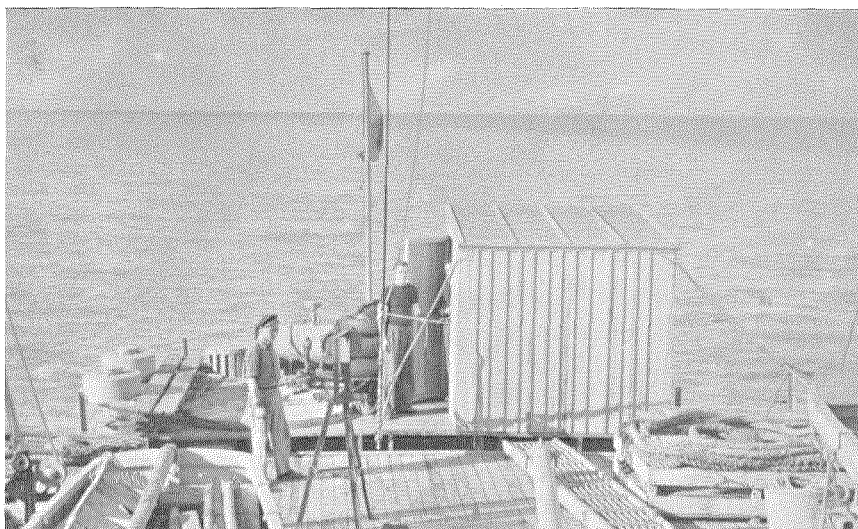

Fig. 11—Presumably at sea to repair a cable, the *Ampère* carried the 3000-megacycle receiving equipment for making propagation tests. The apparatus is installed in the wooden hut which is surrounded by miscellaneous objects to give it an air of innocence.

D. High-frequency 1-kilowatt transmitters were assembled and installed in the buildings of the Laboratories. As many as 14 ultimately were placed in operation for military and civil use.

E. With circuits previously used for testing vacuum tubes, a 15-kilowatt broadcasting transmitter was installed in the Laboratories, as shown in Fig. 8, and was placed in operation during the Paris insurrection prior to withdrawal of German forces. It was connected by Administration employees to the underground studio by means of cable straps in various telephone exchanges. Inasmuch as the Germans had destroyed transmitters in the Paris area, this transmitter served the French Broadcasting Service for contacting the British Broadcasting Corporation in London and announcing on August 24th the arrival of General Leclerc's troops at the Paris Town Hall. It was also utilized during the insurrection for conveying orders to various fighting groups, to request help at critical points, and to plan the distribution of ammunition. Further, it was the first broadcasting station from which General de Gaulle spoke from Paris after the liberation, and it was used by the American authorities in connection with programs of the American Forces Network (A.F.N.).

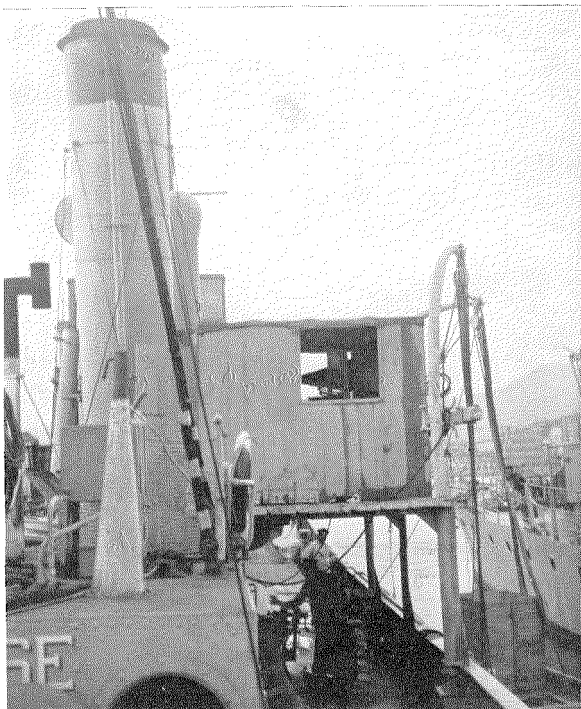

Fig. 10—Installation of 3000-megacycle equipment on board the *Ampère* near Toulon. The packing case being hoisted is hidden from sight by another ship at the right.

STANDARD ELECTRICA S/A, RIO DE JANEIRO, BRAZIL

Although greatly handicapped by raw-material and apparatus shortages, Standard Electrica, Rio de Janeiro, produced considerable quantities of equipment contributing to the war effort. These included central-battery switchboards for the Brazilian Coastal Artillery School, portable military field sets and switchboards, time-interval systems for coast-artillery field control, selenium rectifiers for aeronautical repair shops, power control panels for Brazilian cruisers, and reels and reel supports for field telephone wire for the Brazilian Armed Forces.

Radio transmitters operating at various frequencies and with capacities ranging from 300 watts to 10 kilowatts were furnished to the

Brazilian and U.S.A. Armed Forces and for civilian applications pertaining to the prosecution of the war. Rhombic antennas were constructed for the Brazilian and U.S.A. Armed Forces. One receiving and one transmitting rhombic antenna, specially designed for the Brazilian Army, was erected in Rio de Janeiro for communication with the Brazilian Expeditionary Forces in Italy and directed towards Naples.

Standard Electrica also was active in maintaining ship telephone and radio installations in working condition, performing emergency repairs, and providing engineering assistance whenever required.

COMPANHIA RADIO INTERNACIONAL DO BRASIL, RIO DE JANEIRO, BRAZIL

A perspective of Companhia Radio Internacional do Brasil's contribution to the war effort can best be gleaned by noting the facilities and services offered to the public prior to the attack on Pearl Harbor, in December, 1941, compared to those available at final victory in August, 1945. In appraising this achievement it should be stressed that practically all items of materials and equipment required for the installation of these services were included in the strategic materials list. Actually, much of the equipment was assembled locally with the best materials then available. The personnel problem also was difficult inasmuch as most trained radio technicians were either serving in the Brazilian army or occupied on other vital communication work.

At the time of the attack on Pearl Harbor the Company's facilities and services were limited to the large transmitting and receiving stations in Rio de Janeiro which maintained radiotelephone and radiotelegraph circuits with New York and Buenos Aires. The outbreak of war made it necessary to enlarge the sphere of activities, especially within Brazil. These expanded services included the following circuits to Rio de Janeiro where they could be switched to the other towns indicated and to all exterior points insofar as radiotelephone service was concerned. Radiotelegraph service was limited to traffic destined for the exterior only.

DATES SERVICE OPENED TO PUBLIC

	Radiotelephone	Radiotelegraph
Recife.....	March, 1943	May, 1943
Fortaleza.....	April, 1943	April, 1944
Porto Alegre.....	June, 1943	June, 1943
Natal.....	June, 1943	June, 1943
Baía.....	July, 1943	July, 1943
Curitiba.....	July, 1943	July, 1943
Belem.....	September, 1943	September, 1943
Victória.....	May, 1943	

The stations most frequently used (in order of importance) by the U. S. Army, Navy, and Air Forces were: Recife, Natal, Baía, Belem, Fortaleza, Porto Alegre, Curitiba.

Inasmuch as the U. S. Armed Forces had their own teletype and telegraph system, the main Company facility used was the interior radiotelephone system. Due to security measures it was naturally not possible to employ the radiotelephone for certain types of communication involving confidential or restricted subjects; nevertheless, it played an important role in the transaction of business essential to the prosecution of the war.

Supplementary services offered during the war period included:

A. Retransmission of high-frequency broadcast programs from the U.S.A. and Great Britain for use of local broadcasters.

B. Operation to Recife and Rio de Janeiro of signal-strength recording equipment on a 24-hour basis. The results of these tests were used

in determining modifications in high-frequency broadcasting practices to assure full coverage of programs directed to Brazil.

C. Free services to members of the U. S. Armed Forces stationed in Brazil to their families in the States as a measure of boosting morale.

Among the U. S. agencies whose activities were aided materially by the radiotelephone circuits made available during the critical war period were the following:

A. Rubber Development Corporation, which used the Rio-Belem and Fortaleza circuit extensively.

B. U. S. Purchasing Commission, which used the Rio-Baia circuits in connection with the purchase and shipment of quartz crystals.

Inauguration ahead of schedule of the Natal service was particularly urgent in connection with preparations for the African invasion. Navy planes were used to transport 1430 kilograms of equipment from Rio de Janeiro to Natal in September, 1942, and temporary radio service was established in a room in the Naval Observer's section as the Company had not then been able to rent the space required.

COMPANHIA TELEPHONICA RIO GRANDENSE, RIO GRANDE DO SUL, BRAZIL

The effects of the outbreak of war in Europe in September, 1939, were soon felt by the Companhia Telephonica Rio Grandense. Shortages became acute after the entrance of the U.S.A. into the struggle and were intensified by Brazil's participation in August, 1942. Nevertheless during the war period the Company was able to construct the Rosairo-Livramento toll line, bringing the latter city on the Uruguayan border into the company's toll network. Further, in 1943, it was possible to rebuild the Itaquí, São Borja, and Quarai long-distance lines and thus incorporate these three cities on the Argentine border into the toll network. In 1944, despite shortages and extreme difficulty in transport, the Alegrete-Uruguaiana lead was completed

whereby Uruguaiana, situated on the Argentine border, also was included in the general toll network.

The extension of the toll network to include cities on the Uruguayan and Argentine borders aided substantially in the war effort. Moreover, the Company's long-distance network served to promote public safety.

While incidental to the war effort, it is interesting to note that in May, 1941, there occurred what since has been called the worst flood recorded in Brazil. The loss of life was small, but material damage was extremely heavy and such that all utility services except the telephone were interrupted.

COMPANHIA TELEFONICA PARANAENSE S. A., CURITIBA, BRAZIL

Like all public-service entities in Brazil and elsewhere, Companhia Telefônica Paranaense was handicapped by war restrictions on essential materials and equipment in carrying on normal operations, quite apart from any planned development program for meeting growing service demands.

Inasmuch as Curitiba was the headquarters for the 5th Brazilian Military Region, the telephone network became of prime importance to the military authorities. One of the first jobs undertaken by the Company was the reconsolidation of a toll line extending along the coast from Paranaguá to Guaratuba, a distance of 50 kilometers, where numerous military coast patrol

stations were provided with telephone service because of submarine activities in regional coastal waters. An actual attack on a merchant ship was witnessed by the Company's line gang during the overhauling of this toll line.

Because of the relatively large population of Europeans of Axis origin in Curitiba and other parts of Paraná, the Company, on request, cooperated closely with military and police authorities. It likewise participated in blackout rehearsals common to the war period and made arrangements to render strategic telephone service in case of power failures or other service interruptions.

The linking of the Company's network to the

radiotelephone network of its associate, Companhia Radio Internacional do Brasil, in July, 1943, served further to broaden the scope of cooperation with the military authorities who were given efficient radiotelephone service to the Federal capital and other national military regions.

Early in April, 1944, work was commenced on a new airport for Curitiba, situated 17 kilometers from town. The construction of the airport was undertaken by American Army engineers together with an American staff of technicians assisted by Brazilian personnel. Telephone facilities were provided linking the

construction project with the Curitiba main exchange and toll network.

A year later, the airport was officially turned over to Brazilian authorities and is considered among the best airports in South America. Its runways provide landing facilities for every type of aircraft, including C-54 transport planes and B-29 Superfortresses.

Civilian plane service was scheduled for inauguration at the new airport before the end of 1945. Companhia Telefônica Paranaense is providing telephone facilities for the leading airlines utilizing this new airport.

AKTIEBOLAGET STANDARD RADIOFABRIK, STOCKHOLM, SWEDEN

Aktiebolaget Standard Radiofabrik started manufacturing in Sweden early in 1939, the program being confined to three main product lines: commercial radio, selenium rectifiers, and vacuum tubes. Plans called for procuring drawings and manufacturing information from I.T.&T. associate companies, and the sale of its own as well as I.T.&T. System products. With the advent of war and the consequent breaking of contacts with associate companies, it became necessary for Standard Radiofabrik to undertake its own design and development work to safeguard production and to aid in meeting the national needs.

The first design task undertaken was the development of marine radio equipment. A radiotelephone unit for fishing vessels, shown in Fig. 12, was made available in 1939 and proved so successful that several series were made for the Radio Bureau of the Swedish Telephone Administration and other authorities. Design work on marine radio equipment was continued in close co-operation with the Radio Bureau.

In 1940, a 300-watt low- and high-frequency ship's radio transmitter was developed for use in the Atlantic traffic; also two telephone transmitters and a telephone receiving set. These were later supplemented by a universal ship's receiver and a 150-watt telegraph and telephone transmitter for small freighters. Repeat orders, representing practically all types required in the Swedish mercantile marine service, earned a high reputation for the Company.

Contracts were secured in 1939 for a number of 2-kilowatt coastal radio stations followed by two types of 4-kilowatt capacity arranged for remote control on 9 preset frequencies. These equip-

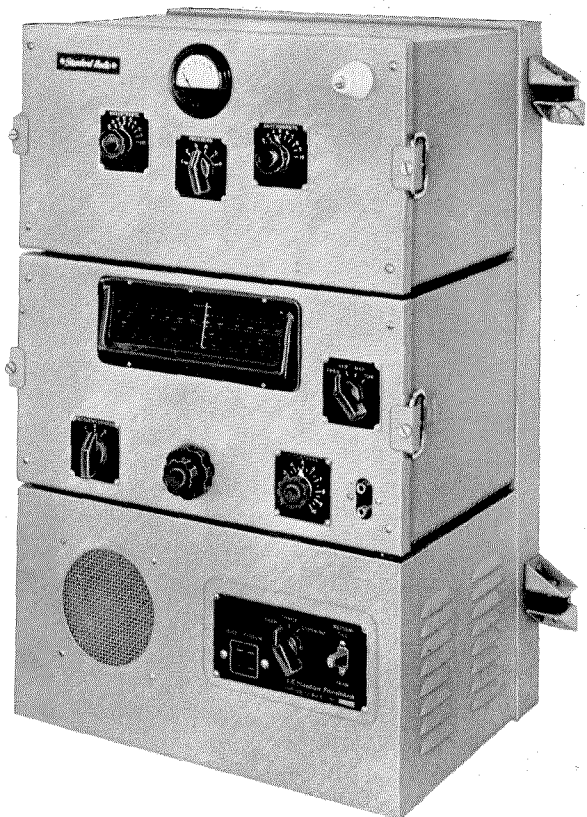

Fig. 12—Radiotelephone installation for fishing vessels designed by AB Standard Radiofabrik.

ments, illustrated in Fig. 13, served not only as coastal radio stations but also as ground stations on air fields and, with certain modifications, as high-frequency transmitters for point-to-point use.

Before the war, very-high-frequency police radio equipment was introduced in Sweden by Standard where it was first installed in Stockholm. It proved highly successful and was subsequently adopted in other cities. While the first installations used amplitude modulation, recent installations have employed frequency-modulated equipment arranged for remote control on three preset frequencies. These also have found application in other fields, such as in the wire railway communication network.

From the beginning of hostilities in the autumn of 1939, the Swedish military authorities relied on the Company to aid in the production of signaling equipment called for in the armament program. As already indicated, no provision had been made for development work within the Company and the first military equipment, therefore, was manufactured to Government specifications. One notable exception, however, occurred in 1940 when two specimens of a portable military receiving and transmitting set (Type PM-7), designed by the Bell Telephone Manufacturing Company, Antwerp, were rescued from Belgium just before the German invasion and were brought to Stockholm. Based on data obtained from these models, an intensive manufacturing program was started and four months later regular deliveries were made to the Army in quantities sufficient to satisfy the demand for an efficient portable field radio transmitter and receiver.

An important product line of Standard Radiofabrik has been the production of aircraft radio equipment which has found application primarily in civil air transport. AB Aerotransport (ABA), the only company in Sweden operating air transport during the war, soon found it impossible to import the necessary radio equipment for meeting an ever-increasing demand for service. Aerotransport, therefore, in 1942, contracted with Standard for the development of equipment urgently required. This development work, carried out in 1942-1944, resulted in an aircraft station (Type AS 100) consisting of a low- and high-frequency transmitter, communi-

cation receiver, direction finder, and instrument landing receiver, all compactly mounted on a common rack. ABA's planes are now being provided with this equipment to which other units are being added as and when required. This

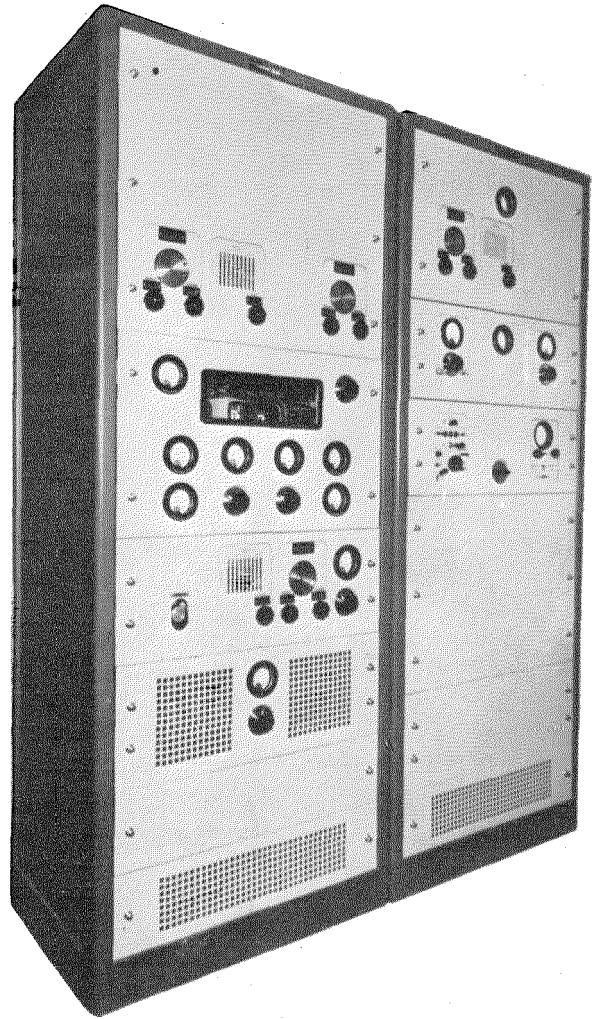

Fig. 13—4-kilowatt high-frequency transmitters used for coastal, aeronautical ground, and point-to-point stations in Sweden.

type of equipment also has been acquired by the Danish Transport Company.

During the war the status in Sweden of broadcast transmitters was static partly because of economic considerations and partly due to difficulties in obtaining water-cooled tubes. To gain experience with frequency-modulated waves, the Telegraph Administration in 1942 placed an order on Standard for a 1-kilowatt frequency-modulated broadcast transmitter, which was

developed and manufactured in the Company's factory.

The need for more powerful medium-frequency broadcast transmitters has now become so pressing that the Administration has ordered two 120-kilowatt medium-frequency transmitters. These are of Standard Telephones and Cables, Ltd. (London), type CM 7, and will be constructed by that company. They will replace two Standard 10-kilowatt broadcast transmitters now in service in Gotëborg and Sundsvall.

Compared with other types of rectifiers, the selenium rectifier gained a predominant position and Swedish equipment of this type long before the war attained a high level of performance. Standard, by adopting several ingenious design features and by standardization of types, elements, and assembly methods, has maintained its front-rank position as a supplier of this type of equipment.

Prior to 1939 no radio tubes were produced in Sweden and the decision of the Company to start tube manufacture was welcomed by the

Government, particularly in view of the prospects of isolation resulting from a war in Europe. After successfully launching a program for the production of telephone repeater tubes, other types were requested by various Government departments. This demand gave rise to many and difficult problems, not the least of which was the lack of important raw material for which reliable substitutes had to be found. Another difficulty was that a variety of tube types were required but usually in relatively small quantities.

Gas-filled tubes were made almost from the start, notably thyratrons, voltage-regulating tubes, and ballast lamps. The importance of this contribution to the country in meeting the need for substitute tubes in existing apparatus cannot be measured by the relatively small quantities involved.

Standard, incidentally, is the only concern in Sweden manufacturing cathode-ray tubes, both of the electrostatic and electromagnetic types. Its line also includes both gas-filled and high-vacuum phototubes.

I.T.&T. ASSOCIATE COMPANIES IN NEUTRAL COUNTRIES

I.T.&T. companies in neutral countries, either directly or indirectly in many cases, contributed substantially towards the Allied cause. The wartime activities of Aktiebolaget Standard Radiofabrik, Stockholm, Sweden, have been indicated; Standard Electrica, Lisbon, serves as another example. This company, primarily a sales organization, operated a small shop mainly devoted to repair work. Despite its meagre facilities, it participated in the United Nations war effort by undertaking a sizable number of repair jobs involving radio, degaussing, and electrical equipment on ships that put into Lisbon after being damaged by enemy attacks

and mines. For this work the United Kingdom Shipping representative, Lisbon, under date of 8th May, 1945, wrote the Company as follows:

At the successful termination of this long and difficult war, I wish to thank you on behalf of the Ministry of War Transport and myself, for the great assistance your firm has always given and to inform you of the deep appreciation that has been felt by us.

I hope that as soon as the world settles down to a more normal state that you will enjoy all prosperity.

I should like you to convey to all your staff our deep appreciation of their work.

A. W. Benson,
Captain R. N.

UNITED RIVER PLATE TELEPHONE COMPANY, LIMITED,
BUENOS AIRES, ARGENTINA

Argentina, prior to ending of relations with the Axis in January, 1944, and declaring war in March, 1945, had been supplying vitally needed products in great quantities to the Allies. Her busy ports, maintaining a nonbelligerent status towards United Nations' vessels, served as the mouth of the cornucopia through which flowed the meat, grain, minerals, and many other sinews of war originating in the back country. In carrying on and developing this trade, on which the fighting forces and workers of the Allied nations were so dependent, the telephone played an indispensable role.

War repercussions resulted in an ever-increasing shortage of telephone materials and equipment, as well as huge demands for telephone service—demands that in Argentina, as in other countries, could not be met inasmuch as war-imposed requirements deflected materials and the world's peacetime communication manufacturing facilities into the production of armaments, ships, airplanes, trucks, and a multitude of essential items. Although vast quantities of all kinds of radio and communication equipment were produced, the insatiable requirements of the armed forces left little for civilian consumption.

Prior to the war Argentina imported telephone equipment from Europe. England ceased exportations when war demands absorbed the full output of her industries; and the fall of Antwerp closed the last possible Continental source of products that United River Plate Telephone Company (Unión Telefónica) needed from abroad. Despite shortages, many items were obtained from the

U.S.A.—limited in volume but nevertheless considerable. Moreover, procurement of complicated mechanisms such as those comprised in automatic switching equipment, requiring highly specialized and costly production facilities geared to fairly steady peacetime demands, or lead-covered cable containing prime military materials, presented a hopeless prospect in the first years of the war.

Had Unión Telefónica passively accepted the situation as one of the inevitable calamities of war, it would have been impossible to record, as is the case today, that the people of Argentina still enjoy a thoroughly efficient and modern telephone service. To the group of able, versatile, and resourceful specialists, responsible for rendering telephone service to a nation, remote from the world's large industrial centers, the seemingly insuperable problems of wartime operation served as a challenge. At vast pains and considerable extra expense, and with the active participation of the manufacturing engineers and plant specialists of Compañia Standard Electric Argentina, the lack of essential importations,

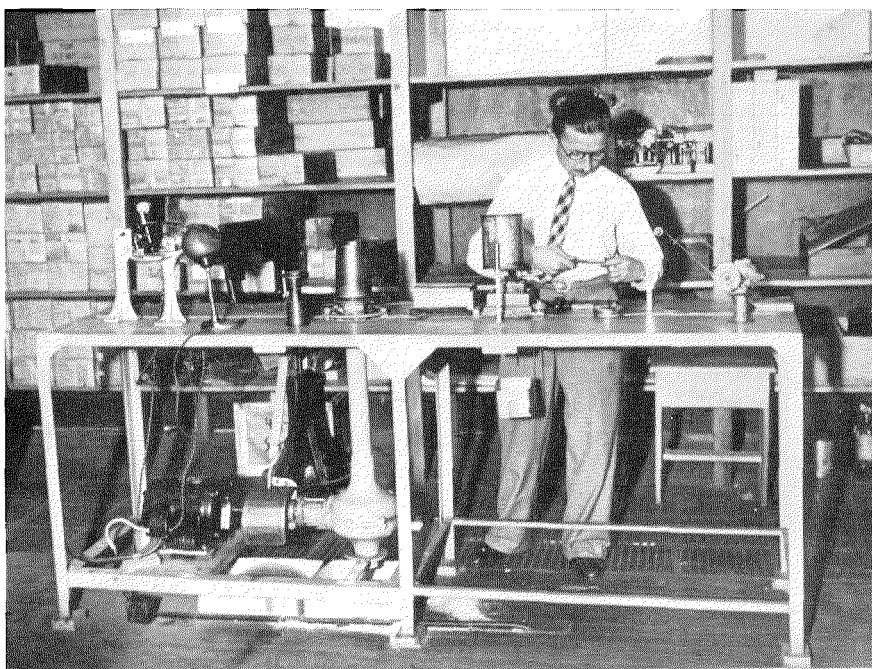

Fig. 14—Machine improvised by Compañia Standard Electric Argentina for drawing wire. The familiar rear-end structure of an automobile serves a new purpose in this machine.

which otherwise might have resulted in complete breakdown of the telephone service, was overcome to a substantial degree.

The possibilities of local production led to an investigation of the practicability of creating manufacturing plant capacity in Buenos Aires for turning out piece parts otherwise unobtainable and, eventually, even entirely new and assembled equipment. Such studies, even when the time factor is paramount, are not overnight jobs. If the findings be favorable, a long interval normally will elapse between the initiation of projects and the delivery of the orders. That interval had to be bridged.

Accordingly it was decided to start at once on a provisional basis to meet piecemeal such miscellaneous requirements as a most realistic interpretation of the emergency and a canvass of existing possibilities might suggest.

Hastily organized and temporarily housed in a former telephone central office, as well as in several converted dwellings and an abandoned cinema studio, a manufacturing plant was started; it was undersized, overcrowded, and inadequately equipped with machinery and tools, but in the emergency it produced many urgently required items and piece parts constituting important elements in the telephone system. The job had to be done with what few machines could be found in Buenos Aires suitable or adaptable to the purposes and with whatever machines and tools could be constructed locally from raw materials retrieved from second-hand stores, junk yards, or elsewhere. It could be accomplished only by men able to visualize in the rear axle of an old automobile a usable element for building a machine to draw copper wire, shown in Fig. 14, in old sewing ma-

chines, essential parts of winding machines for relay production; and in a pile of scrap that had originally come from Shanghai, the necessary elements for constructing a braiding machine to remake switchboard cords. The Plant Department of Unión Telefónica, furthermore, expanded its work shops, salvaging everything that could be reconditioned, assembling and reassembling equipment, innovating where possible, and substituting available materials for scarce or unobtainable ones. Fig. 15 illustrates a switchboard cord winder constructed of scrap material.

During the war years, the 12500 skilled men and women of Unión Telefónica served approximately half a million Argentines as well as the public was being served anywhere and far better than in many countries despite most exceptional difficulties of a technical nature resulting from the disruptions of a war-torn world. Thus, from the commencement of the war to the end of 1945, it was possible to install 350882 telephones, of which 131066 represented a net gain, and to handle calls at an average daily rate of 6 million local and more than 45 thousand long-distance communications.

The fact must be faced, nevertheless, that Argentina has thousands of backed-up applica-

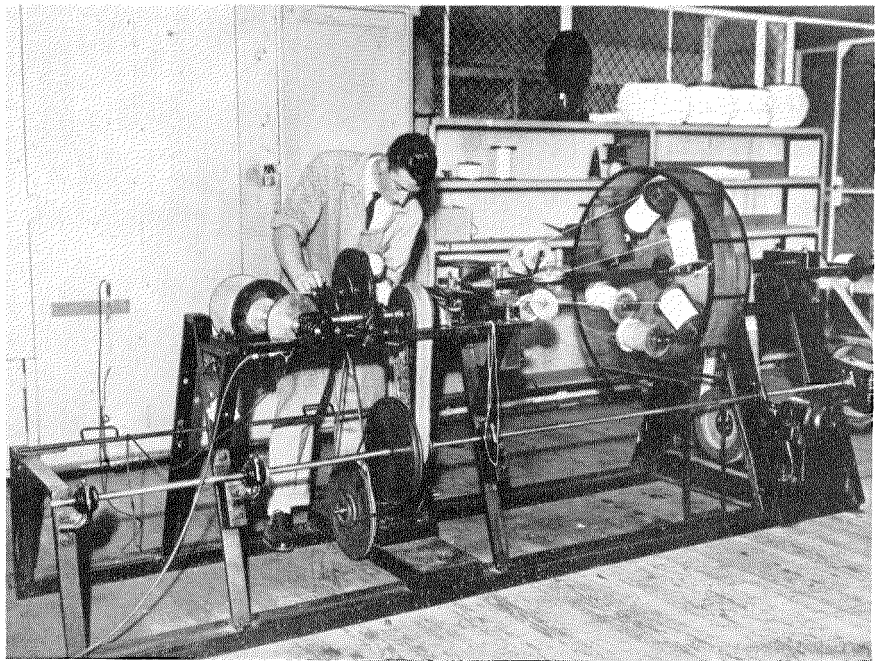

Fig. 15—Switchboard cord winder made by Unión Telefónica from scrap materials.

tions for service that must await large-scale additions to central-office automatic equipment and outside cable plant. Development plans for serving new territories likewise must wait. Plans for providing additional facilities, however, have been formulated and will be consummated as rapidly as materials and manufacturing capacity become available. Moreover, plans for postwar rehabilitation and plant expansion to meet all existing and future demands in the most orderly and economical manner also have been formulated and will be implemented at the earliest practicable date.

Argentina does not yet have a complete factory unit for meeting all the requirements of the telephone industry but is well on its way. Compañia Standard Electric Argentina's new factory is operating with increased efficiency and further

expansion is planned. Thus, it can be said that war-imposed scarcities brought some compensation inasmuch as it hastened the birth of a telephone equipment manufacturing industry that in the postwar years will grow in size and importance commensurate with the requirements of the national economy.

In the war effort of Unión Telefónica and Standard Electrica S.A., the old tradition—"the message must go through"—is exemplified. It is once again a story of co-operation portraying skill, initiative, perseverance, and high devotion to duty, so characteristic of the telephone industry—qualities that have been conspicuous in making the telephone the most universally applicable and accessible of all the means of modern communication.

RETROSPECT AND PROSPECT

War activities dramatically revealed the great mutual benefits derivable from collaboration among many nations. Similarly, the practicability of effective peacetime collaboration has been demonstrated by the I.T.&T. group of companies and their predecessors—their experience involves numerous countries and extends over six decades. A wartime example, an outgrowth of peacetime practices, was the rapid up-building of Federal Telecommunication Laboratories, Inc., and Federal Telephone and Radio Corporation. This accomplishment was made possible through key executives and engineers made available from Standard Telephones & Cables, Ltd. (London), Bell Telephone Manufacturing Company (Antwerp), and Le Matériel Téléphonique (Paris). (In the latter case it was found possible to transfer personnel and technical information to New York even after the occupation of France by the Germans.) Thus, Federal was enabled to contribute substantially to the U.S.A.'s war effort and directly or indirectly to aid all the Allied Nations.

Some I.T.&T. System wartime achievements are listed below. In certain cases developments antedated the war years but are included because of important war and postwar applications or extensions. It is felt that all can be justly regarded as truly pioneering in the sense that they determined future trends or "fashions," not only in the U.S.A. but in other countries.

Radio Communications and Navigation

MARINE RADIO UNIT

In 1941 I.T.&T. System engineers initiated, developed, and produced a single unit for the radio room in Liberty type vessels, containing all the radio equipment required by law. Subsequently, a comprehensive high-frequency marine radio unit was developed. At the National Maritime Exposition, held in May, 1946, in New York City, Mackay Radio and Telegraph Company displayed a new "console" containing all equipment required by law for passenger and cargo ships. Occupying one-third less space and with 15 fewer controls, it performs functions that would require 5 separate pieces of apparatus in even the most modern versions of marine radio equipment. In addition, it eliminates 10 storage batteries required in earlier all-in-one models.

VACUUM TUBES

Among the many types developed by Federal Telephone and Radio Laboratories and produced by Federal Telephone and Radio Corporation is a thoriated-tungsten filament tube capable of delivering 600 watts at 35 percent efficiency at 600 megacycles—the most powerful triode now available at this frequency. Another triode with thoriated-tungsten filament produced 1000 kilowatts of peak power at 200 megacycles with 2 tubes as oscillators. An oxide-coated indirectly heated cathode tube was developed

for pulse applications at 600 megacycles; a single tube delivered 560 kilowatts peak, 360 watts average, power at 600 megacycles for 12 hours.

INTERNATIONAL BROADCASTING

In 1945, Federal constructed for the Office of War Information two 200-kilowatt high-frequency broadcast transmitters for installation on the West Coast. They are more powerful than any previously existing in the U.S.A. Equipment manufactured by Federal, in addition to the 100-kilowatt high-frequency tubes, consisted of the main transmitter units, rectifier power supplies, 150-kilowatt modulators, water cooling systems, radio control panels, and other auxiliary components.

Ever-increasing recognition of the importance of international broadcasting in the cause of world peace was emphasized recently by the trend towards establishment of a United Nations Telecommunication Section and the interest expressed by a number of officials in global broadcasting facilities. The latter recalls an article by Federal, "Beyond Our Shores the World Shall Know Us" (reprinted in this journal), outlining a proposal involving 12 stations individually powered at 200 kilowatts and grouped in an East Coast area and in a West Coast area for effectively meeting the requirements of worldwide coverage. The basic idea of a plan for such a broadcasting system was originally presented to U.S. Government authorities in September, 1941, by the Federal Telephone and Radio Corporation.⁵

That the United Nations requires international broadcasting facilities seems obvious. It may reasonably be asked whether the U.S.A. also should not have global broadcasting facilities commensurate with its position and responsibilities in world affairs.

MICROWAVES

The early 1930's brought the advent of commercial microwave working as a result of the installation across the Strait of Dover of a high-quality duplex microwave telephone system,⁶

⁵ "A Proposal for A Global Shortwave Broadcasting System," *Electrical Communication*, v. 33, n. 2, pp. 154-166; 1944.

⁶ First demonstrated publicly in 1931. See articles in *Electrical Communication*: v. 10, n. 1, 1931; v. 12, n. 1, 1933; v. 12, n. 3, 1934; v. 14, n. 4, 1936; v. 15, n. 3, 1937; v. 16, n. 1, 1937; v. 16, n. 2, 1937; v. 22, n. 4, 1945.

developed and installed in 1933 by I.T.&T. associate companies in England and France. This system, operating on 18 centimeters with sharply concentrated beams, embodied principles that found important applications in radar and other war developments; it antedated other commercial microwave systems by about a decade and is the forerunner of modern microwave relay systems.

Research work on pulse-time modulation was commenced by I.T.&T. associate companies in London and Paris before the outbreak of war in Europe and subsequent developments in this system of modulation were applied to equipment furnished to the Armed Forces. The system has significant potentialities in the fields of point-to-point communication, sound broadcasting, and color-television broadcasting.

Applications of pulse-time modulation to point-to-point communication and multiplex sound broadcasting have been described.^{7,8} In addition to other advantages, it has been demonstrated that pulse-time modulation is capable of transmitting 24 simultaneous conversations on a common carrier frequency over a microwave relay system.⁹ Similarly, in sound broadcasting 12 programs can be transmitted simultaneously from the same station on a single carrier frequency. Pulse-time modulation is adaptable also to the transmission of color television with sound on the same microwave channel.

Another development of microwave utilization in communications has been carried out in the laboratories of the I.T.&T. associate companies in Paris. It consists of a 12-channel frequency-modulated 3000-megacycle radio equipment, which may be included as a segment of a high-grade telephone cable routing, without any effect on the quality of the long-distance circuits. This system has been put in operation on one of the regular telephone service routes in the Paris area.¹⁰

⁷ E. M. Deloraine and E. Labin, "Pulse Time Modulation," *Electrical Communication*, v. 22, n. 2, pp. 91-98; 1944.

⁸ D. D. Grieg, "Multiplex Broadcasting," *Electrical Communication*, v. 23, pp. 19-26; March, 1946.

⁹ D. D. Grieg and A. M. Levine, "Pulse-Time-Modulated Multiplex Radio Relay System-Terminal Equipment," *Electrical Communication*, v. 23, pp. 159-178; July, 1946.

¹⁰ A. G. Clavier and V. Altovsky, "Simultaneous Use of Centimeter Waves and Frequency Modulation," *Electrical Communication*, v. 22, n. 4, pp. 326-338; 1945.

DIRECTION FINDERS

The commercial production of direction finders was initiated by Federal in 1921 with the Kolster radio compass. Manually rotatable unshielded loop collectors and six-tube receivers were used. In 1926, the shielded loop was introduced as was the quadrantal-error compensator which consisted of a continuous flexible metal band operating as a cam to correct the pointer indication.

The first radical change was made in these direction finders in 1932 with the 101, 102, 105, and 106 types¹¹ which were produced in large quantities up to and during the war and were standard equipment on many Liberty ships, Victory ships, and Coast Guard vessels.

During these same years the RC5 automatic compass¹² for aircraft was produced in large quantities in France. An automatic direction finder also was installed on a Spanish naval vessel in 1931. Other installations were made on destroyers for the Portuguese Navy, as well as in many European commercial and some military aircraft. In 1934, Le Matériel Téléphonique, Paris, made the first installation in an airplane of an automatic direction finder giving 360-degree indication. In 1937, I.T.&T. introduced in the U.S.A. the first automatic radio compass for aircraft and numerous demonstration flights were made with this equipment aboard experimental ships of American Airlines and United Airlines.¹³

Automatic direction finders indicate on a 360-degree scale the direction of arrival of a radio wave. The operator need only tune to the transmission frequency and read the bearing from the indicator. The simplicity and rapidity of taking measurements have made automatic equipment of especial importance in aeronautical navigation. The addition, in 1939, of the cathode-ray tube as an indicator contributed greatly to the split-second operation of long-range direction

finders which were so effective during the war in detecting and locating enemy submarines.

These instantaneous direction finders included a series of equipments designed for shipboard and for aircraft use and the well-known SCR-291 high-frequency direction finder, credited with the saving of hundreds of airplanes on the Atlantic at a certain period of the war when no other long-range navigation system was available.

INSTRUMENT LANDING SYSTEMS

Because of pioneering efforts and previous production of instrument landing equipment for airports serving the principal cities of the U. S. A., Federal was well prepared to develop and furnish this type of equipment required for military purposes during the war; it, in fact, was the only producer of this essential equipment for the Army Air Forces. The SCS-51 instrument landing system has been installed and used by the Air Technical Service Command and the Air Forces in Europe, North Africa, the Pacific, and elsewhere.

In planning the future development of instrument landing systems, the Provisional International Civil Aviation Organization, the Commonwealth and Empire Radio Conference on Civil Aviation, and the Army Technical Service Command Electronic Subdivision Advisory Group on Air Navigation have specified the SCS-51 as the basic system to which further attention will be directed.

HIGH-FREQUENCY TRANSMISSION LINES

Federal was the first company to produce a solid-dielectric high-frequency transmission line meeting all the stringent requirements of the Armed Services; it made the first and only commercially successful dual coaxial transmission line used for direction finding and instrument landing systems; it developed, in conjunction with the Radiation Laboratory, the first spiral delay line; and pioneered in the development of low-capacitance transmission lines.

Telephony

SELENIUM RECTIFIERS

Introduced by I.T.&T. into the U. S. A. in 1938, rectifier plates totalling well over 30000000

¹¹ E. H. Price and W. J. Gillule, "Marine Navigation Aids—The Radio Direction Finder and the Gyro-Compass," *Electrical Communication*, v. 22, n. 1, pp. 56-69; 1944.

¹² H. Busignies, "The Automatic Radio Compass and Its Applications to Aerial Navigation," *Electrical Communication*, v. 15, pp. 157-172; October, 1936.

¹³ H. Busignies, "Mountain Effects and the Use of Radio Compasses and Radio Beacons for Piloting Aircraft," *Electrical Communication*, v. 19, n. 3, pp. 44-70; 1941.

were supplied by Federal from 1940 to the end of the war in 1945. Plate sizes varied from 1 millimeter with a microscopic dot of selenium to a plate of 118-millimeter dimensions. Rectifier stacks varied from lightweight units for use in aircraft and proximity fuses to large units for electroplating applications requiring high current and low voltage.

SIMPLIFIED TELEPHONE SETS

In 1942 I.T.&T. companies materialized a telephone set of revolutionary¹⁴ design with components co-ordinated to facilitate installation and achieve maximum reliability and economy in maintenance.

The interconnecting medium is a molded plastic block into which is incorporated the bare copper bus wiring, the gravity switch complete with plunger, and all connecting terminals for the line, hand set and dial cords, and several circuit elements. All elements connect directly to this block without the aid of supplementary wiring. When the set was first described, it was stated that its significant improvements would influence the future general trend of design; it has, in fact, already found imitators.

¹⁴ E. S. McLarn, "Simplified Subscribers' Telephone Sets," *Electrical Communication*, v. 21, n. 1, pp. 3-12; 1942.

UNIVERSAL SYSTEM

Before the war I.T.&T. began the development of a new automatic switching system—the Universal System. This new development is again well underway and arrangements have been made to manufacture initial equipment for a 10000-line central office to be inaugurated in Havana, Cuba, in 1947.

This summary of accomplishments is made possible largely through I.T.&T.'s unique position in the communication field. In 1925, I.T.&T. purchased International Western Electric Company,¹⁵ thus placing at its disposal plants and highly developed organizations in many countries. Another perhaps even more potent factor is the differing conditions encountered in I.T.&T.'s farflung operations favoring a balanced viewpoint and a broad approach to new problems. Obviously, no one country can possess a monopoly of ideas, and constructive criticism promotes alertness in realigning organizations and implementing decisions promptly and effectively. Hence, I.T.&T. companies, with their long background of experience and technique in numerous countries in practically all phases of electrical communication, not infrequently have been first in materializing developments significant in the advancement of the communication art.

¹⁵ Now International Standard Electric Corporation.

Recent Telecommunication Developments

ADJUSTING TOOLS FOR CERAMIC CROSS-TALK-BALANCING CAPACITORS—The use of ceramic capacitors for far-end cross-talk balancing required the development of special tools to overcome the electrical and mechanical difficulties of adjustment.

The ceramic capacitors have a movable rotor to which is attached a hexagonal nut with a slot. Balancing units, consisting of two capacitors mounted on an insulant platform, are inserted in pigeon holes in a balancing frame. The cross-sectional dimensions of a pigeon hole are $1\frac{9}{16}$ by $1\frac{9}{16}$ inches. The capacitor rotors are in a plane parallel to the sides and the clearance between the rotor nut and the sides is approximately $\frac{3}{16}$ inch.

A tool or combination of tools is required to give 360-degree rotation of the capacitor rotor, the movement of the tool handle being limited to 65 degrees. This requirement coupled with convenience of use in the small space available was the main problem.

A relatively large torque is required to turn the capacitor rotors, especially to overcome initial sticking. For robustness and strength it was necessary to make the tools of silver steel. For accurate balancing the capacitive effect of the tool must be less than $0.5 \mu\mu f$ and therefore the metallic area must be kept small. This latter condition makes the use of an ordinary hexagonal metal spanner undesirable.

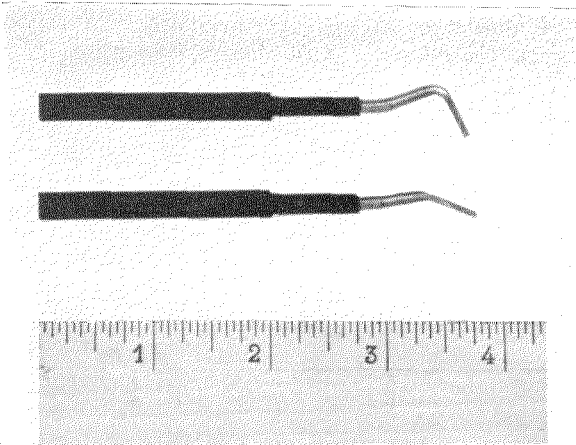

Several types of special tools were developed; however, simple tommy bars engaging in the slot in the rotor nut and with insulant handles proved to be most satisfactory.

Two tommy bars were necessary to obtain the full 360-degree rotation. The portion of the tools that engages in the slot is of rectangular cross-section. The first set of tools, developed by trial, consisted of one tool with the shaft bent at the end to an angle of 70 degrees and one straight tool.

Calculation based on manufacturing variations of the balancing unit and frame showed that the maximum value of the angle through which the tool handle can be operated may be as low as 65 degrees. Further consideration gives $57.5 < \phi < 90$ and $\phi - 65 < \psi < 32.5$ as the possible combinations of two tools having angles ϕ and ψ , respectively.

The angle ϕ of the large-angle tool was taken as 65 ± 5 degrees. This is consistent with the above limits and less bending is required during manufacture than if a larger angle were chosen. Field trials showed that approximately 90 percent of the condensers could be adjusted by a tool with an angle of about 25 degrees, the large-angle tool only being required for the remaining 10 percent. The angle ψ of the small-angle tool was taken as 25 ± 3 degrees. This is consistent with the limits above.

This final set of two tommy bars of angles 65 degrees and 25 degrees was found in field trials to be much more convenient and robust than the other types considered.

Standard Telephones and Cables Ltd., London, designed these tools.

• • •

RECONDITIONING OF PARIS-CALAIS 12-CHANNEL CARRIER CABLE—Some interesting work was carried out by Standard Telephones and Cables Ltd., London, under contract with the British Post Office during the winter of 1944–1945 in reconditioning part of the Paris-Calais 12-channel carrier cable following the liberation of northern France.

The cable was manufactured and laid in 1939 and 1940 by Lignes Télégraphiques et Téléphoniques and was intended to link up with the Anglo-French (1939) multipair submarine cable as part of the London-Paris 12-channel carrier scheme. It has a total length of 283 kilometers, divided into 9 carrier repeater sections averaging about 31 kilometers in length, and is a composite cable incorporating both directions of carrier transmission, as well as varying numbers of 2- and 4-wire audio-frequency loaded circuits and some screened radio pairs. Sixteen 12-channel carrier systems may be operated over the cable, one direction of transmission being provided by a group of eight 1.3-millimeter star quads in the centre of the cable, and the reverse direction by sixteen 1.3-millimeter pairs surrounding the star quads and separated therefrom by a concentric screen of copper and steel tapes. The cable is armoured and laid directly in the ground over the greater part of its length.

With the German occupation of France in 1940, the scheme originally envisaged was, of course, interrupted, but between Paris and Amiens "poling" of the carrier circuits was completed by Lignes Télégraphiques et Téléphoniques and far-end balancing equipment installed. Between Amiens and Calais, however, neither "poling," nor cross-talk balancing were carried out, but instead the carrier circuits in two repeater sections were loaded for audio-frequency operation. After the liberation of northern France in 1944, a scheme was put in hand for reconditioning the carrier circuits (including deloading where necessary) and completing the "poling" and cross-talk balancing. In addition, the cable was to be linked to England by new coaxial submarine cables with balanced-pair land

extensions from Calais to the coast, the immediate objective being the provision of 12-channel carrier facilities between London, Calais, Amiens, and Paris. To expedite completion of the scheme the work was shared, Standard Telephones and Cables being responsible for three repeater sections, and Lignes Télégraphiques et Téléphoniques for two sections between Amiens and Calais, as well as for any reconditioning between Paris and Amiens.

The main operation of interest in the reconditioning work was that of improving to a satisfactory value the near-end cross talk between the oppositely directed groups of circuits. This involved (a) the location and repair of missing or damaged portions of the concentric screen, and (b) "poling" of the carrier circuits.

The procedure adopted for locating discontinuities of the screen was analogous to the well-known method for locating an impedance irregularity on a circuit by analysis of an impedance—frequency curve measured from one end of the circuit. The near-end cross talk between a pair of oppositely directed circuits having high coupling at some point was measured in magnitude and phase at a number of frequencies from the appropriate repeater station, and curves were plotted for the components of the cross talk versus frequency. Analysis of these curves, based on a knowledge of the propagation constant of the circuits, then enabled the location of the source of high coupling to be estimated. In a typical case in which this method proved useful, it was subsequently found that the Germans had repaired the cable for audio-frequency working after bomb damage, but had only bridged the gaps in the screen with pieces of wire. This discontinuity of the screen was approximately 4.8 kilometers from the nearest repeater station, the resultant degradation of the worst value of near-end cross talk between oppositely directed circuits at that station amounting to 8 decibels at a frequency of 60 kilocycles per second.

The "poling" of the carrier circuits for near-end cross talk between oppositely directed groups is a feature not normally encountered on 12-channel carrier cables, as separate cables are employed for the two directions of transmission. With the Paris-Calais type of cable, however, a certain amount of "poling" is necessary to ob-

tain values of near-end cross talk substantially better than the specified values. Details of the "poling" technique cannot be given here, but it may be stated that it involves opening a number of cable joints within the first few kilometers of a repeater station and cross-splicing the carrier circuits to obtain the most satisfactory reduction of cross talk.

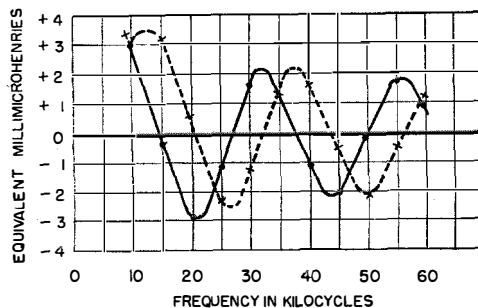

Variation with frequency of components of near-end cross talk between oppositely directed circuits for a discontinuity of screen 4.8 kilometers from the repeater station. The near-end mutual impedance was measured on pairs 12 to 31 from Tilques on the Lillers-Tilques section of the Paris-Calais carrier cable. The reactive component is the solid line and the resistive component is dashed.

• • •

SEVERN TUNNEL CABLE—As part of the open-wire telephone and telegraph system of the Great Western Railway, a new cable was laid through the Severn Tunnel in 1944. This cable comprises 12 star quads of 40-pound conductor and is the first in Great Britain to be loaded for open-wire carrier working. It was supplied and installed by Standard Telephones and Cables Ltd., London.

The route length involved is 4,870 yards, the cable being terminated on the Cornish side at the entry to the tunnel at Pilning, and on the Monmouth side at the top of a ventilating shaft at Sudbrook. (The tunnel proper on the Monmouth side emerges at a point some distance from Sudbrook.) Through the tunnel, the cable, which is armoured with a single layer of 0.080-inch galvanized iron wires, is supported on the tunnel wall by galvanized iron bearers fitted at 4-foot intervals. Special cleats were provided for supporting the vertical run in the Sudbrook ventilating shaft.

Owing to the density of traffic through the tunnel, it was not possible to proceed with cable installation without interference with normal

train schedules. Arrangements were therefore made for traffic to be suspended on three consecutive Sundays. The cable lengths were loaded into a special train and laid from the trucks on the first day. A similar train for the loading coils was provided on the second day, when the coil cases were installed. Jointing and testing, which proceeded as far as possible during the first two days, were completed on the third. In all of the above installation work, assistance was provided by men from the Great Western Railway Engineering and Signals Department.

Because in addition to the normal voice-frequency circuits, provision had to be made for the extension of a 3-channel open-wire carrier system and for similar future carrier systems, the side circuits of two of the quads in the cable were loaded with 4.8-millihenry coils on a nominal 1000-foot spacing. (The side-circuits of two other quads were loaded with 28-millihenry coils on a nominal 2000-yard spacing for voice-frequency operation.)

On the carrier circuits, the actual loading sections include 14 of 973 ± 3 feet each and one of 977 feet, and the cable was installed in lengths corresponding to those sections. At each end, a terminating unit is provided incorporating a fractional carrier loading coil and a terminating network so designed that with the additional shunt capacitance of the pole wiring etc., it matches the open-wire impedance over the whole frequency range.

On the pairs loaded for voice frequency there are two full loading sections of 1,947 yards and a half section of 976 yards. There are thus two 28-millihenry loading points within the tunnel and one 14-millihenry half coil in the terminating unit at the Pilning end. The 14 loading cases within the tunnel, including two containing both carrier coils and voice-frequency coils, are of the stubless type, and were specially designed for mounting on the tunnel wall, the maximum projection from the wall being $6\frac{1}{2}$ inches. To guard against corrosion from sulphurous fumes, the cases have an outer protective covering of phenol fibre, the space between the welded steel case and the outer fibre case being hot-compound filled.

As loading of the carrier pairs increases their impedance from 140 to 620 ohms, the contribution to far-end cross talk resulting from capaci-

tive unbalance is of increased importance and tight limits were therefore set on those unbalances both in factory lengths and in jointing during installation.

• • •

HIGH-FREQUENCY TERMINATING UNIT FOR OPEN-WIRE LINES—A new terminating unit was recently developed by Standard Telephones and Cables Ltd., London, to meet a demand for a simple variable-resistance termination for testing open-wire telephone lines at frequencies up to 150 kilocycles per second. Such a unit is required for cross-talk and impedance measurements on open-wire lines over which 12-channel or 3-channel carrier systems are to be operated.

The range of impedances covered by the unit is 500 to 670 ohms, the termination value being adjustable in steps of 10 ohms. This caters for all pin spacings and conductor gauges likely to be encountered on open-wire carrier lines, and enables any nominal impedance in the range to be simulated to within 5 ohms, i.e. within 1 percent. This corresponds to a reflection coefficient of 0.5 percent, which is ample for normal requirements. The over-all accuracy of the termination is about 0.1 percent, the resistances used

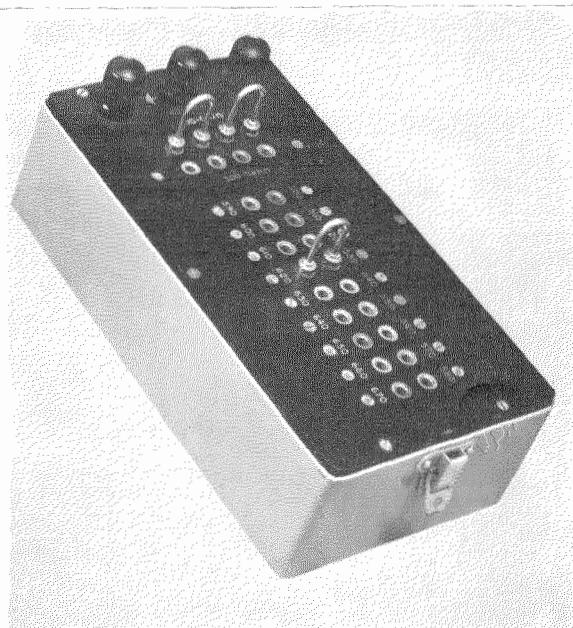

having a very low phase angle, while the symmetrical arrangement of the resistances and internal wiring ensures a high degree of balance to earth.

Selection of the particular termination value required is effected by means of a simple system of U links and sockets, the arrangement of which is clearly shown in the illustration. The pair of U links at the left-hand end of the panel occupies one of two positions, the right-hand position covering the range 500 to 580 ohms and the left-hand position the range 590 to 670 ohms. The particular value of impedance in the selected range is then determined by the position of the single U link in the row of sockets running down the centre of the panel. Each pair of these sockets has two values of impedance engraved beside it, a red figure applying to the 500-580-ohm range of values and a white figure to the 590-to-670-ohm range.

This simple and symmetrical arrangement of U links and sockets has the advantage that a clear visual indication of the setting of the box is obtained, thus minimizing the possibility of errors. This is of particular importance where the unit is under control of an assistant at the far end of a line under test. Furthermore, high-resistance-contact troubles are unlikely to occur as the U links and sockets are easily accessible for cleaning.

The terminating unit is housed in a steel box and has a phenol-fibre panel fitted with a brass screening plate: the resistances and internal wiring are thus effectively shielded. The box is of a convenient size for placing on the cross-arm of a pole during tests and measures approximately $8\frac{1}{2}$ by $4\frac{1}{2}$ by $3\frac{3}{4}$ inches high with the lid in position. The unit is known as the SPS 115 Termination Box and replaces one

coded 74103-A which employs switches for selecting the termination values.

• • •

COMPañIA TELEFÓNICA NACIONAL DE ESPAÑA —International Telephone and Telegraph Corporation has concluded an agreement with the Compañía Telefónica Nacional de España, effective January 1, 1946, whereby I.T.&T. will act as technical consultant and advisor to C.T.N.E. in connection with the maintenance, operation, and future development of the telephone system of Spain. This follows the sale, last year, of the interests of I.T.&T. in the Spanish Telephone Company after twenty years of control during which I.T.&T. built a modern telephone system in Spain.¹

I.T.&T. agrees to furnish to the Spanish Telephone Company, in addition to technical advice and services, instructions on engineering, building and maintenance, traffic, business practices and accounting, construction methods, and material specifications. It will keep a small staff in Spain to maintain the necessary contact with the C.T.N.E.

A second contract covers the continued supply of equipment by Standard Electrica, S.A., manufacturing subsidiary of I.T.&T. in Spain, to the Spanish Telephone Company. Standard Electrica, S.A. has factories in Madrid and Maliano (Santander) and supplied the bulk of the cable and equipment required in the expansion and rehabilitation of the Spanish telephone system during the past two decades.

Each of these two contracts runs for five years and indefinitely thereafter until cancelled by either party.

¹O. C. Bagwell and J. J. Parson, "Twenty Years of Telephony in Spain," *Electrical Communication*, v. 22, n. 4, pp. 314-321; 1945.

Contributors to This Issue

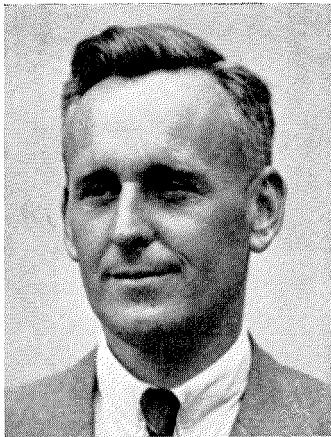

D. A. ALBERTS

D. A. Alberts was born on November 16, 1908 in Steelton, Pennsylvania, U. S. A. He received a degree in electrical engineering from the University of Delft in 1932, and continued for a year as an assistant in the telecommunication laboratory of the university.

During 1933 and 1934, he served as an engineer in the Siemens & Halske Works in The Hague. In 1934, he joined the staff of the Dutch Administration of Posts, Telegraphs, and Telephones and at present is in charge of the maintenance and circuit department.

• • •



W. A. BRANDT

W. A. Brandt received the degree of doctor of technical sciences from the Technical University, Vienna, Austria, in 1922.

On graduation, he joined the staff of the Austrian Telephone Manufacturing Company, which company became associated with the I. T. & T. System in 1930. Dr. Brandt was transferred to the United Telephone & Telegraph Works in Vienna until 1938 when he went to the Bell Telephone Manufacturing Company in Antwerp, Belgium, for two years.

From 1941 to 1943, Dr. Brandt was engaged in development work for the U. S. Army and the Columbia Broadcasting System in New York City. He has been with Federal Telephone and Radio Corporation since 1943 and has been concerned chiefly with carrier systems and automatic switching methods.

• • •

R. A. L. Cole served in the Royal Engineers Signals from 1917 to 1919. In 1922, he graduated with honours in mathematics and natural sciences at Cambridge University.

He then joined the engineering staff of the International Western Electric Company, which subsequently became Standard Telephones and Cables, receiving further specialized training at the Bell Telephone Laboratories (New York) and the Western Electric Hawthorne plant (Chicago). He worked on transmission, cable, and loading-coil development until 1931. During this period he assisted in the protection of the Simplon Tunnel telephone cable against induced noise from the railway traction system and carried out similar work on a railway cable in Sweden. He supervised the manufacture of toll cables at a number of associate factories in Austria, Czechoslovakia, and Hungary. On the formation of the Hendon Laboratories he led a mathematical group which investigated the fundamental transmission problems involved in transatlantic submarine-cable telephony.

In 1931 he transferred to the valve division where he developed manufacturing methods which greatly increased



R. A. L. COLE

the life and reliability of hydrogen-filled ballast lamps. He worked on the development of microwave tubes for the 18-centimeter cross-channel link and on the first introduction in England of the thoriated-tungsten filament. He has developed X-ray and other high-voltage tubes and equipment. At present he is engaged on general physical problems associated with valve manufacture.

• • •

Sidney Frankel was born on October 6, 1910 in New York City. Rensselaer Polytechnic Institute conferred three degrees on him: the B.A. degree in electrical engineering in 1931, and in mathematics the M.A. degree in 1934

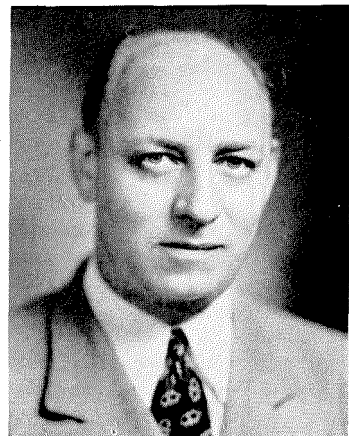

SIDNEY FRANKEL



JOHN J. GLAUBER

and the Ph.D. degree in 1936. He was an instructor in mathematics from 1931 to 1933.

For a year after leaving college, Dr. Frankel served as a sound-recording engineer with the Brooklyn Vitaphone Corporation. In 1937-1938, he was an assistant engineer in the design and development of electronic flight instruments for the Eclipse Aviation Corporation.

He joined the Federal Telegraph Company staff at Newark, New Jersey, in 1938 as an engineer on the design and development of radio transmitters. In 1943, he was transferred to Federal Telephone and Radio Laboratories, now Federal Telecommunication Laboratories. At present he is engaged in the development of components for microwave systems.

He is a member of Sigma Xi and an Associate member of the Institute of Radio Engineers.

• • •

John J. Glauber was born in New York, New York, on July 31, 1903. He received the M.E. degree from Stevens Institute of Technology in 1925.

In 1925, he obtained a position with the U. S. Tool Company in Ampere, New Jersey, on variable-capacitor design. In 1927, he joined the Arcturus Radio Tube Company, Newark, New Jersey, as laboratory assistant and was chief engineer from 1933 to 1936. He then joined the Westinghouse Lamp Company, Bloomfield, New Jersey, as a vacuum tube development engineer and in 1939 became development engineer for the National Union Radio

Corporation, Newark, N. J. He was employed by the Clark Controller Company, Cleveland, Ohio as development engineer on special gas-filled control tubes, and by the Champion Radio Works, Danvers, Massachusetts, as quality engineer.

He joined the vacuum tube department of Federal Telecommunication Laboratories, New York, in 1941, as engineer and is now department head in charge of the design and development of tubes.

Mr. Glauber is a Senior Member of the Institute of Radio Engineers.

• • •

William Hatton entered the employ of the International Western Electric Company in 1919. One of his first assignments was an early installation of a rotary telephone exchange in Bergen, Norway. From 1922 to 1926, he was in the engineering department of the Bell Telephone Manufacturing Company in Antwerp, Belgium. He was then placed in charge of the design and development of telephone switching systems in the development laboratories of the I.T. & T. in Paris.

In 1934, Mr. Hatton returned to Antwerp as technical director in charge of all development and engineering work. With the invasion of Belgium in 1940, he came to I.T. & T. headquarters in New York, New York, and played an important role in the development of Federal Telephone and Radio Corporation. He was named deputy chief engineer of I.T. & T. in 1944 and is also vice president of the International Standard Electric Corporation.



WILLIAM HATTON

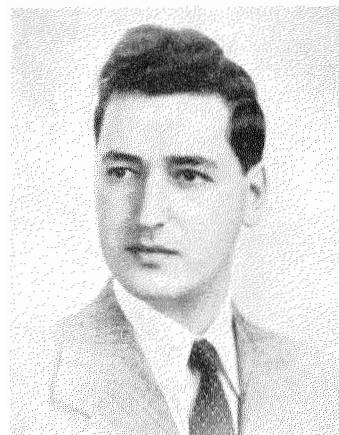

LESTER L. LIBBY

In the course of his services in the I.T. & T. System, Mr. Hatton has traveled extensively throughout the world. He has also been instrumental in the installation of telephone systems in New Zealand, Australia, Java, Egypt, Argentina, Brazil, and Peru.

More than 70 patent applications carry his name and concern such important developments as automatic ticketing, electric calculators, unattended rural and small-town exchanges, and varied forms of long-distance signalling.

• • •

Lester L. Libby was born at Hartford, Connecticut, on January 26, 1914. He received the B.S. and M.S. degree in electrical engineering from the Worcester Polytechnic Institute in 1935 and 1936, respectively. During the summers of 1934 and 1935 he served as radio transmitter operator and as assistant to the chief engineer of WTAG, Worcester, Massachusetts.

From 1936 to 1938, he was employed as a radio-tube design engineer for RCA Radiotron, and from 1938 to 1941 he served in the radio receiving-tube division of Tung-Sol Lamp Works in a similar capacity.

He entered the radio receiver laboratory of the Federal Telegraph Company in 1941. He was project engineer in the direction-finder division from 1942 to 1944, then transferred to the laboratories division in the capacity of senior engineer, developing direction-finding receivers, antenna systems, and cathode-ray indicators. He is now a section head in Federal Telecommuni-



A. J. MADDOCK

ation Laboratories, being in charge of development of microwave radio-link equipment for pulse-time-modulation multiplex systems.

Mr. Libby is a member of Sigma Xi and a Senior Member of the Institute of Radio Engineers.

• • •

A. J. Maddock was born at Hough Green, Lancashire, England, on February 27, 1906. He received the degree of Hons. B.Sc. in 1927 and M.Sc. in 1928 from Liverpool University.

He was first employed by the British Thomson Houston Company, Ltd. in 1928 at Rugby on thermionics and radio valves. In 1930, he joined the staff of Thermal Syndicate Ltd., Wallsend-on-Tyne, to do research on gas discharges and applied optics.

He became associated with Standard Telephones & Cables in 1935. Initially he was engaged in design and develop-

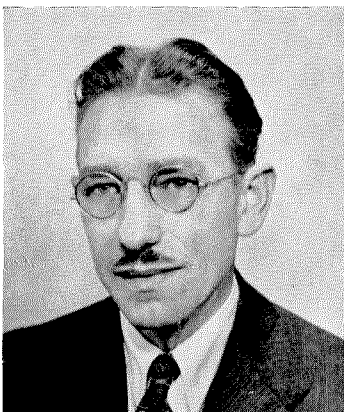

R. G. MADDOX

ment of high-power radio transmitters, and is now in charge of industrial electronics, particularly high-frequency heating.

Mr. Maddock is a Fellow of the Institute of Physics, a member of its Board, and Honorary Secretary of its Electronics Group. He is a Member of the Institution of Electrical Engineers.

• • •

R. G. Maddox attended Gustafus Adolphus College from 1921 to 1923. He then became a radio aide for the U. S. Navy and installed arc transmitters on vessels of the Asiatic Fleet. He returned to the U.S.A. in 1925 to become a field engineer in the RCA Radiola Division. From 1926 to 1929, he owned and operated broadcast station KFWH.

In 1930, he joined the Telephone Equipment and Engineering Company of San Francisco where he worked on ship communication systems and mine telephones. He was engaged also with ship-to-shore radio and commercial sound equipment problems. He became a member of the Signal Corps General Development Laboratories at Fort Monmouth, New Jersey, in 1941. Until 1944, he was developing carrier and multichannel radio relay systems.

Mr. Maddox has been working on carrier and systems developments for Federal Telephone and Radio Corporation since 1944.

• • •

Jean Jacques Muller was born at Bale, Switzerland, on September 6, 1910. After his studies at the Ecole Centrale des Arts et Manufactures of Paris, which he left in 1934, he obtained the diploma of Doctor in technical sciences at the Federal Polytechnical School at Zurich. From 1935 till 1940, he was engaged in important research and development work on decimetric waves and television at the Federal Polytechnical School at Zurich.

In 1940, he entered Les Laboratoires, Le Matériel Téléphonique, Paris, where he contributed first to the study of microwave installations and was later put in charge of the division for the design and construction of radio transmitters.

• • •

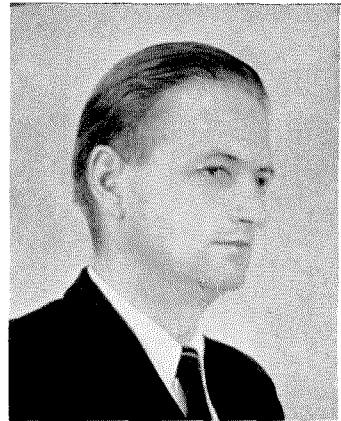

J. J. MULLER

A. C. Phillips received the B.A. degree from Houghton College in 1942. For the next two years, she was in the U. S. Signal Corps General Development Laboratories at Fort Monmouth, New Jersey.

Since 1944, Miss Phillips has been associated with Federal Telephone and Radio Corporation on carrier development work.

• • •

J. P. Verlooy was born in Rotterdam, The Netherlands, on July 2, 1890. He received a degree in electrical engineering from the University of Delft in 1914.

On graduation, he became an assistant engineer in The Netherlands Patent Office. In 1917, he joined the installation department of the Bell Telephone

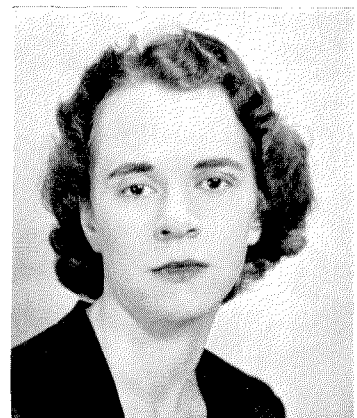

A. C. PHILLIPS



J. P. VERLOOY

Manufacturing Company of Antwerp, and in 1921 was transferred to the engineering department where he was concerned mainly with the technical and economic problems of automatic switching systems.

From 1929 to 1934, Mr. Verlooy was in Milan, Italy, working on the engineering problems of the automatization of the Italian telephone network. In 1934, he became manager of The Hague office.

• • •

Karl H. Zimmermann was born in Woodside, New York, on January 17, 1911. He received the degree of B.S. in electrical engineering in 1934 from New York University. He holds a professional engineer license granted by the State of New York.

From 1934 to 1937, he served as a construction engineer for the Elite Electric Company of Forest Hills, New York, and for the next five years was with Habirshaw Cable and Wire Corporation in Yonkers, New York, where he was engaged in research, development, and design of communication and power cable.

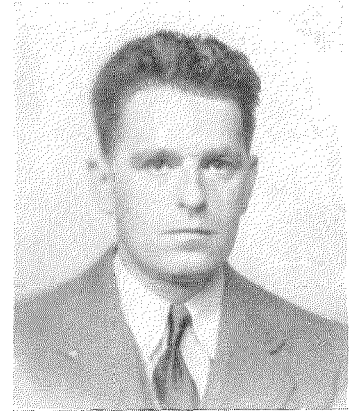

KARL H. ZIMMERMANN

In 1942, Mr. Zimmermann joined the Intelin Division of Federal Telephone and Radio Corporation at Newark, New Jersey. His present duties concern problems relating to the design, manufacture, and sale of power, communication, and high-frequency cables.

INTERNATIONAL TELEPHONE AND TELEGRAPH CORPORATION

Associate Manufacturing and Sales Companies

UNITED STATES OF AMERICA

INTERNATIONAL STANDARD ELECTRIC CORPORATION, New York, New York

FEDERAL TELEPHONE AND RADIO CORPORATION, Newark, New Jersey

GREAT BRITAIN AND DOMINIONS

STANDARD TELEPHONES AND CABLES, LIMITED, London, England

Branch Offices: Birmingham, Leeds, Manchester, England; Glasgow, Scotland; Dublin, Ireland; Cairo, Egypt; Calcutta, India; Johannesburg, South Africa.

CRED AND COMPANY, LIMITED, Croydon, England

INTERNATIONAL MARINE RADIO COMPANY LIMITED, Liverpool, England

KOLSTER-BRANDS LIMITED, Sidcup, England

STANDARD TELEPHONES AND CABLES PTY. LIMITED, Sydney, Australia

Branch Offices: Melbourne, Australia; Wellington, New Zealand.

NEW ZEALAND ELECTRIC TOTALISATORS LIMITED, Wellington, New Zealand

FEDERAL ELECTRIC MANUFACTURING COMPANY, LTD., Montreal, Canada

SOUTH AMERICA

COMPAÑIA STANDARD ELECTRIC ARGENTINA, SOCIEDAD ANÓNIMA, INDUSTRIAL Y COMERCIAL, Buenos Aires, Argentina

STANDARD ELECTRICA, S.A., Rio de Janeiro, Brazil

COMPAÑIA STANDARD ELECTRIC, S.A.C., Santiago, Chile

EUROPE AND FAR EAST

VEREINIGTE TELEFON- UND TELEGRAFEN-WERKE AKTIENGESELLSCHAFT, Vienna, Austria

BELL TELEPHONE MANUFACTURING COMPANY, Antwerp, Belgium

CHINA ELECTRIC COMPANY, LIMITED, Shanghai, China

STANDARD ELECTRIC DOMS A SPOLECNOST, Prague, Czechoslovakia

STANDARD ELECTRIC AKTIESELSKAB, Copenhagen, Denmark

COMPAGNIE GÉNÉRALE DE CONSTRUCTIONS TÉLÉPHONIQUES, Paris, France

LE MATÉRIEL TÉLÉPHONIQUE, Paris, France

LES TÉLÉIMPRIMEURS, Paris, France

LIGNES TÉLÉGRAPHIQUES ET TÉLÉPHONIQUES, Paris, France

FERDINAND SCHUCHHARDT BERLINER FERNSPRECH- UND TELEGRAPHENWERK AKTIENGESELLSCHAFT, Berlin, Germany

LORENZ, C., A.G. AND SUBSIDIARIES, Berlin, Germany

MIX & GENEST AKTIENGESELLSCHAFT AND SUBSIDIARIES, Berlin, Germany

SÜDDEUTSCHE APPARATEFABRIK GESELLSCHAFT M.B.H., Nuremberg, Germany

TELEFONFABRIK BERLINER A.G. AND SUBSIDIARIES, Berlin, Germany

NEDERLANDSCHE STANDARD ELECTRIC MAATSCHAPPIJ N.V., Hague, Holland

DIAL TELEFONKERESKEDELMI RÉSZVÉNY TÁRSASÁG, Budapest, Hungary

STANDARD VILLAMOSSÁGI RÉSZVÉNY TÁRSASÁG, Budapest, Hungary

TELEFONGYÁR R.T., Budapest, Hungary

FABBRICA APPARECCHIATURE PER COMUNICAZIONI ELETTRICHE, Milan, Italy

SOCIETA FINANZIARIA ELETTROTELEFONICA, Milan, Italy

SOCIETA ITALIANA RETI TELEFONICHE INTERURBANE, Milan, Italy

NIPPON ELECTRIC COMPANY, LIMITED, Tokyo, Japan

SUMITOMO ELECTRIC INDUSTRIES, LIMITED, Osaka, Japan

STANDARD TELEFON- OG KABELFABRIK A/S, Oslo, Norway

STANDARD ELECTRIC COMPANY W. POLSCE SP. Z.O.O., Warsaw, Poland

STANDARD ELECTRICA, Lisbon, Portugal

STANDARD FABRICA DE TELEFOANE SI RADIO S.A., Bucharest, Rumania

COMPAÑIA RADIO AEREA MARITIMA ESPAÑOLA, Madrid, Spain

STANDARD ELÉCTRICA, S.A., Madrid, Spain

AKTIEBOLAGET STANDARD RADIOFABRIK, Stockholm, Sweden

STANDARD TELEPHONE ET RADIO S.A., Zurich, Switzerland

JUGOSLAVENSKO STANDARD ELECTRIC COMPANY AKCIONARNO DRUSTVO, Belgrade, Yugoslavia

TELEOPTIK A.D., Belgrade, Yugoslavia

Telephone Operating Systems

UNITED RIVER PLATE TELEPHONE COMPANY, LIMITED, Buenos Aires, Argentina

COMPAÑIA TELEFÓNICA ARGENTINA, Buenos Aires, Argentina

COMPAÑIA TELEGRÁFICO-TELEFÓNICA COMERCIAL, Buenos Aires, Argentina

COMPAÑIA TELEGRÁFICO-TELEFÓNICA DEL PLATA, Buenos Aires, Argentina

COMPANHIA TELEFONICA PARANAENSE S.A., Curitiba, Brazil

COMPANHIA TELEFONICA RIO GRANDENSE, Porto Alegre, Brazil

COMPAÑIA DE TELÉFONOS DE CHILE, Santiago, Chile

CUBAN TELEPHONE COMPANY, Havana, Cuba

MEXICAN TELEPHONE AND TELEGRAPH COMPANY, Mexico City, Mexico

COMPANHIA PERUANA DE TELÉFONOS LIMITADA, Lima, Peru

PORTO RICO TELEPHONE COMPANY, San Juan, Puerto Rico

SHANGHAI TELEPHONE COMPANY, FEDERAL, INC., U.S.A., Shanghai, China

Radiotelephone and Radiotelegraph Operating Companies

COMPAÑIA INTERNACIONAL DE RADIO, Buenos Aires, Argentina

COMPAÑIA INTERNACIONAL DE RADIO BOLIVIANA, La Paz, Bolivia

COMPANHIA RADIO INTERNACIONAL DO BRASIL, Rio de Janeiro, Brazil

COMPAÑIA INTERNACIONAL DE RADIO, S.A., Santiago, Chile

RADIO CORPORATION OF CUBA, Havana, Cuba

RADIO CORPORATION OF PORTO RICO, San Juan, Puerto Rico†

† Radiotelephone and Radio Broadcasting services.

Cable and Radio Telegraph Operating Companies

(Controlled by American Cable & Radio Corporation)

THE COMMERCIAL CABLE COMPANY, New York, New York¹

MACKAY RADIO AND TELEGRAPH COMPANY, New York, New York²

ALL AMERICA CABLES AND RADIO, INC., New York, New York³

THE CUBAN ALL AMERICA CABLES, INCORPORATED, Havana, Cuba¹

SOCIEDAD ANÓNIMA RADIO ARGENTINA, Buenos Aires, Argentina⁴

¹ Cable service. ² International and Marine Radiotelegraph services. ³ Cable and Radiotelegraph services. ⁴ Radiotelegraph service.

Laboratories

INTERNATIONAL TELECOMMUNICATION LABORATORIES, INC., New York, New York

FEDERAL TELECOMMUNICATION LABORATORIES, INC., New York, New York

STANDARD TELECOMMUNICATION LABORATORIES LTD., London, England

LABORATOIRE CENTRAL DE TÉLÉCOMMUNICATIONS, Paris, France